



CSD 3 Sunshine Duration Sensor

FOR THE PRECISE MEASUREMENT OF SUNSHINE DURATION

- No moving parts
- Low maintenance at long intervals
- Low power consumption
- Suitable for remote stations
- Rugged and durable

INTRODUCTION

Sunshine duration is defined by World Meteorological Organisation (WMO) as the time during which the direct solar radiation exceeds the level of 120 W/m^2 , and is normally measured in hours.

Traditionally, sunshine duration is monitored using a Campbell-Stokes recorder, where a glass sphere focuses the sun onto a marked card and burns it when it is sunny. However, the burn marks vary depending upon the material and dampness of the card (high humidity or after rain). The card must be changed every day, the marks must be analysed manually, and the results are highly subjective.

Meteorological agencies want to automate this process and reduce the variability of results. A very accurate solution is to use a sun tracker and a pyrheliometer, but this is relatively expensive. Therefore, Kipp & Zonen designed the CSD 3 Sunshine Duration Sensor. It is engineered for continuous outdoor use and is easy to install and service. It is used by major national weather networks across Europe, and elsewhere.

APPLICATIONS

Sunshine Duration Sensors are widely used in weather networks and holiday resorts to provide the number of sunshine hours per day for tourist information. In health spas and clinics they contribute to the measurements used in treatment and recovery. In agronomy the amount of sunshine received by crops can be used to help forecast yields. In building automation the CSD 3 can be used as an input to the systems for the control of the internal environment, such as the deployment of sun blinds.

The Kipp & Zonen CSD 3 Sunshine Duration Sensor is rugged and durable and can be used at all latitudes.

CSD 3 SUNSHINE DURATION SENSOR

CSD 3 measures solar radiation through a high quality glass tube. It has no moving parts and uses 3 photo-diodes with specially designed diffusers to make an analogue calculation of when it is sunny. The output is switched high or low to indicate sunny or not sunny conditions. The calculated direct irradiance value is also available.

The waterproof plug-and-socket cable connection enables easy installation and servicing. The standard cable is 15 m long, 25 m is an option. The large drying cartridge with screw-on cap gives extended change intervals, and a humidity indicator shows clearly when this is necessary.

CSD 3 operates from 12 VDC power and has two levels of built-in heating to dissipate rain, snow and frost. These are normally switched externally, but an optional internal thermostat control is available. A robust mounting arm is fitted to the base of the instrument.

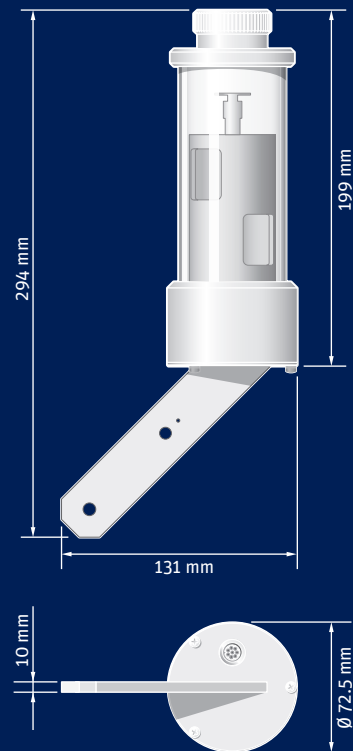

Specifications	CSD 3
Spectral range	400 to 1100 nm
Operating temperature	-40 °C to +70 °C
Sunshine signal	1 ±0.1 V (direct radiation > 120 W/m ²)
Accuracy	> 90% (monthly sunshine hours)
Analogue output signal	1 mV/Wm ² (direct solar radiation)
Accuracy	> 90% (direct signal for clear sky)
Non-stability	< 2 % change per year
Temperature dependence	< 0.1 %/°C
Response time	< 1 ms
Power supply	< 0.1 W at 12 VDC (9-15 VDC)
Heating level 1	1 ±0.1 W at 12 VDC (dew removal)
Heating level 2	10 ±1 W at 12 VDC (frost and snow removal)
Thermal switch (optional)	Level 2 ON < 6 °C ±3 °C Level 2 OFF > 14 °C ±3 °C

Note: The performance specifications quoted are worst-case and/or maximum values



Go to your local distributor



For pricing information, please contact Omni Instruments Ltd

Unit 1, 14 Nobel Road,
Wester Gourdie Industrial Estate,
Dundee, DD2 4UH.

Email: info@omni.uk.com
Tel: +44 (0) 1382 443000