

Senturion XPR02 Proximity Probe



- Switch selectable system cable lengths 5m, 7m and 9m.
- 5mm tip diameter for tight installation applications.
- LED indication of selected length.
- 3.5mm socket for gap voltage monitoring.
- Double screened cable for high noise immunity.
- Snap lock and shake proof cable connection.
- Excellent repeatability on replacement of probe, extension or driver.
- Compliant with standard API 670.

The XPR02 proximity probe system is made up of a calibrated probe, extension cable and driver, providing a 5mm tip diameter for tight installation applications. Utilising the eddy current principle, this combination forms a tuned circuit with the target material and variations in probe face to target distance are detected in this circuit by the driver. This provides a linearised voltage output proportional to target gap with a nominal sensitivity of 7.87 mV/ μ m and a range of up to 2.5 mm. This type of measurement system provides highly accurate (resolution typically less than one micro-meter) vibration and relative positional measurements, for harsh environments up to 180 °C.

The driver unit offers selectable system lengths of 5 m, 7 m or 9 m, with a front panel green LED indicating the selected option. The gap voltage monitoring socket assists with commissioning the probe system; a volt meter can be connected directly to the driver through the 3.5 mm standard audio socket to display the gap voltage at the point of installation and the probe mechanical gap can then be adjusted to suite the application.

The cable system incorporates snap lock connectors which require no torquing and provide a shake proof solution important for heavy industrial applications. The double screened cable offers robustness in combination with high immunity to interference and optional stainless steel convoluted armour is available for applications or environments where cable protection is paramount.

For pricing or any further information, please contact Omni Instruments Ltd.

System Performance

Measurement Range: 0.0 mm to 2.5 mm

Linearity: $\pm 1\%$, -1.0 V to -19.0 V (% of FS) $\pm 2\%$, 0 °C to +150 °C @ -10.0V

Std Sensitivity: 7.87 V/mm (200 mV/mil) $\pm 1\%$

Resolution: <0.001 mm

Interchangability: Maximum interchangability error replacing either probe, extension cable or driver in calibrated system is $\pm 5\%$.

Available system lengths: 5 m, 7 m and 9 m

Cable length tolerance

Probe (1 metre): 1.0 m to 1.5 m

Cable Extension (4 metre): 4.0 m to 4.4 m

Cable Extension (6 metre): 6.0 m to 6.6 m

Cable Extension (8 metre): 8.0 m to 8.8 m

Frequency Response: DC to 10 kHz

Maximum Cable Length: 330 m based on 120 pF/m at <10 kHz and 500 um pk-pk. 3000 m based on 120 pF/m at <1 kHz and 500 um pk-pk.

Reference Target Material: ANSI 4140

Hazardous Area Approvals – ATEX / IECEx:

Driver	Probe
Ex II 1 GD	Ex II 1 GD
Ex ia IIC T4 Ga	Ex ia IIC T4/T2 Ga
Ex ia IIIC T135°C Da	Ex ia IIIC T135°C/ T300°C Da
-40°C ≤ Ta ≤ +80°C	-40°C ≤ Ta ≤ +80°C / +180°C

Probe

Probe tip diameter: 5.0 mm

Probe tip material: PPS 40 % Glass Filled

Probe body material: Stainless steel

Available probe body lengths: 20 mm to 250 mm
0.8 in to 9.6 in

Cable type: Triaxial 75 Ohm Coaxial, FEP outer jacket 3.2 mm outer diameter

Armoured option: Convoluted Stainless Steel 6.4 mm outer diameter

Probe Resistance: 3.1 Ohms ± 0.2 Ohm

Operating Temp Range: -40 °C to +180 °C

Storage Temp Range: -40 °C to +180 °C

Minimum target diameter: 10 mm

Effect of target curvature: +2 % for shaft diameter 150 mm
+5 % for shaft diameter 25 mm

Magnetic field effect: <1 % at 110 mT

Connector: Female Miniature Coaxial

Features: Suitable for tight installation applications where standard 8mm tip probe is too large.

Driver

Linear voltage range: -1.0 V to -19.0 V for 0.254 mm Standard Option (10 mil) to 2.54 mm (100 mil)

Linear voltage range: -1.0 V to -16.0 V for 0.254 mm Half Sensitivity Option (10 mil) to 4.064 mm (160 mil)

System length selection: Internal switch 5 m, 7 m or 9 m

System length indication: Green LED lamp

Power supply range: -16.0 Vdc to -28.0 Vdc
Note: Output voltage is limited to 1.2 V below supply voltage when supply is < -21.5 V.

Power supply: < 0.3 mVout / Vsupply sensitivity

Power consumption: 3 mA typ, 7 mA max

Output impedance: 75 Ohms

Monitor Output Impedance: 10 KOhm

Sensor Connector type: Self Locking Miniature Male Coaxial

Monitor Connector type: 3.5 mm audio jack

Mounting: Din Rail or Plate

Mass: 250 grams

Operating Temp Range: -40 °C to +90 °C

Storage Temp Range: -40 °C to +90 °C

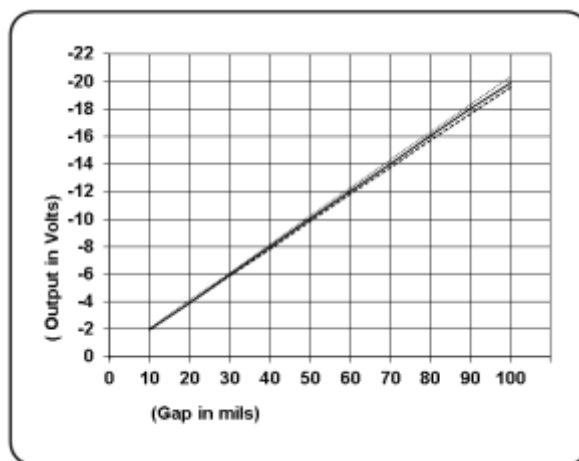

Typical 5m system performance
 ————— 25 °C
 50 °C
 - - - - - 150 °C or 0 °C

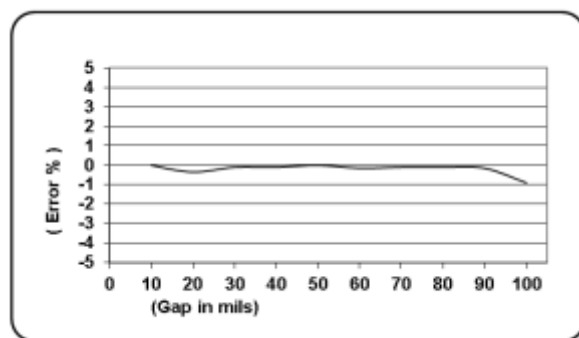

Typical 5m system performance

Probe Mechanical Configuration

Straight Mount M6 Case

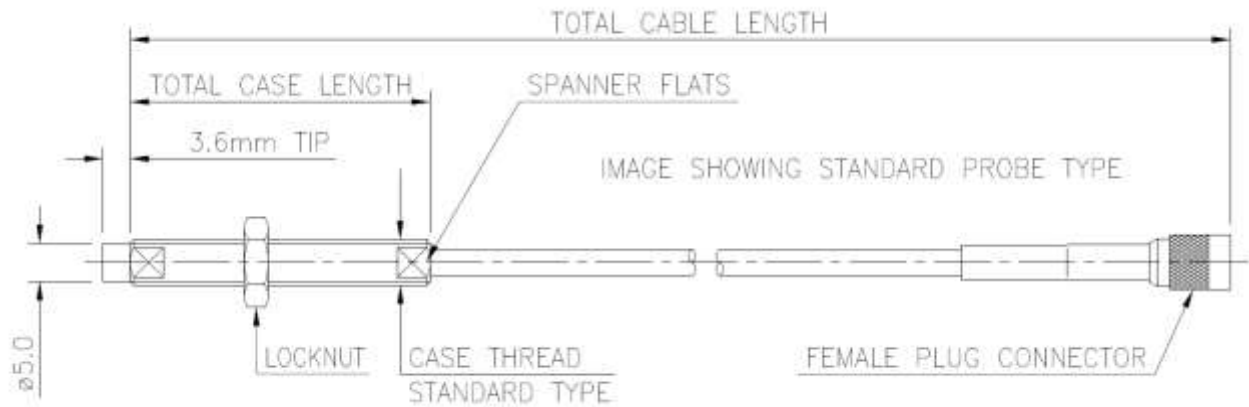

Straight Mount >M6 Case

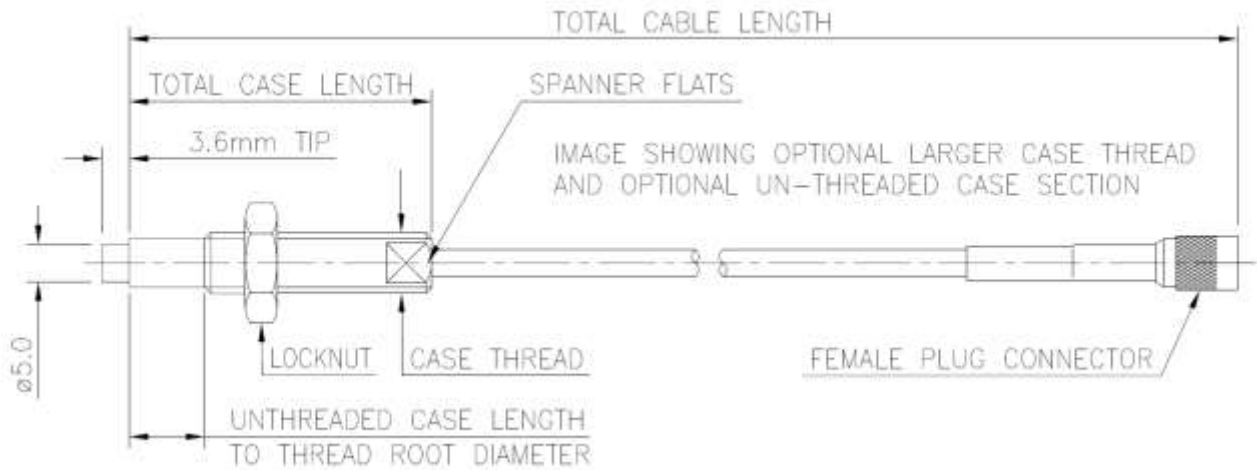

Extension Cable Mechanical Drawing

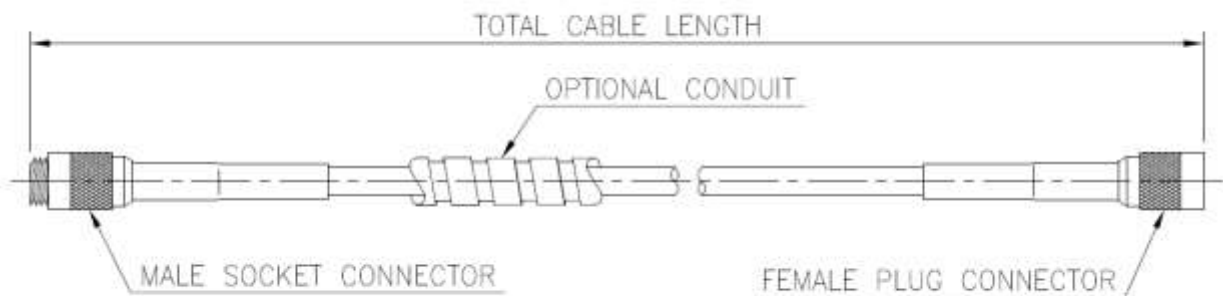

Driver Mechanical Configuration

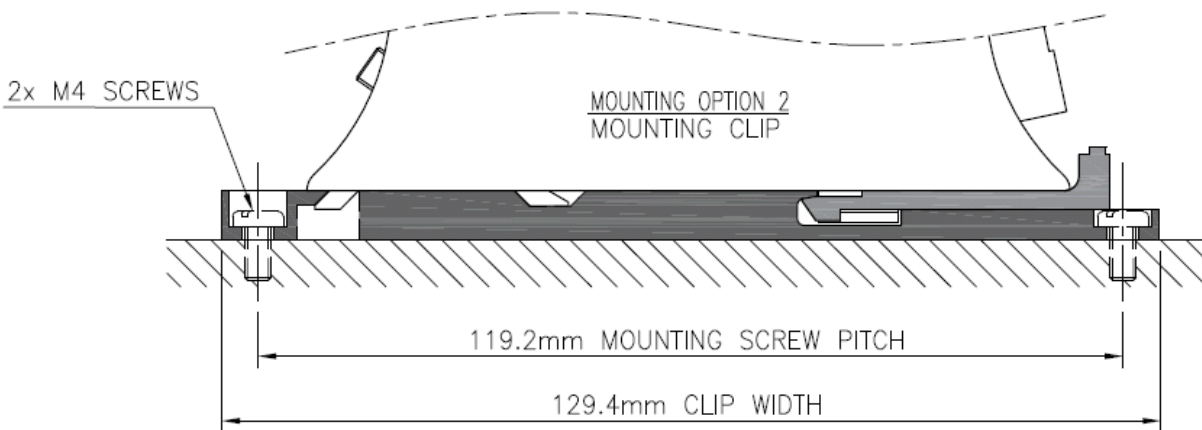
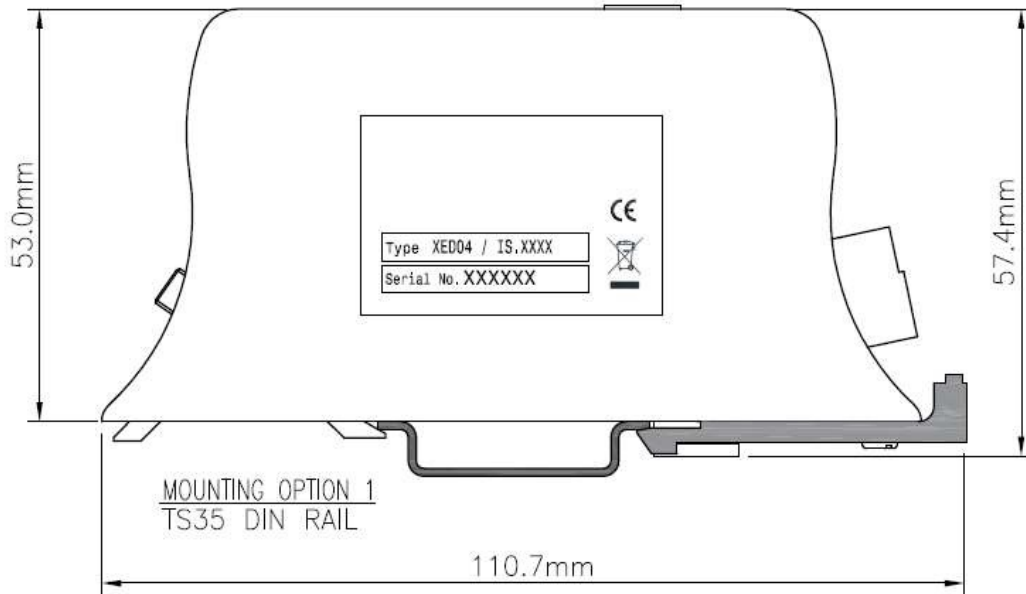
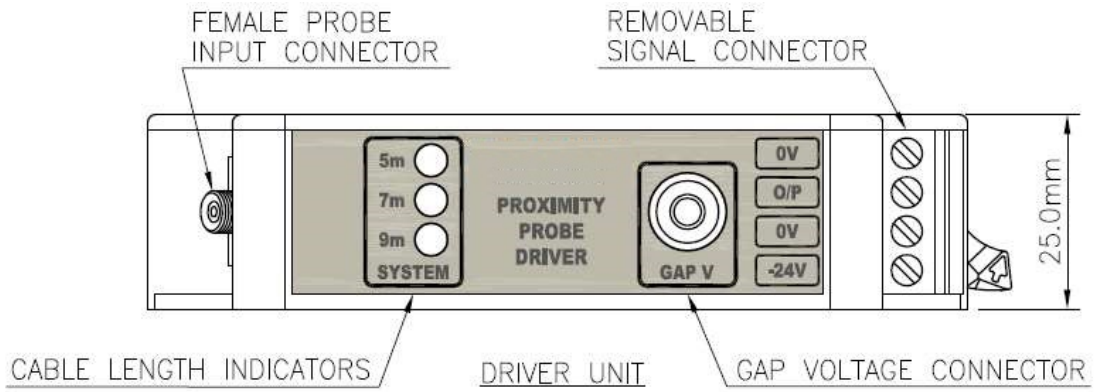

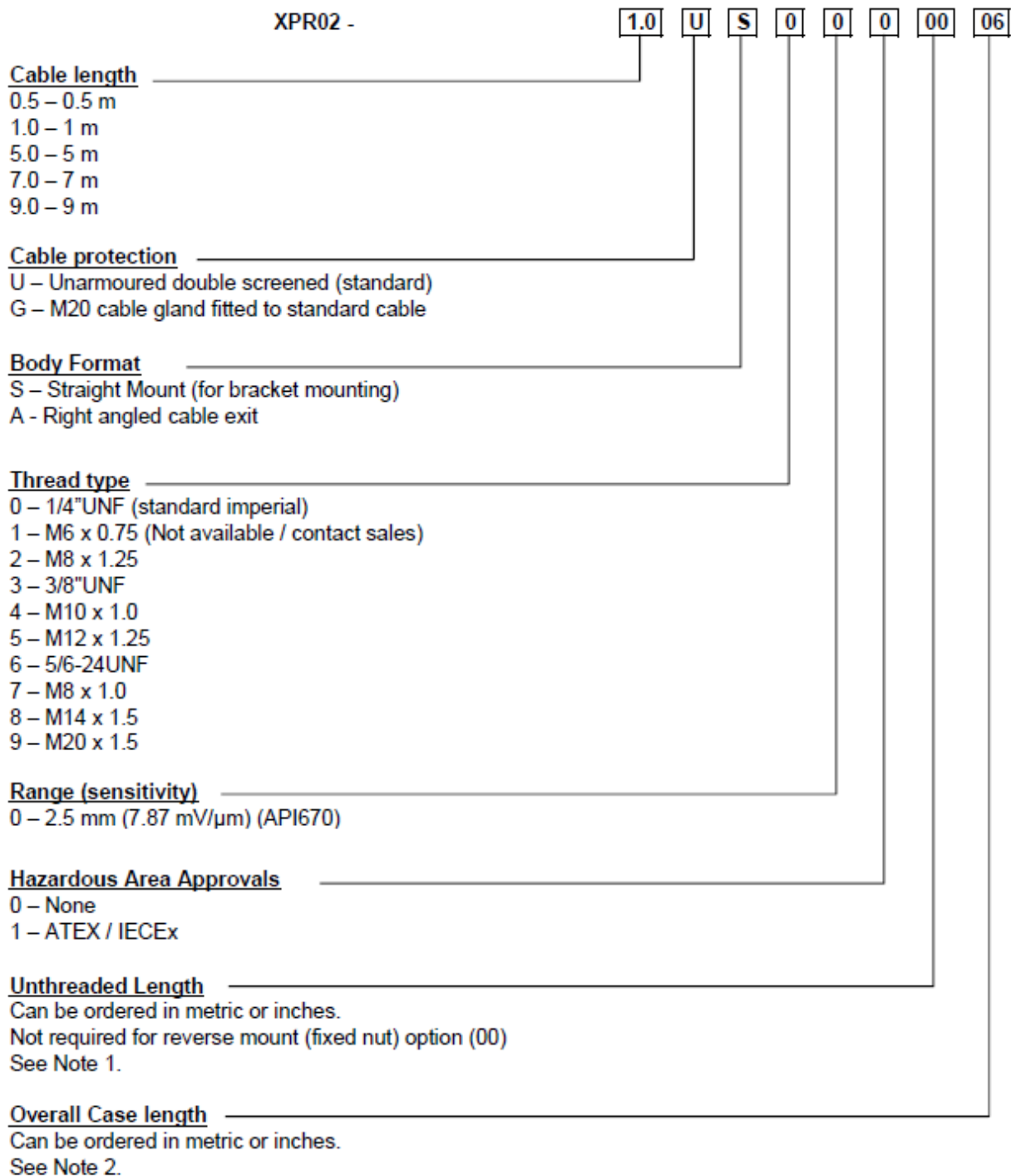
Probe Ordering Information**Note 1 - Unthreaded Length Option****Imperial Case**

Unthreaded length must be at least 0.8 inches less than the case length. Order in increments of 0.1 in.

Maximum unthreaded length: 8.8 in.

Minimum unthreaded length: 0.0 in.

Example: 04 = 0.4 in.

Metric Case

Unthreaded length must be at least 20 mm less than the case length. Order in increments of 10 mm.

Maximum unthreaded length: 230 mm.

Minimum unthreaded length: 0 mm.

Example: 06 = 60 mm.

Note 2 - Overall Case Length Option**Imperial Case**

Order in increments of 0.1 in.

Maximum case length: 9.6 in

Minimum case length: 0.8 in

Example: 24 = 2.4 in

Metric Case

Order in increments of 10 mm.

Maximum length: 250 mm.

Minimum length: 20 mm.

Example: 06 = 60 mm.

Driver Ordering Information

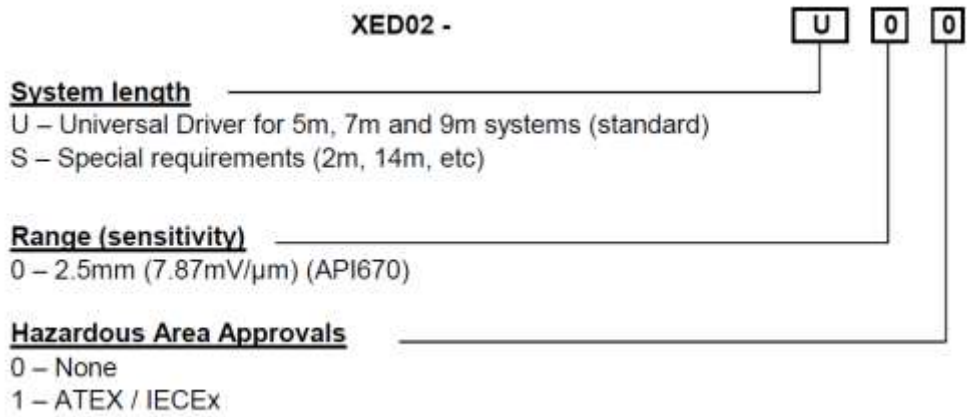

Extension Cable Ordering Information

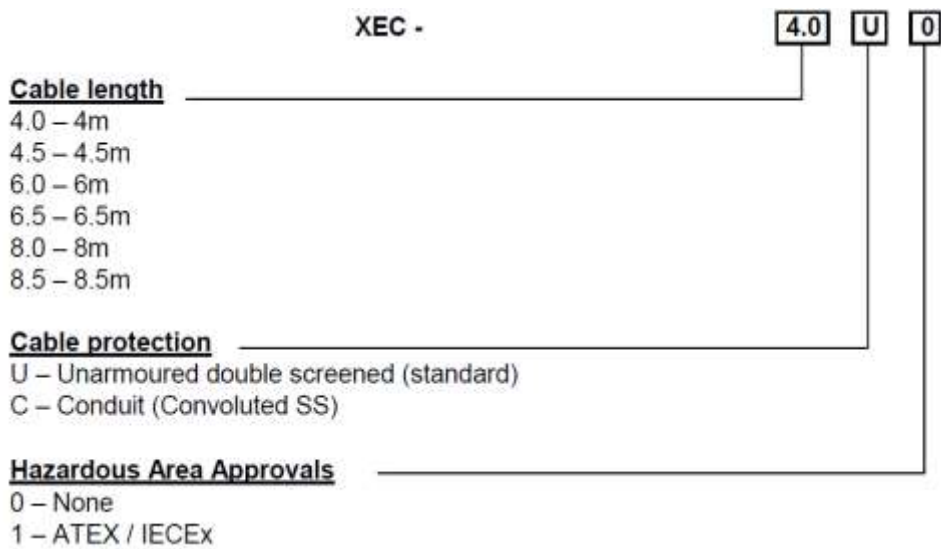

Whilst every effort has been made to ensure the accuracy of this specification, we cannot accept responsibility for damage, injury, loss or expense from errors or omissions. In the interest of technical improvement, this specification may be altered without notice.

For pricing or any further information, please contact Omni Instruments Ltd.



Contact Details:
Tel: +44 1382 443000
Email: info@omni.uk.com

Website: www.omniinstruments.co.uk

Mailing Address: Unit 1, 14 Nobel Road,
Wester Gourdie Industrial Estate,
Dundee, DD2 4UH.