

LEO5

High-resolution digital manometer

Features

- Insulated piezoresistive pressure sensor encapsulated in an oil-filled metal housing
- Robust, watertight stainless steel housing with safety glass front
- Large, backlit LC display
- Integrated rechargeable battery (USB chargeable)
- License-free KELLER software available to download

Functions

- High-resolution pressure measurements
- Pressure peak detection with 5 kHz sampling frequency
- Data logger
- Operated via capacitive touch keys
- Bar graph display
- Temperature display
- Min/max display

Typical Applications

- Pressure testing
- Calibration
- Laboratory use
- Industrial applications



Accuracy

± 0,05 %FS

Total Error Band

± 0,1 %FS

Pressure Ranges

-1...3 bar to 0...1000 bar

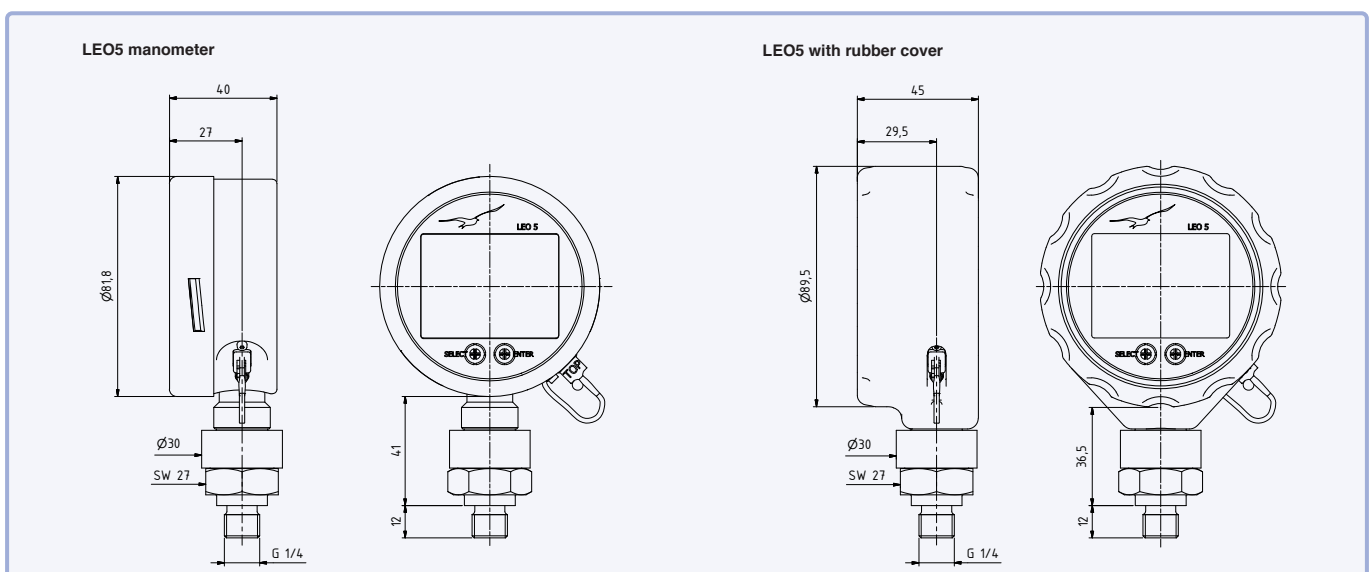

For pricing or any further information, please contact Omni Instruments Ltd.

LEO5 – Specifications

Standard Pressure Ranges

Gauge pressure, PR	-1...1	-1...3	-1...6	-1...10	-1...16	-1...30									bar rel.
Absolute pressure, PAA	0...2	0...4	0...7	0...11	0...17	0...31	0...61	0...101	0...161						bar abs.
Absolute pressure, PA										0...300	0...400	0...700	0...1000	bar	
Overload resistance	8	8	20	20	40	60	200	200	300	600	800	1100	1100	bar	
Display resolution	0,0001	0,0001	0,001	0,001	0,001	0,001	0,001	0,01	0,01	0,01	0,01	0,02	0,05	0,1	bar

Key	PR	Gauge pressure	Zero at atmospheric pressure
	PAA	Absolute pressure	Zero at 0 bar abs. (vacuum)
	PA	Absolute pressure	Zero at 1 bar abs.

Performance

Accuracy @ RT (20...25 °C)	$\leq \pm 0,05$ %FS	Nonlinearity (BFSL), pressure hysteresis, non-repeatability, zero point, amplification
Total error band (0...50 °C)	$\leq \pm 0,1$ %FS	Max. deviation within the specified pressure and temperature range
Long-term stability	$\leq \pm 0,1$ %FS	Per year under reference conditions, yearly recalibration recommended
Degree of dependency on location	$\leq \pm 1,5$ mbar	Calibrated in vertical installation position with pressure connection facing downwards
Accuracy of temperature measurement	± 1 °C typ.	
Pressure range reserve	± 10 %	
Vacuum endurance	$\leq 0,2$ bar abs.	Of operation $\leq 0,2$ bar abs. upon request

Temperature Ranges

Compensated temperature range	0...50 °C
Media temperature	-10...60 °C
Ambient temperature	0...50 °C
Storage temperature	-20...70 °C

Electrical Data

Rechargeable battery	Lithium-ion 4,2 V / 2,3 Ah
Battery life (standard)	Up to 2000 hours of continuous operation
Battery life (peak mode)	Up to 160 hours of continuous operation
Battery charging cycles	> 300
GND case insulation	> 10 M Ω @ 300 VDC
External interface	USB (KELLER protocol)
Interface measuring rate	2 measurements per second
Electrical connection	Mini USB-B
CE conformity as per 2014/30/EU (EMC)	EN 61000-6-1 to -6-4, EN 61326-1 / EN 61326-2-3

Whilst every effort has been made to ensure the accuracy of this specification, we cannot accept responsibility for damage, injury, loss or expense from errors or omissions. In the interest of technical improvement, this specification may be altered without notice.

For pricing or any further information, please contact Omni Instruments Ltd.

LEO5 – Specifications

Electrical Data

Data logger

Logger function	Records pressure, temperature and measuring time
Data storage	≥ 56 000 measured values
Recording modes	Interval, event-controlled
Measuring rate	≥ 1 second, can be configured in 1-second increments

Display

Dimensions/appearance	Width × height: 51,3 mm × 38,8 mm, also refer to Dimensions and options
Number of digits on LC display	2 rows with 5 digits each
Display mode	Pressure + min/max or pressure + temperature, additional bar graph
Measuring rate (standard)	2 measurements per second
Measuring rate (peak mode)	5 kHz (reduced resolution and accuracy)
Configurable units of pressure	[bar], [mbar], [Pa], [hPa], [kPa], [MPa], [PSI], [mH ₂ O], [cmH ₂ O], [inH ₂ O], [ftH ₂ O], [mmHg], [inHg], [kp/cm ²]
Additional units of pressure	5 user-defined units can be configured

Mechanical Data

Materials in contact with media

Pressure connection	Stainless steel AISI 316L
Pressure transducer separating diaphragm	Stainless steel AISI 316L
Pressure transducer seal (internal)	FKM (Viton® type A)
Pressure connection seal (external)	FKM (Viton® type A)

Other materials

Display housing	Stainless steel AISI 304
Oil filling pressure transducer	Silicone oil

Further details

Pressure connection	G1/4	Other options see available pressure connections
Diameter × height × depth	Approx. 82 mm × 135 mm × 40 mm	Without rubber cover
	Approx. 90 mm × 139 mm × 45 mm	With rubber cover
Weight	Approx. 430 g	
Protection	IP66	

Whilst every effort has been made to ensure the accuracy of this specification, we cannot accept responsibility for damage, injury, loss or expense from errors or omissions. In the interest of technical improvement, this specification may be altered without notice.

For pricing or any further information, please contact Omni Instruments Ltd.

LEO5 – Dimensions and Options

LC Display

Front cover	Content	Dimensions
		Width x height: 51,3 mm x 38,8 mm Digit height: top: 15 mm x 7 mm bottom: 10,5 mm x 4,5 mm

External Connection

Placement	Mini USB-B connection

Available Pressure Connections

G1/4 (standard)	G1/2	1/4 NPT	1/2 NPT	G1/2 EN 837
G1/2 flush	G3/4 flush	7/16-20 UNF	Clamp DIN 32676 flush	G1/4 EN 837

Other pressure connections available upon request.

G3/4

Optional Advanced Versions

Standard	Detached sensors

Other Customer-specific Options

- Evaluation on other pressure areas
- Evaluation on other temperature ranges
- Parts that come into contact with media made from Hastelloy, Inconel or titanium
- Customer-specific front covers
- Customer-specific firmware with e.g. application-specific calculations
- Other sealing materials for pressure transducers
- Other oil fillings for pressure transducers

G1/4"

For pricing or any further information, please contact Omni Instruments Ltd.

LEO5 – Software, Scope of Delivery and Accessories

Interface

The LEO5 manometer has a USB interface. Details of the communication protocols can be found at www.keller-druck.com. Documentation, a Dynamic Link Library (DLL) and various programming examples are available to integrate the communication protocol into your own software.

KOLIBRI Desktop

With the «KOLIBRI Desktop» Windows software, data recorded using KELLER instruments with a recording function can be read and visualised. This data can be exported in CSV, JSON, Excel or Word format, as an image, or in other formats for further processing or documentation. The data loggers are easy to configure, thanks to the intuitive software interface. And, the various recording functions provide an optimum level of adaptability to suit the measuring task at hand. Additionally, installation site information and other parameters necessary for water level calculations can be saved directly in the measuring device.

KOLIBRI Desktop is license-free and compatible with all products of the KOLIBRI Suite

Configuration options

- Pressure and temperature channels, selectable.
- Adjustable measurement interval (1s...99 days)
- Averaging with selectable number of measurements
- Recording modes
 - continuous interval measurement
 - event-controlled recording
 - recording starts when value is exceeded
 - recording starts when value is undercut
 - recording starts when value changes
 - combination of continuous and event-controlled recording is possible
- Adjustment of pressure zero point
- Start measurements immediately or at a set time
- Water level calculation
- Data storage: linear or ring-type memory



«CCS30» Software

Recording measured values

- Live visualisation
- Adjustable measuring and storage interval
- Export function

Configuration

- Call up of information (pressure and temperature range, firmware version, serial number etc.)

«ManoConfig» Software

The ManoConfig program is compatible with various types of KELLER manometers and allows end customers to configure the devices.

Range of functions

- Display of online measured values
- Configuring the wait period before automatic shutdown
- Selecting standard pressure units
- Activating/deactivating pressure units
- Programming user-defined pressure units
- Restoring to factory settings
- Calibrating the manometer

Whilst every effort has been made to ensure the accuracy of this specification, we cannot accept responsibility for damage, injury, loss or expense from errors or omissions. In the interest of technical improvement, this specification may be altered without notice.

For pricing or any further information, please contact Omni Instruments Ltd.

LEO5 – Software, Scope of Delivery and Accessories

Scope of Delivery

Plastic case	USB cable	KELLER 5-point report	Operating instructions D/E/F

Accessories

Rubber cover	KELLER 11-point report	Calibration certificate
For additional protection in harsh environments	Measurement deviation at room temperature with hysteresis	Issued by the external calibration laboratory of the German accreditation body DAkkS or the Swiss accreditation body SAS

Whilst every effort has been made to ensure the accuracy of this specification, we cannot accept responsibility for damage, injury, loss or expense from errors or omissions. In the interest of technical improvement, this specification may be altered without notice.

For pricing or any further information, please contact Omni Instruments Ltd.