



Technical Overview

The AV-D is a single point, multi-range air velocity transmitter with user selectable 0-10Vdc or 4-20mA outputs and 4 user selectable measurement ranges. The unit has a built-in self-test feature and the user can manually override the output to 0%, 50% or 100% of output range to aid commissioning.

A flange plate (DPA) is available for adjustment of the penetration depth.

Features & Benefits

- User selectable output signal, 0-10Vdc or 4-20mA
- User selectable measurement ranges
- Durable and resistant to chemical reagents
- Adjustable probe depth using the optional DPA
- Built-in self-test feature

Product Codes

AV-D Single point multi-range air velocity transmitter

Accessory

DPA Duct probe adjustment flange

Specification

Output ranges:	0 to 4 m/s	0 to 8 m/s
	0 to 16 m/s	0 to 32 m/s
Accuracy ($\pm 3\%$ of range)	0 to 4 m/s	± 0.12 m/s
	0 to 8 m/s	± 0.24 m/s
	0 to 16 m/s	± 0.48 m/s
	0 to 32 m/s	± 0.96 m/s
Outputs:	4-20mA, 100 Ω loop resistance min.	
	0-10Vdc into 4.7k Ω min	
Supply (current output):	20Vdc to 35Vdc for 500 Ω loop resistance	
	12Vdc to 30Vdc for 100 Ω loop resistance	
Supply (Voltage output):	17Vdc to 34Vdc	
	14Vac to 26Vac supply into 4.7k Ω min.	
Max. current	50mA	
Speed of response	3 seconds for 90% change	
Housing:	Material PC/GF (Halogen free, flame retardant & UV stabilized)	
	Dimensions 125 x 105 x 85mm	
Probe:	Material Delrin	
	Dimensions 215mm x 19mm dia.	
Environmental:	Housing: -30 to 60°C	
	Media: 0 to 95% non-condensing	
	-10 to +50°C	
Protection	IP65	
Country of origin	Denmark	

WEEE Directive:



At the end of the products useful life please dispose as per the local regulations. Do not dispose of with normal household waste. Do not burn.



The products referred to in this data sheet meet the requirements of EU Directive 2014/30/EU

For pricing or any further information, please contact Omni Instruments Ltd.

Contact Details:

Tel: +44 1382 443000
 Fax: +44 1382 453197
 Email: info@omni.uk.com

Mailing Address: Unit 1, 14 Nobel Road,
 Wester Gourdie Industrial Estate,
 Dundee, DD2 4UH.

Website: www.omniinstruments.co.uk

Installation



Antistatic precautions must be observed when handling these sensors. The PCB contains circuitry that can be damaged by static discharge.

Transmitters should only be fitted to a system after airflow calibration has been carried out and preferably following full fan running of at least several days, in order that the main contaminants have been removed from the stagnant system.

1. Fit the housing to the duct with appropriate screws, or by using the optional duct mounting flange.
 2. Release the snap-fit lid by gently squeezing the locking tab.
 3. Feed the cable through the waterproof gland and terminate the cores at the terminal block leaving some slack inside the unit, tighten the cable gland onto the cable to ensure water tightness.
 4. If the sensor is to be mounted outside, it is recommended that the unit be mounted with the cable entry at the bottom. If the cable is fed from above then into the cable gland at the bottom, it is recommended that a rain loop be placed in the cable before entry into the sensor.
 5. Set jumper links according to output type required. Snap shut the lid after the connections have been made.
 6. It is recommended that screened cable be used and that the screen should be earthed at the controller. Care should be taken not to lay control signal wiring in close proximity to power or other cables which may produce significant electromagnetic noise.
 7. Allow 3 minutes before checking functionality and allow 30 minutes before carrying out pre-commissioning checks.
- The AV-D should be installed not less than 2 metres downstream from any heating or cooling devices, source of moisture such as humidifier, fan or bend in the ductwork.
 - To ensure accurate readings the AV-D should be installed so that the element is $0.24 \times$ the duct radius into the duct.

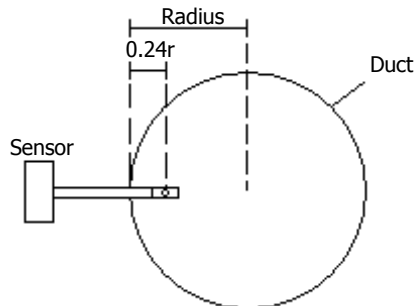

- Reading errors of up to 30% may be experienced if the elements are positioned in the centre of the duct.
- The AV-D should be mounted with the holes in the end of the probe orientated directly into the air flow, to allow full air flow over the sensing element.
- The AV-D requires approx. 50mA. Ensure the supply to the sensor is capable of providing this current.
- If using a current output mode, the sensor must only be used with a 24Vdc supply. The sensor may be damaged if supplied with AC.

Note: When using current output mode they are NOT loop powered and will require a common 0V connection.

For pricing or any further information, please contact Omni Instruments Ltd.



Connections, Jumper Settings & Output Range:

Current output

If using a current output mode, the sensor must only be used with a 24Vdc supply. The sensor may be damaged if supplied with AC.
 Note: When using current output mode they are **NOT** loop powered and will require a common 0V connection.

Output Signal Jumper Settings

0-10Vdc (U)



4-20mA (I)



NB Standard units are factory set for a 0-10Vdc output.

Output Range Dip-switch Settings

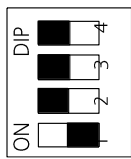

Output range	Dip switch			
	1	2	3	4
0 to 4m/s	ON	OFF	OFF	OFF
0 to 8m/s	OFF	ON	OFF	OFF
0 to 16m/s	OFF	OFF	ON	OFF
0 to 32m/s	OFF	OFF	OFF	ON

Example: 0-4m/s (0-787ft/min), the "raised" section of the dip switch is pushed towards the ON position. (indicated by the white square)

Connections

- **Out** 0-10Vdc or 4-20mA output
- **Gnd** Common 0V
- **+IN** 24Vac/dc supply voltage (see notes)

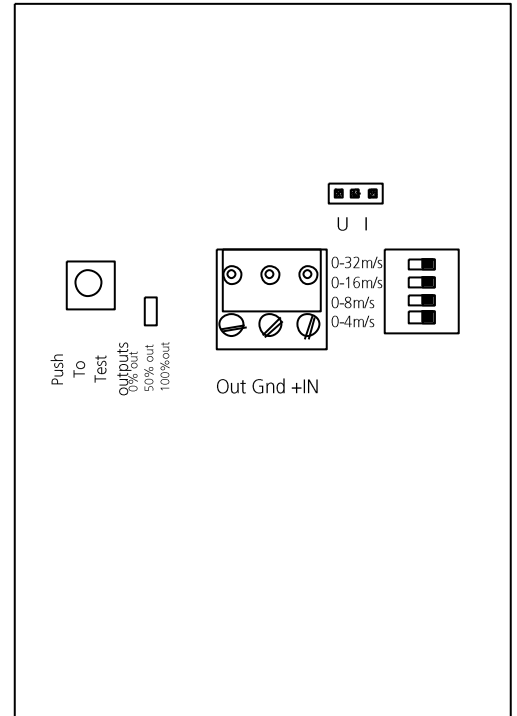

Self-Test, Manual Override & Failure Mode:

The output of the AV-622 can be manually overridden to one of 3 values by pressing the PCB mounted button. When this button is pressed once, the output will change to 0% of the output's range, when pressed again the output will change to 50% of the output's range and when pressed a third time will change the outputs to 100% of the outputs range. Pressing again will return the outputs to automatic control.

Example:

- First Press Velocity output falls to 0%, LED flashes slowly.
- Second Press Velocity output rises to 50%, LED flashes slowly.
- Third Press Velocity output rises to 100%, LED flashes slowly.
- Fourth Press Velocity output reverts to automatic levels. The LED should be permanently on.

If the sensor element assembly is damaged, the output will change to the following fixed default value and the LED will flash rapidly;

Velocity = 0%

Whilst every effort has been made to ensure the accuracy of this specification, we cannot accept responsibility for damage, injury, loss or expense from errors or omissions. In the interest of technical improvement, this specification may be altered without notice.

For pricing or any further information, please contact Omni Instruments Ltd.