



# TORQSENSE®

## SGR530/540 Series Rotary Torque Transducer



## Digital SGR530/540 series Torque Transducer

Torqsense Digital rotary strain gauge SGR530/540 series Transducers with separate electronics use non contact technology eliminating the need for noisy slip rings. They are suitable for torque measuring, testing, feedback control of drive mechanisms and process control applications.

The SGR series transducers use modern strain gauge signal conditioning techniques to provide a high bandwidth low cost torque measuring solution with high overrange and overload capabilities.

### Benefits & Features

- Transducers from 1Nm to 13000Nm.
- Large fully functional overrange capability of 250% (SGR 540)
- Separate digital electronics
- Minimal side and end load errors
- Low linearity deviation of  $\pm 0.05\%$  FSD
- Low hysteresis error of  $\pm 0.05\%$  FSD
- Zero variation in torque signal with rotation (cyclic variation)
- Non contact signal transmission, no slip rings to wear out
- High digital sample rate of 4000 samples per second
- Adjustable torque data smoothness, low pass filter (SGR540)
- Speed measurement / Power computation
- Wide power supply range 12-32 VDC
- Compatible with ethernet gateway module

### Technology

The SGR series torque transducers use a full four element strain gauge bridge to measure the torsion present on a shaft. The full bridge helps to diminish errors from any off-axis forces that are sometimes unintentionally applied to the transducer in some test setups. The full bridge also increases the sensitivity and the temperature performance of strain measurement.

A rotor mounted ultra-miniature microcontroller measures the strain gauge bridge and transfers the information back to the stator digitally eliminating any noise pickup usually associated with slip ring and other analog methods of transferring torque data from rotor to stator. External noise pickup into the gauge wiring is virtually eliminated due to the short distance between the strain gauge elements and the rotors measuring circuits.

A multipoint calibration method reduces any linearity errors within the sensor. A large functional overrange capability allows the peaks of a torque signal to be captured more faithfully without any clipping when operating the sensor close to its full scale rating.

All this combined with a mechanical overload capability of over 400% make the SGR series torque sensors a very robust and accurate torque measuring solution.

### TorqSense SGR530 series transducers offer:

- Fixed voltage or current analog outputs (one for torque and the other for speed or power) for interfacing with analog instrumentation
- BIT Self-diagnostics for letting the manufacturer know that the transducer's torque, speed ratings and calibration due date have not been exceeded.
- Simple 'Sensor status' output pin
- Sensors to monitor shaft temperature for better compensation and accuracy

### Whereas, TorqSense SGR540 series transducers offer:

- Digital outputs, such as RS232, CANbus and USB, for interfacing with modern instrumentation and laptops
- Digital input for configuring transducer via PC
- 2 x user selectable voltage or current analog outputs (one for torque and the other for speed, power or peak torque) for interfacing with analog instrumentation
- Transducer configuration software to allow user to change transducer variables
- BIT Self-diagnostics for letting users know data is trustworthy, that the transducer's torque, speed ratings and calibration due date have not been exceeded
- Simple 'Sensor status' output pin
- Sensors to monitor shaft temperature for better compensation and accuracy
- Ability to connect up to 10 transducers using USB
- Optional external ethernet gateway module

### TORQVIEW Software

TorqView is an easy to use advanced torque monitoring software, available to assist data recording and instrumentation displays that interface with Windows based PCs.

Features include: 3 types of display, text files compatible with Matlab and Excel and Real time chart plotting. See TorqView datasheet for more details.



LabView VI's are available for users to design their own process control applications. DLLs are also available for users to write their own custom software. Get data from across your network using the ethernet module.

SGR530/540 Series Torque Transducers - Data Specification

Parameter	Condition	Data								Units
<b>SGR530/540 Torque measurement system</b>										
Measurement method		Full bridge strain gauge								
Torque range	<i>(See Notes 1 &amp; 2 below)</i>	0 – 1	0 – 1.1 to 0 - 20	0 – 21 to 0 - 100	0 – 101 to 0 - 500	0 - 501 to 0 - 2000	0 – 2001 to 0 - 13000		Nm	
		[0 - 10]	[0 - 11 to 0 - 200]	[0 - 201 to 0 - 1000]	[0 - 1001 to 0 - 5000]	[0 - 5001 to 0 - 20000]	[0 - 20001 to 0 - 175000]		[lbf·in]	
Shaft size (diameter)		6	12	20	30	50	75		mm	
<b>Specifications</b>										
Combined non-linearity and hysteresis		±0.1								%FS
Resolution		0.01								%FS
Repeatability		0.05								%FS
<b>SGR530 Series Transducers ONLY</b>										
Accuracy	20°C, SM <i>(See Note 4)</i>	±0.2								%FS
3dB Bandwidth	<i>(See Notes 5&amp;6)</i>	250 (default ave. = 16)								Hz
<b>Analog output</b>										
Output voltages (Torque/Speed/Power)		Options available: ±1 / ±5 / ±10 / Unipolar (SGR530 Series default setting is ±5Vdc) (SGR540 Series output voltages are user selectable)								Vdc
Load impedance		Maximum 1								KΩ
Output currents (Torque/Speed/Power)		Options available: 4-20 / 0-20 / 12±8 (SGR540 Series output currents are user selectable)								mA
4-20mA Loop resistance		Should not exceed 400								Ω
<b>SGR540 Series Transducers ONLY</b>										
Accuracy	20°C, SM <i>(See Note 4)</i>	±0.1								%FS
Digital averaging	<i>(See Note 5)</i>	2	4	8	16	32	64	128	256	N
Noise Floor	20°C, SM <i>(See Note 4)</i>	0.06	0.04	0.03	0.02	0.015	0.01	0.01	0.01	%FS
3dB Bandwidth	<i>(See Note 6)</i>	2000	1000	500	250	125	62	31	15	Hz
<b>Digital output (SGR540 Series Transducers ONLY)</b>										
Connections		CAN Bus			RS232		USB			
Configuration		CAN 2.0B, 11bit Message Identifiers			Data Bits: 8, Parity: None, Stop Bits: 1		USB 2.0 Full-Speed			
Baud Rate(s)		1 Mbps, 500 Kbps, 250 Kbps, 100 Kbps			115200 bps, 38400 bps, 9600 bps		12 Mbps			
Output Rate <i>(Note 7)</i>		Up to 10 KHz			Up to 1.1 KHz		Single Transfer	Up to 500 Hz		
							Bulk Transfer	Up to 10 KHz		
<b>Rotation speed/angle of rotation measurement system</b>										
Measurement method		Opto switch through slotted disc								
Direct output signal		Pulse output direct from opto switch (TTL, 5V square wave)								
Accuracy		±1rpm up to 30,000rpm								
Rotational speed (max)	<i>(See Note 3)</i>	30,000	20,000	15,000	12,000	9,000	6,000		RPM	
Digital Processing Techniques Processing modes run simultaneously and can be applied to either analog channel or accessed individually via a digital connection.		Processing Method			Update rate for analog and digital outputs					
		Mode 1 (Slow Method)Frequency Count			1					Hz
		Mode 2 (Fast Method)Period Count			0 RPM	1				Hz
					< 2000 RPM	RPM				
					> 2000 RPM	RPM x ( 1 / ( ⌊ (RPM - 1) / 2000 ⌋ + 1 ) )				
<b>Temperature</b>										
Measurement method		Shaft mounted platinum temperature sensor								
Temperature accuracy		±1								°C
Reference temperature T <sub>RT</sub>		20								°C
Operating range, ΔT <sub>O</sub>		-10 to +50								°C
Storage range, ΔT <sub>S</sub>		-20 to +70								°C
Temperature		Coefficient of zero 0.002								%
Temperature		Coefficient of span 0.01								%
<b>Power supply</b>										
Nominal voltage, V <sub>S</sub>		12 to 32 (max)								V
Current consumption, I <sub>S</sub>		250 (max) @ 12 VDC								mA
Power consumption, W <sub>S</sub>		3								W
Allowed residual ripple of supply voltage, V <sub>ripple</sub>		500 (above nominal supply voltage)								mVp-p
<b>Electromagnetic compatibility</b>										
EMC compatibility		EN 61326:2006								

\* For notes, please see glossary page

# SGR530/540 Series Torque Transducers

## Dimensions (1Nm to 100Nm)

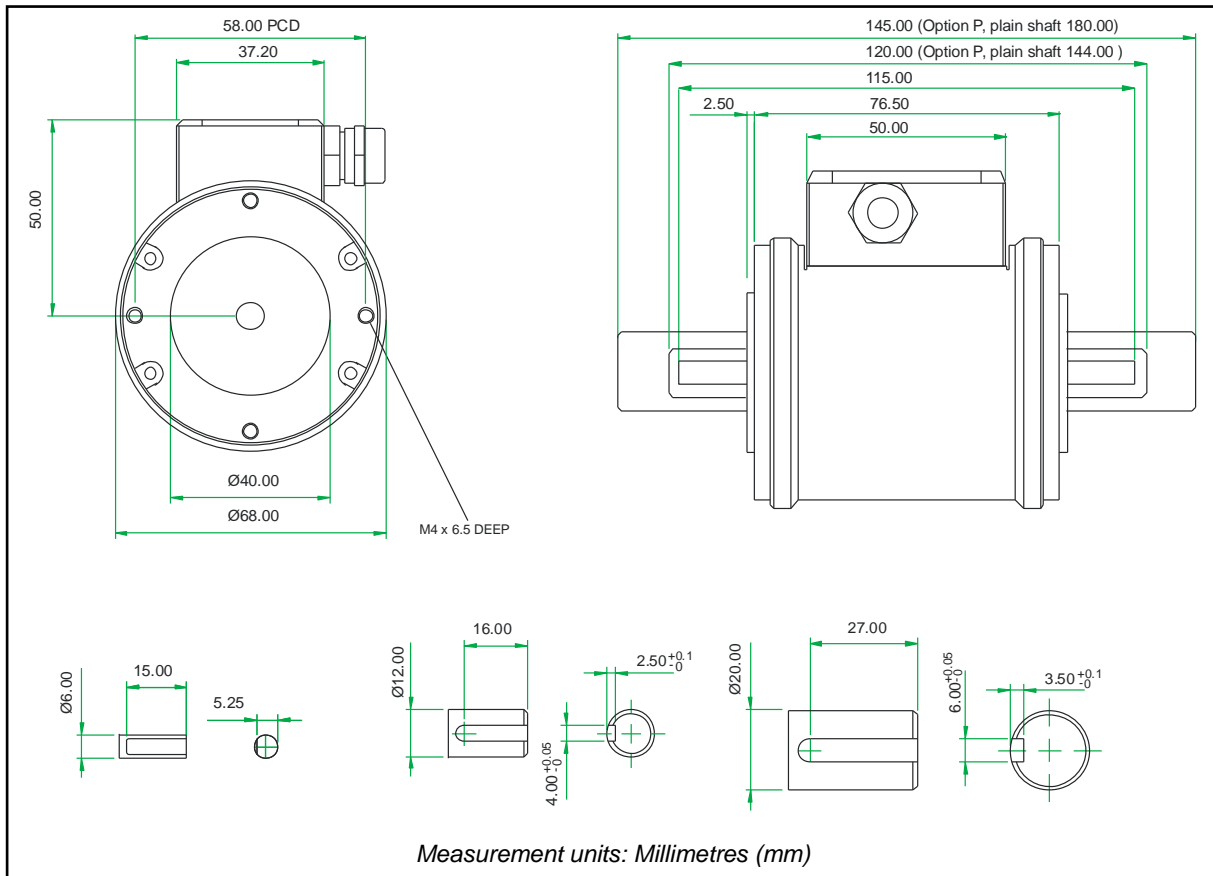

Parameter	Data												Units
Torque (Max)	1	2.5	3.9	6	8.5	13	17.5	20	30	55	85	100	Nm
Shaft Code	CF	DA	DF	DB	DC	DG	DD	DE	EB	EC	ED	EE	
Shaft Size (Diameter)	6	12						20					mm
Torsional Stiffness	0.23	1.28	1.3	1.32	1.6	1.7	1.8	1.9	4.1	6.4	8.1	9.2	KNm/rad
Mass moment of inertia, $I_v$	0.45	5.96	6.00	6.04	6.13	6.18	6.24	6.42	22.9	23.9	25.4	27.2	$\times 10^{-6}$ kg.m <sup>2</sup>
Max measurable load limit	120 (of rated torque)												%
Static safe load breaking	300 (of rated torque)												%
Shaft weight, approx	0.03	0.14	0.14	0.14	0.14	0.15	0.15	0.15	0.36	0.37	0.40	0.41	kg
Transducer with shaft weight, approx (1 dp)	0.5	0.6	0.6	0.6	0.6	0.7	0.7	0.7	0.9	0.9	0.9	0.9	kg

# SGR30/540 Series Torque Transducers

## Dimensions (101Nm to 500Nm)

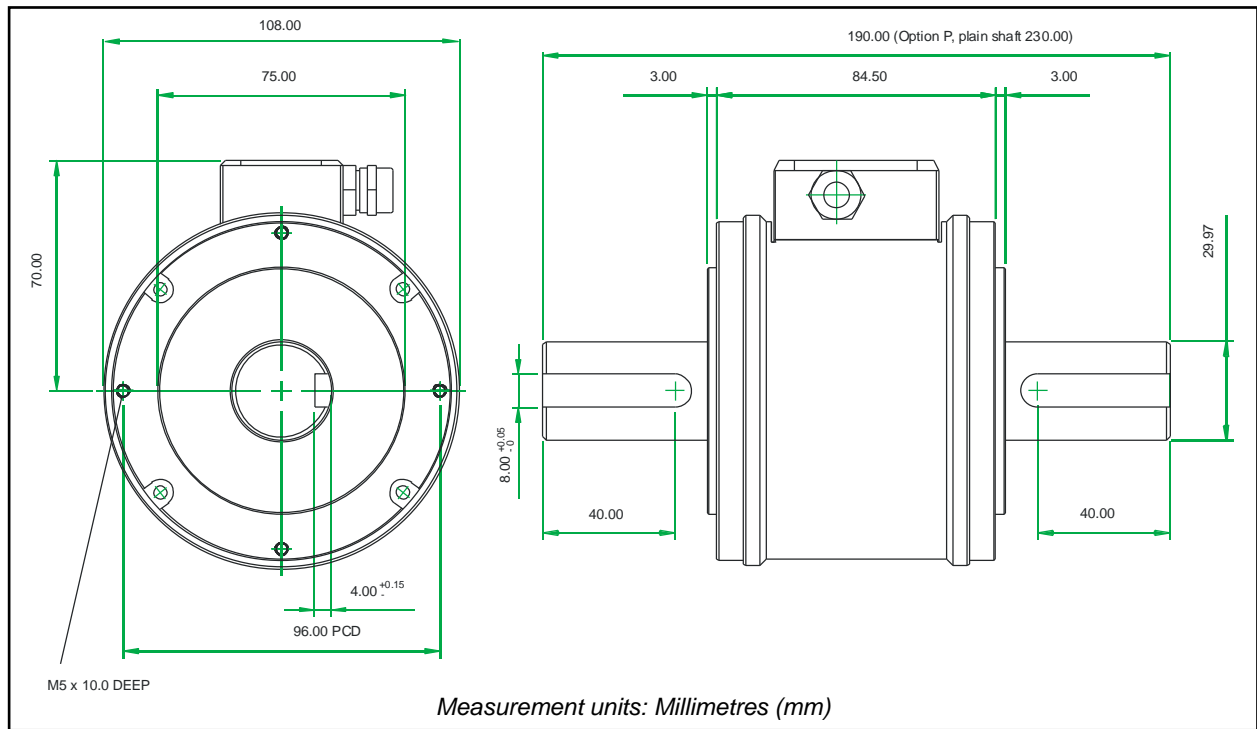

Parameter	Data					Units
<b>Mechanical Properties</b>						
Torque (Max)	175	225	265	350	500	Nm
Shaft Code	FA	FB	FC	FD	FE	
Shaft Size (Diameter)	30					mm
Torsional stiffness	32.9	35.6	37.2	37.9	39.8	kNm/rad
Mass moment of inertia	138.9	143.1	147.7	151.9	174.2	$\times 10^{-6} \text{ kg m}^2$
Max measurable load limit	120 (of rated torque)					%
Static safe load breaking	300 (of rated torque)					%
Shaft weight, approx	1.1	1.1	1.1	1.2	1.2	kg
Transducer with shaft weight, approx (1 dp)	2.3	2.3	2.3	2.4	2.4	kg

# SGR530/540 Series Torque Transducers

## Dimensions (501Nm to 13000Nm)

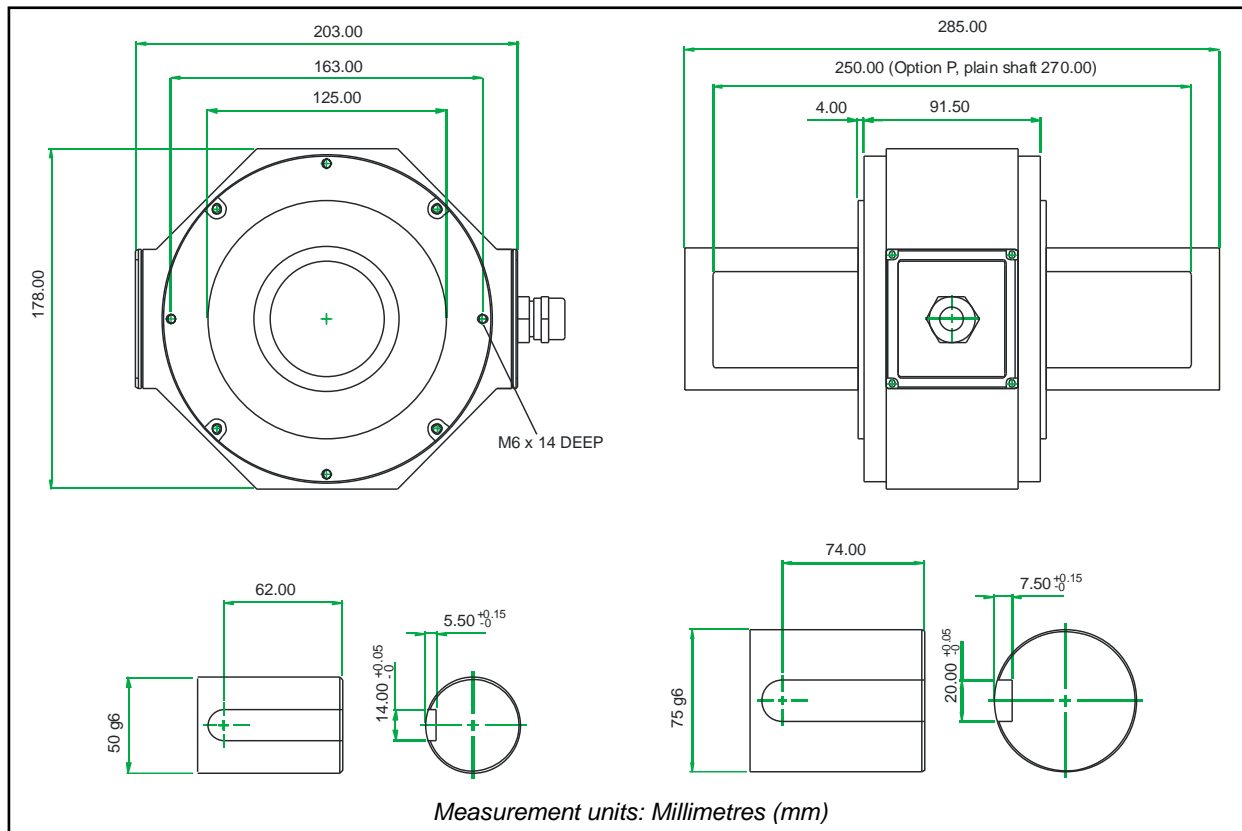

Parameter	Data										Units
<b>Mechanical Properties</b>											
Torque (Max)	650	850	1100	1350	2000	3000	4000	6000	10000	13000	Nm
Shaft Code	GE	GA	GB	GC	GD	HA	HB	HC	HF	HG	
Shaft Size (Diameter)	50					75					Mm
Torsional Stiffness	TBC	TBC	199.2	TBC	214.1	TBC	TBC	914.4	945.5	TBC	kNm/rad
Mass moment of inertia	TBC	TBC	1330	TBC	1497	TBC	TBC	7932.7	9407.1	TBC	$\times 10^{-6}$ kg m <sup>2</sup>
Max measurable load limit	120 (of rated torque)										%
Static safe load breaking	300 (of rated torque)										%
Shaft weight, approx	TBC	TBC	3.9	TBC	4.1	TBC	TBC	10.2	10.6	11.2	kg
Transducer with shaft weight, approx	TBC	TBC	7.1	TBC	7.3	TBC	TBC	13.4	13.8	14.4	kg

SGR530/540 Series Electronics Module

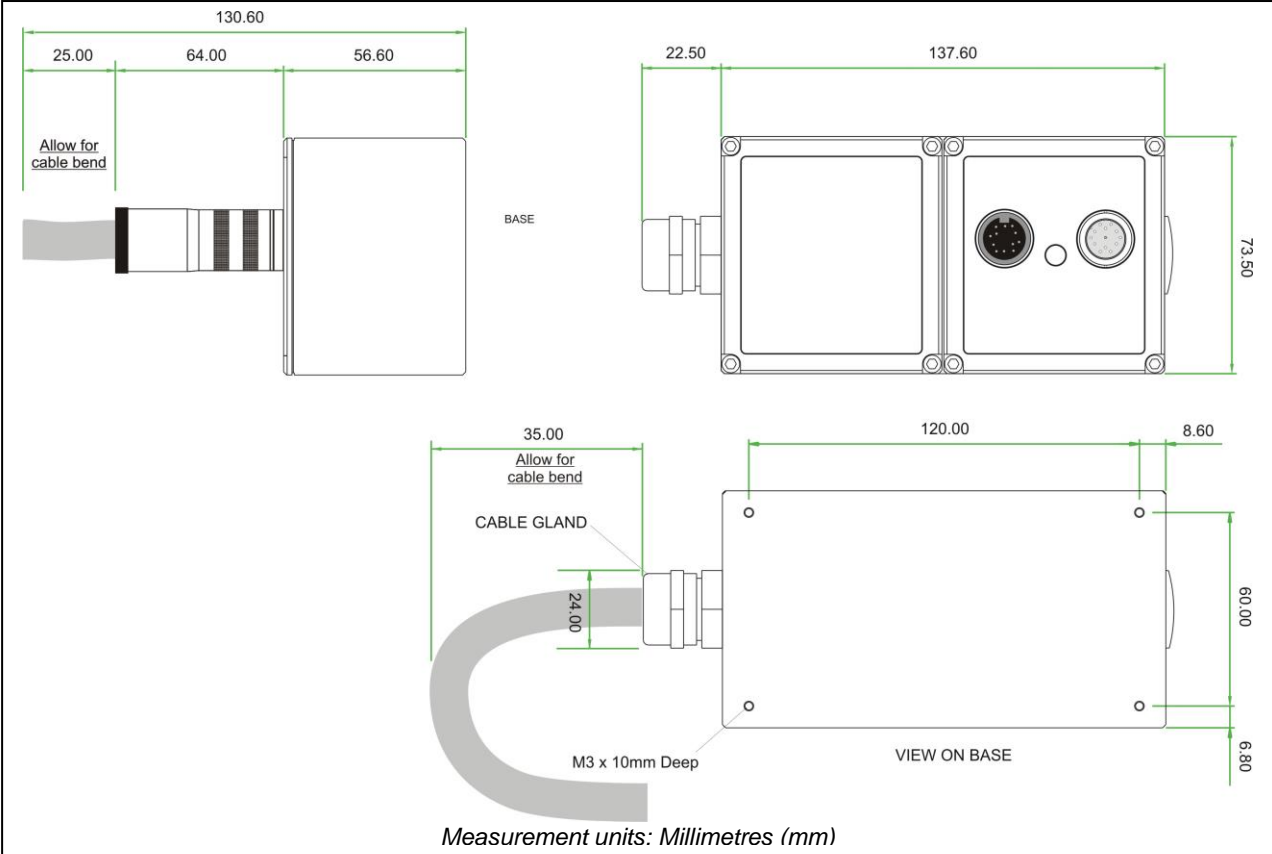

SGR530/540 Series Torque Transducers - Standard Range

● – Standard feature    ◇ – Optional feature

	SGR530/540 Series		Option Code	Remarks
<b>Torque, Speed, Power Outputs</b>	<b>SGR530</b>	<b>SGR540</b>		
Torque only	530	540		
Torque & Speed (60 pulses/rev)	531			User to specify RPM/FSD when ordering
Torque & Speed (360 pulses/rev)	532			Not yet available
Torque & Power (60 pulses/rev)	533			User to specify Power/FSD when ordering
Torque & Speed (60 pulses/rev) or Power		541		Outputs are user selectable
Torque & Speed (360 pulses/rev) or Power		542		Not yet available
<b>Standard features</b>				
Keyed Shaft Ends	●	●	K	1Nm will have flats
Voltage output ±5v FSD (Fixed)	●		B	
Voltage outputs from ±1v to ±10v FSD and unipolar (Variable)		●		Output is user selectable
USB 2.0 full speed 12 Mbps Digital output		●		
RS232 output		●		
Torque Averaging and Torque Peak		●		
Self Diagnostics	●	●		
Internal temperature measurement	●	●		Value available on SGR540 series only
Deep grooved shielded bearings with oil lubrication	●	●		
Ingress Protection (IP) 54	●	●		
<b>Optional features</b>				
Plain Shaft Ends	◇	◇	P	Shaft length will be longer than keyed end shafts – consult factory for length
Splined Shaft Ends	◇	◇	T	Consult factory for details
Voltage output ±1v FSD (Fixed)	◇		A	In place of Option B
Voltage output ±10v FSD (Fixed)	◇		C	In place of Option B
Customer Specified Voltage Output (Fixed)	◇		U	In place of Option B. User to specify range/scale when ordering
Current output 0-20mA (Fixed)	◇		D	In place of Voltage output options
Current output 4-20mA (Fixed)	◇		E	In place of Voltage output options
Current output 12±8mA (Fixed)	◇		V	In place of Voltage output options
Current output 0-20mA, 4-20mA & 12±8mA (Variable)		◇	F	Current output is user selectable and in place of Voltage output. However user can reselect a Voltage output, if required. (Note 8)
CANbus output		◇	H	In place of RS232 output
High Speed Bearings (See Note 9 below)	◇	◇	J	Consult factory for maximum speed allowance.
Sealed Bearings	◇	◇	S	
Ingress Protection (IP) 65 (See Note 10 below)	◇	◇	L	



## SGR530/540 Series Torque Transducers – Connector and Lead Options

	SGR530/540 Series		Option Code	Remarks/Purpose
	SGR530	SGR540		
Connectors & Leads				
Analog Connector <i>12 Pin Lumberg (female)</i>	◇	◇	ACC 1	<i>For user to self wire</i>
Digital Connector <i>12 Pin Lumberg (male)</i>		◇	ACC 2	<i>For user to self wire</i>
Analog Lead (Length 2.5m) <i>12 Pin Lumberg (female) to 15 way 'D' type connector (female)</i>	◇	◇	ACC 3	<b><i>For connecting SGR to user's system via 15 pin 'D' connector</i></b>
Digital Lead (Length 2.5m) <i>12 Pin Lumberg (male) to 15 way 'D' type connector (male)</i>		◇	ACC 4	<b><i>For connecting SGR to user's system via 15 pin 'D' connector</i></b>
Digital Lead Adapter (Length 1m) <i>15 Way 'D' type (female) to RS232 and Power Connectors</i>		◇	ACC 5	<i>For connecting SGR to PC via RS232 [Also needs Digital Lead (ACC4) to connect to SGR]</i>
Digital Lead Adapter (Length 1m) <i>15 Way 'D' type (female) to RS232, USB and Power Connectors</i>		◇	ACC 6	<i>For connecting SGR to PC via USB (Option G) or RS232 [Also needs Digital Lead (ACC4) to connect to SGR]</i>
Digital Lead Adapter (Length 1m) <i>15 Way 'D' type (female) to CANbus and Power Connectors</i>		◇	ACC 8	<i>For connecting SGR to PC via CANbus (Option H) [Also needs Digital Lead (ACC4) to connect to SGR]</i>
Digital Lead Adapter (Length 1m) <i>15 Way 'D' type (female) to CANbus, USB and Power Connectors</i>		◇	ACC 9	<i>For connecting SGR to PC via USB (Option G) or CANbus (Option H) [Also needs Digital Lead (ACC4) to connect to SGR]</i>

## SGR530/540 Series Torque Transducers – Additional related products

	Code	Remarks/Purpose
Transducer Display ETD	ETD	<i>Display readout</i>
AC Mains Adapter Power Supply	PSU 1	<i>For providing 12-32Vdc</i>
Transducer Signal Breakout Unit	SBU 1	
TorqView	TV	<i>Torque Monitoring Software</i>
Ethernet Module	E-NET-01	<i>Getting data on to the network</i>

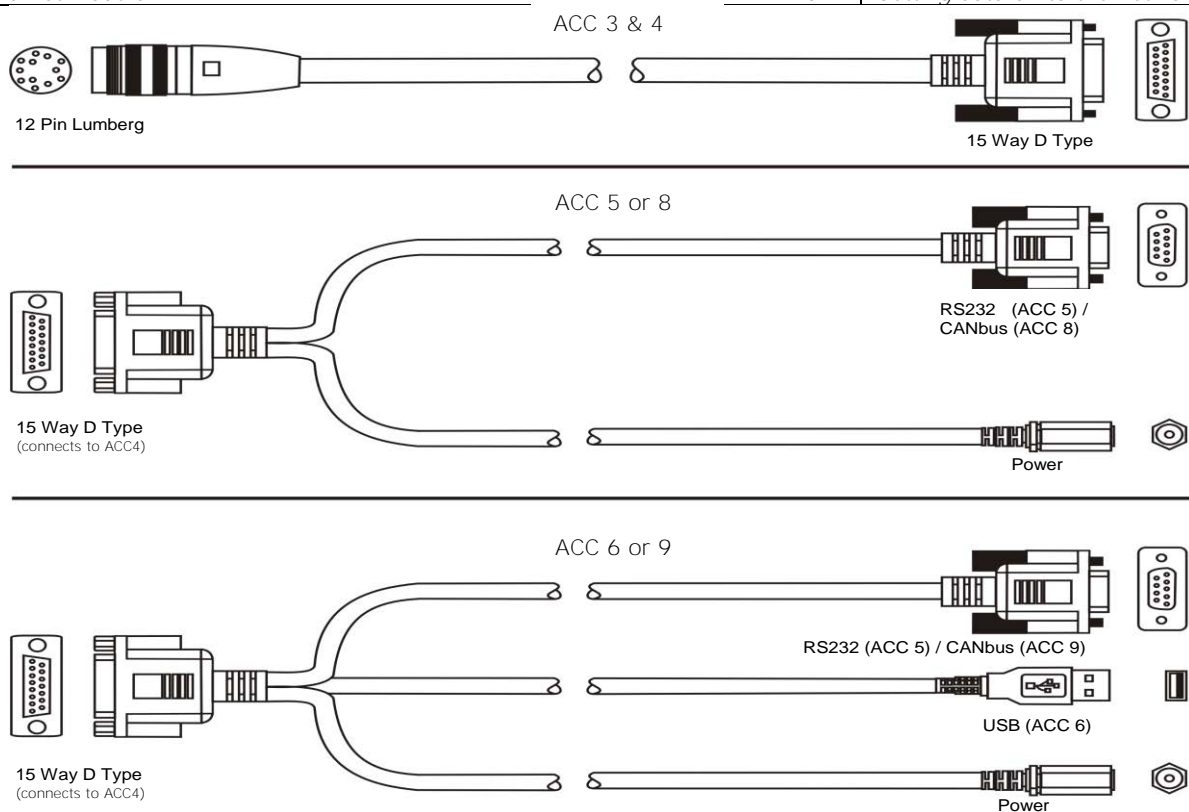

For example: SGR	531 - 15Nm -	K-CL	A 'basic' transducer with torque and speed outputs, rated and calibrated to 15Nm FSD with keyed ends, ±10v and IP65 protection.
Your transducer requirement: SGR			
Max speed (if applicable)		RPM	
Connector or Lead options			
Additional related products			

### Glossary of terms and definitions used in this datasheet

- **Accuracy** - The degree of conformity of a measured or calculated quantity, which will show the same or similar results. Accuracy of the overall TorqSense system is limited by the combined error of several factors such as linearity, hysteresis, temperature drifts and other parameters affecting measurements. If errors in the system are known or can be estimated, an overall error or uncertainty of measurement can be calculated.
- **Digital averaging** – The application of algorithms to reduce white noise. In any electronic system, electronic white noise is mixed with the signal and this noise usually limits the accuracy. To reduce the influence of white noise and increase the accuracy of the system different averaging algorithms can be applied. In the TorqSense system a flying digital averaging technique is applied to reduce the white noise commensurate with the level of accuracy required. However, as any averaging algorithm works as a low pass filter, the more averaging that is applied the lower the frequency response. Therefore, each Torqsense system should be optimised to **the customer's requirements by choosing the right combination of accuracy/frequency response. Please see relevant part of the Datasheet and User Manual.**

Note 1: Any torque/FSD is possible between ranges – please specify max rated torque.

Note 2: Max rated torque should not be exceeded.

Note 3: Please consult factory for applications requiring rotational speeds that exceed maximum figures given. Transducers fitted for IP65 will have running speeds considerably reduced, increased drag torque and accuracy can be affected.

Note 4: SM – Static Mode. Dynamic values will depend upon user application and has to be adjusted accordingly.

Note 5: Digital averaging can be configured by user to optimise accuracy/frequency response for specific user applications. Digital averaging default setting is N=16. For details see User Manual.

Note 6: >5Khz Sample Rate. Up to 10Khz sample rate possible, please consult factory. Digital averaging also affects the analog output, max analog output 3dB Bandwidth = 5Khz when digital average is 1.

Note 7: Output rate figures are calculated from the time taken to capture 10000 torque readings. Testing was conducted with each connection method configured at its maximum baud rate. The maximum output rate available for CAN and USB is dependant on the transducers setup. USB - USB is a host based bus architecture, because of this the output rate achievable will be affected by other bus traffic and host activity. USB has two transfer modes, Single Transfer which requests 1 reading at a time and Bulk Transfer which transfers readings in blocks of 50 Torque/Speed pairs. CAN Bus - to achieve a Torque reading output rate of 10KHz, the Speed reading output rate must be reduced to 100Hz.

Note 8: 2 x analog channels available. Default settings are Channel 1 (voltage/current) – torque. Channel 2 (voltage/current) – speed or power, if ordered.

Note 9: At very high speeds, for better balance the factory recommend plain or splined shafts.

Note 10: Transducers fitted for IP65 will have running speeds considerably reduced, increased drag torque and accuracy can be affected.