

Series 10L

Piezoresistive OEM pressure transducers with optimum stability

Features

- Optimum long-term stability
- Robust stainless-steel housing
- Front-flush, crevice-free welded diaphragm
- Very high proof pressure
- Optimised thermal behaviour

Technology

- Insulated piezoresistive pressure sensor encapsulated in an oil-filled metal housing
- Ideal for mounting with O-ring
- Typical range of output signal of 160 mV/mA

Typical Applications

- OEM
- Industry
- Laboratory

Accuracy

± 0,25 %FS

Long-term Stability

± 0,15 %FS/year

Pressure Ranges

0...0,1 bar to 0...200 bar

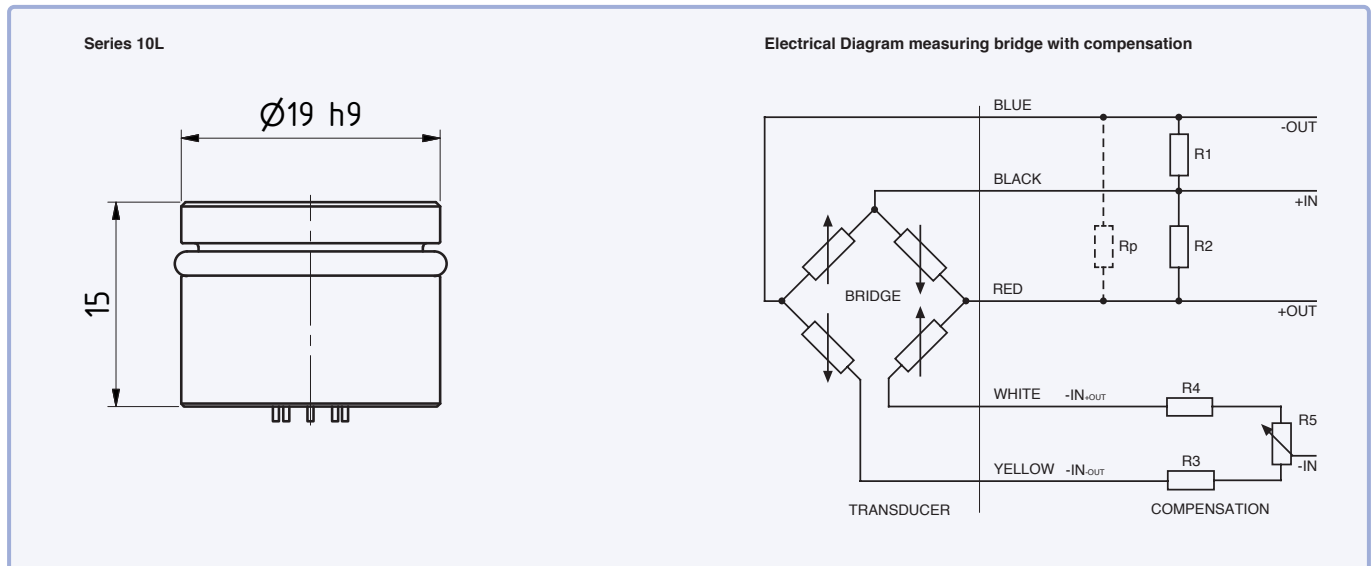

Whilst every effort has been made to ensure the accuracy of this specification, we cannot accept responsibility for damage, injury, loss or expense from errors or omissions. In the interest of technical improvement, this specification may be altered without notice.

For pricing or any further information, please contact Omni Instruments Ltd.

Series 10L – Specifications

Standard Pressure Ranges

Relative pressure		Absolute pressure	Absolute pressure	Proof pressure	Sensitivity		
PR		PAA	PA		min.	typ.	max.
-0,1...0,1	0...0,1	0...0,1		3	98	130	163
-0,2...0,2	0...0,2	0...0,2					
-0,3...0,3	0...0,3	0...0,3					
-0,5...0,5	0...0,5	0...0,5					
-1...0	0...1	0...1	0...1	6	60	80	100
-1...1	0...2	0...2	0...2	9	40	53	66,7
-1...2	0...3	0...3	0...3				
	0...5	0...5	0...5	15	24	32	40
	0...10	0...10	0...10	30	12	16	20
	0...20	0...20	0...20	60	6	8	10
	0...30	0...30	0...30	90	4	5,3	6,7
	0...50	0...50	0...50	150	2,4	3,2	4
		0...100	0...100	300	1,2	1,6	2
		0...160	0...160		0,75	1,0	1,25
		0...200	0...200				
bar rel.		bar abs.	bar	bar	mV/(mA × bar)		
Zero at atmospheric pressure		Zero at 0 bar abs. (vacuum)	Zero at 1 bar abs.	with reference to zero			

Performance

Accuracy @ RT (20...25 °C)	± 0,25 %FS typ.	Non-linearity (BFSL), pressure hysteresis, non-repeatability
	± 0,50 %FS max.	
Offset @ RT (20...25 °C)	< ± 25 mV/mA	Uncompensated
	< ± 2 mV/mA	Compensated with R3 or R4
Long-term stability	≤ ± 0,15 %FS	For pressure ranges > 1 bar, per year under reference conditions
	≤ ± 1,5 mbar	For pressure ranges ≤ 1 bar, per year under reference conditions
Position dependency	≤ 2 mbar	Calibrated in vertical installation position with metal diaphragm facing downwards
Vacuum resistance		Pressure ranges 0,1/0,2/0,3/0,5 bar abs. are vacuum-optimised as standard. For all other pressure ranges, the vacuum-optimised version is recommended for operating pressures ≤ 0,1 bar abs.
Temperature coefficient zero TCzero pre-compensated with R1 or R2	≤ ± 0,015 %FS/K	For pressure ranges ≥ 2 bar
	≤ ± 0,3 mbar/K	For pressure ranges < 2 bar
Temperature coefficient sensitivity TCsens	≤ ± 0,06 %/K	For pressure ranges ≥ 3 bar
	≤ ± 0,12 %/K	For pressure ranges < 3 bar
Temperature coefficient total bridge resistance TC-resistance	1800...3000 ppm/K	

Whilst every effort has been made to ensure the accuracy of this specification, we cannot accept responsibility for damage, injury, loss or expense from errors or omissions. In the interest of technical improvement, this specification may be altered without notice.

For pricing or any further information, please contact Omni Instruments Ltd.

Series 10L – Specifications

Temperature Ranges

Compensated temperature range	-10...80 °C	Optional: Temperature ranges within -55...150 °C possible
Media temperature range	-40...125 °C	
Ambient temperature range	-40...125 °C	
Storage temperature range	-40...125 °C	

Electrical Data

Half-bridge configuration

Constant current supply	1 mA nominal 3 mA max.	
Bridge resistance @ RT (20...25 °C)	3,5 kΩ ± 20 %	
Electrical connection	Gold-plated pins ø 0,45 mm L = 4 mm ± 0,5 mm	Optional: Silicone wires AWG22, L = 70 mm, other lengths on request
Insulation	> 100 MΩ @ 500 VDC	

Mechanical Data

Materials in contact with media

Housing and diaphragm	Stainless steel AISI 316L	Optional: Hastelloy C-276, titanium
Seal ring	FKM (75 Shore) ø 15,6 mm × 1,78 mm -20...200 °C	Optional: Other materials on request

Other materials

Pressure transducer oil filling	Silicone oil	Optional: other oil fillings on request
---------------------------------	--------------	---

Further details

Diameter × height	ø 19 mm × 15 mm	See Dimensions and Options
Reference tube connection	ø 1,2 mm × 3 mm	Optional: Silicone reference tube for reference offset
Weight	approx. 25 g	

Dynamics

Vibration resistance	20 g, 10...2000 Hz, ± 10 mm	IEC 60068-2-6
Shock resistance	50 g, 11 ms	IEC 60068-2-27
Natural frequency (resonance)	> 30 kHz	
Endurance @ RT (20...25 °C)	> 10 million pressure cycles	0...100 %FS
Dead volume change @ RT (20...25 °C)	< 2 mm ³	

Whilst every effort has been made to ensure the accuracy of this specification, we cannot accept responsibility for damage, injury, loss or expense from errors or omissions. In the interest of technical improvement, this specification may be altered without notice.

For pricing or any further information, please contact Omni Instruments Ltd.

Series 10L – Dimensions and Options

Overview of Versions

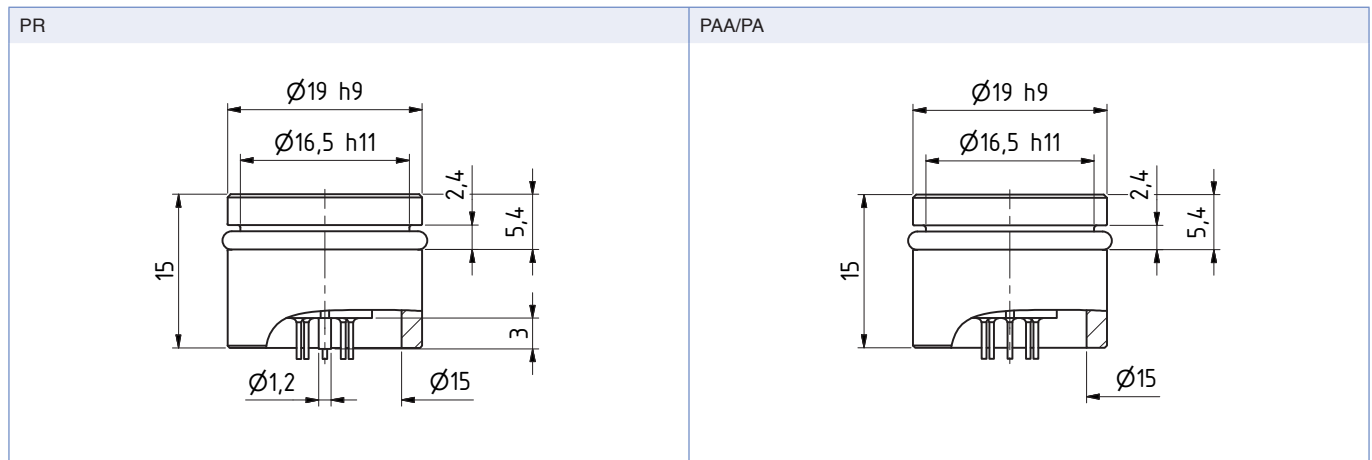

Electrical Connection

Glass feedthrough connection		Half-open measurement bridge pin assignment			
		PIN	Label	Designation	Wire colour
		1	+OUT	Positive Output	red
		2	+IN	Positive Supply	black
		3	-OUT	Negative Output	blue
		4	-IN _{-OUT}	Negative Supply (half bridge -OUT)	yellow
		5	-IN _{+OUT}	Negative Supply (half bridge +OUT)	white

DATENBLATT Glasdurchführung

Overview of Customer-specific Options

- Custom pressure ranges
- Custom temperature ranges
- Custom mathematical modeling
- Electrical connection with silicone wires
- Housing and diaphragm made of Hastelloy C-276 or titanium
- O-Rings made of other materials
- Other oil filling types for pressure transducers: e.g. special oils for oxygen applications
- Vacuum-optimised version for operating pressures $\leq 0,1$ bar abs. on request
- Modifications to customer-specific applications

Related Products

- Series 10LHP: High-pressure version for pressure ranges > 200 bar
- Series PD-10L: Differential pressure version
- Series 10LX: With digital compensation electronics
- Series 4L...9L: More compact designs

Whilst every effort has been made to ensure the accuracy of this specification, we cannot accept responsibility for damage, injury, loss or expense from errors or omissions. In the interest of technical improvement, this specification may be altered without notice.

For pricing or any further information, please contact Omni Instruments Ltd.

Series 10L – Analysis and Characteristic Lines

Standard Analysis

The 10L are intended for o-ring mounting and depend on the stress isolation provided by o-rings for performance within stated specifications. This installation enables the values measured during factory testing to remain valid. If the transducers are not installed free from stress, the mechanical forces may change the measured values and the stability of the pressure transducers.

Calibration sheet: Example type PA-10L		Key																																																																																																																																								
<table border="1"> <tr> <td colspan="5">----- 449</td> </tr> <tr> <td colspan="2">PA-10L / 10 bar / 10-1005-118 ⁽¹⁾</td> <td colspan="3">Sn I107547 ⁽²⁾</td> </tr> <tr> <td colspan="5">----- 29/01</td> </tr> <tr> <td>⁽³⁾Temp [°C]</td> <td>⁽⁴⁾Zero [mV]</td> <td>⁽⁵⁾+510 [mV]</td> <td>⁽⁶⁾Comp [mV]</td> <td>⁽⁷⁾dZero [mV]</td> </tr> <tr> <td>-9.5</td> <td>18.5</td> <td>13.3</td> <td>-0.6</td> <td>0.2</td> </tr> <tr> <td>0.1</td> <td>18.7</td> <td>13.3</td> <td>-0.6</td> <td>0.2</td> </tr> <tr> <td>25.0</td> <td>19.1</td> <td>13.1</td> <td>-0.8</td> <td>0.0</td> </tr> <tr> <td>50.2</td> <td>19.8</td> <td>13.0</td> <td>-0.9</td> <td>-0.1</td> </tr> <tr> <td>79.9</td> <td>20.8</td> <td>12.9</td> <td>-1.1</td> <td>-0.2</td> </tr> <tr> <td colspan="5">----- L1</td> </tr> <tr> <td>COMP R1</td> <td>510 kOhm ⁽⁸⁾</td> <td>R3</td> <td colspan="2">56.0 Ohm ⁽⁸⁾</td> </tr> <tr> <td>RB</td> <td colspan="2">3482 Ohm ⁽⁹⁾</td> <td colspan="2"></td> </tr> <tr> <td>ZERO</td> <td colspan="2">-0.8 mV ⁽¹⁰⁾</td> <td>P_atm</td> <td>964 mbar</td> </tr> <tr> <td>SENS</td> <td colspan="4">16.41 mV/bar ⁽¹¹⁾</td> </tr> <tr> <td colspan="5">-----</td> </tr> <tr> <td>LIN ⁽¹²⁾ [bar]</td> <td>⁽¹³⁾ [mV]</td> <td>⁽¹⁴⁾ Lnorm [%Fs]</td> <td colspan="2">⁽¹⁵⁾ Lbfsl [%Fs]</td> </tr> <tr> <td>0.000</td> <td>0.0</td> <td>0.00</td> <td colspan="2">-0.01</td> </tr> <tr> <td>2.500</td> <td>41.1</td> <td>0.02</td> <td colspan="2">0.01</td> </tr> <tr> <td>5.000</td> <td>82.1</td> <td>0.00</td> <td colspan="2">0.00</td> </tr> <tr> <td>7.500</td> <td>123.1</td> <td>-0.02</td> <td colspan="2">-0.01</td> </tr> <tr> <td>10.000</td> <td>164.1</td> <td>-0.01</td> <td colspan="2">-0.01</td> </tr> <tr> <td colspan="5">-----</td> </tr> <tr> <td colspan="5">Long Term Stability Ok ⁽¹⁶⁾</td> </tr> <tr> <td colspan="5">Lot 72114-2 ⁽¹⁷⁾</td> </tr> <tr> <td colspan="5">Test 500 Volt Ok ⁽¹⁸⁾</td> </tr> <tr> <td colspan="5">Supply 1.000 mA ⁽¹⁹⁾</td> </tr> <tr> <td colspan="5">01.09.17 ⁽²⁰⁾ ----- GOL3.A03D1K ⁽²⁰⁾</td> </tr> </table>		----- 449					PA-10L / 10 bar / 10-1005-118 ⁽¹⁾		Sn I107547 ⁽²⁾			----- 29/01					⁽³⁾ Temp [°C]	⁽⁴⁾ Zero [mV]	⁽⁵⁾ +510 [mV]	⁽⁶⁾ Comp [mV]	⁽⁷⁾ dZero [mV]	-9.5	18.5	13.3	-0.6	0.2	0.1	18.7	13.3	-0.6	0.2	25.0	19.1	13.1	-0.8	0.0	50.2	19.8	13.0	-0.9	-0.1	79.9	20.8	12.9	-1.1	-0.2	----- L1					COMP R1	510 kOhm ⁽⁸⁾	R3	56.0 Ohm ⁽⁸⁾		RB	3482 Ohm ⁽⁹⁾				ZERO	-0.8 mV ⁽¹⁰⁾		P_atm	964 mbar	SENS	16.41 mV/bar ⁽¹¹⁾				-----					LIN ⁽¹²⁾ [bar]	⁽¹³⁾ [mV]	⁽¹⁴⁾ Lnorm [%Fs]	⁽¹⁵⁾ Lbfsl [%Fs]		0.000	0.0	0.00	-0.01		2.500	41.1	0.02	0.01		5.000	82.1	0.00	0.00		7.500	123.1	-0.02	-0.01		10.000	164.1	-0.01	-0.01		-----					Long Term Stability Ok ⁽¹⁶⁾					Lot 72114-2 ⁽¹⁷⁾					Test 500 Volt Ok ⁽¹⁸⁾					Supply 1.000 mA ⁽¹⁹⁾					01.09.17 ⁽²⁰⁾ ----- GOL3.A03D1K ⁽²⁰⁾					<ol style="list-style-type: none"> Type (PA-10L) and measuring range (10 bar) of pressure sensor Serial number of pressure sensor Actual test temperatures Uncompensated zero offset Zero offset values with compensation resistor R1 (+) or R2 (-) connected Zero offset with calculated compensation resistors connected Temperature zero error with compensation resistors connected Calculated compensation resistor values R1 or R2 (TCzero) and R3 or R4 (offset) RB: Bridge resistance at room temperature Calculated offset with compensation resistors R1 or R2 and R3 or R4 connected Sensitivity of pressure sensor at room temperature Pressure test points Signal at pressure test points Non-linearity (best straight line through zero) Non-linearity (best straight line) Results of long-term test Sensor traceability information Insulation test Excitation (constant current) Date of test ----- Test equipment 	
----- 449																																																																																																																																										
PA-10L / 10 bar / 10-1005-118 ⁽¹⁾		Sn I107547 ⁽²⁾																																																																																																																																								
----- 29/01																																																																																																																																										
⁽³⁾ Temp [°C]	⁽⁴⁾ Zero [mV]	⁽⁵⁾ +510 [mV]	⁽⁶⁾ Comp [mV]	⁽⁷⁾ dZero [mV]																																																																																																																																						
-9.5	18.5	13.3	-0.6	0.2																																																																																																																																						
0.1	18.7	13.3	-0.6	0.2																																																																																																																																						
25.0	19.1	13.1	-0.8	0.0																																																																																																																																						
50.2	19.8	13.0	-0.9	-0.1																																																																																																																																						
79.9	20.8	12.9	-1.1	-0.2																																																																																																																																						
----- L1																																																																																																																																										
COMP R1	510 kOhm ⁽⁸⁾	R3	56.0 Ohm ⁽⁸⁾																																																																																																																																							
RB	3482 Ohm ⁽⁹⁾																																																																																																																																									
ZERO	-0.8 mV ⁽¹⁰⁾		P_atm	964 mbar																																																																																																																																						
SENS	16.41 mV/bar ⁽¹¹⁾																																																																																																																																									

LIN ⁽¹²⁾ [bar]	⁽¹³⁾ [mV]	⁽¹⁴⁾ Lnorm [%Fs]	⁽¹⁵⁾ Lbfsl [%Fs]																																																																																																																																							
0.000	0.0	0.00	-0.01																																																																																																																																							
2.500	41.1	0.02	0.01																																																																																																																																							
5.000	82.1	0.00	0.00																																																																																																																																							
7.500	123.1	-0.02	-0.01																																																																																																																																							
10.000	164.1	-0.01	-0.01																																																																																																																																							

Long Term Stability Ok ⁽¹⁶⁾																																																																																																																																										
Lot 72114-2 ⁽¹⁷⁾																																																																																																																																										
Test 500 Volt Ok ⁽¹⁸⁾																																																																																																																																										
Supply 1.000 mA ⁽¹⁹⁾																																																																																																																																										
01.09.17 ⁽²⁰⁾ ----- GOL3.A03D1K ⁽²⁰⁾																																																																																																																																										

Notes

- The indicated specifications apply only for constant current supply of 1 mA. The sensor must not be supplied more than 3 mA. The output voltage is proportional to the current supply (excitation). If excitation other than 1mA used, the output signal will deviate from the calibrated values.
- If exposed to extreme temperatures, the compensation resistors should have a temperature coefficient of < 50 ppm/°C. Sensor and resistors can be exposed to different temperatures.
- Fine adjustment of zero with R5 potentiometer (20 Ω) is possible. In addition, a maximum TC-sensitivity can be guaranteed on request or the value for the compensation resistor (Rp) can be indicated. See Electrical Diagram of a PD-10L with Compensation on page 1.

Characteristic Lines

Examples of typical characteristic curves of the temperature coefficients, normalised at 25 °C, uncompensated vs. compensated

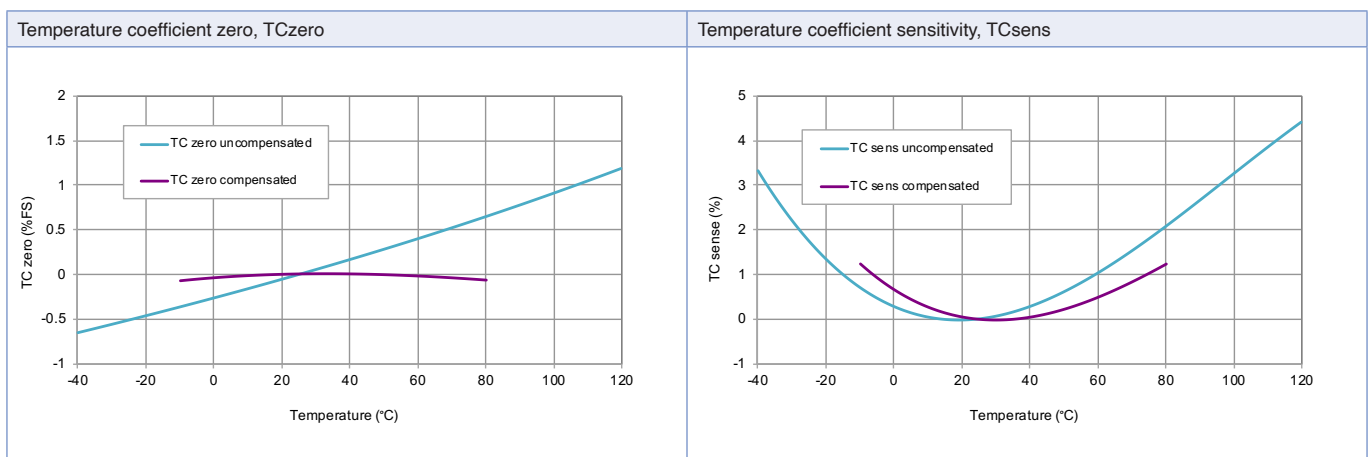

Whilst every effort has been made to ensure the accuracy of this specification, we cannot accept responsibility for damage, injury, loss or expense from errors or omissions. In the interest of technical improvement, this specification may be altered without notice.

For pricing or any further information, please contact Omni Instruments Ltd.

Series 10L – Analysis and Characteristic Lines

Mathematical Compensation Model

The KELLER pressure transducers of series 10L can be ordered with an optional mathematical compensation model.

The compensation model is a mathematical formula that helps to calculate the compensated pressure value of the pressure transducer.

Both the pressure signal and the temperature signal of the pressure transducer are incorporated into the calculation. Polynomial functions are used as the basis for this mathematical model.

The pressure transducers are characterised in the factory in order to produce the compensation model. This involves measuring pressure and temperature signals at various pressure and temperature levels. Comparing the measured values with the known pressure and temperature values enables the calculation of the compensation coefficients of the pressure transducer. These compensation coefficients are made available to the customer along with the respective pressure transducer.

Whilst every effort has been made to ensure the accuracy of this specification, we cannot accept responsibility for damage, injury, loss or expense from errors or omissions. In the interest of technical improvement, this specification may be altered without notice.

For pricing or any further information, please contact Omni Instruments Ltd.

Contact Details:

Tel: +44 1382 443000

Fax: +44 1382 453197

Email: info@omni.uk.com

Mailing Address: Unit 1, 14 Nobel Road,

Wester Gourdie Industrial Estate,

Dundee, DD2 4UH.

Website: www.omniinstruments.co.uk