

## DBCR Miniature S-Beam Load Cell

### Key Features:

- Capacities 0-5N to 0-500N
- Accuracy:  $\pm 0.05\%$  of Rated Capacity
- Sealed to IP50
- Robust Construction
- Compact Size
- 3 Year Warranty



### *For Tension and Compression Force/Load Measurement*

The DBCR series of low capacity S-beam load cells are designed for use in tension and compression force measurement and weighing applications alike. The DBCR is a compact version of the classic S-beam load cell and offers an accuracy of  $\pm 0.05\%$  of the rated capacity.

The DBCR 0-5N, 0-10N and 0-20N capacities are constructed of aluminium and the 0-50N to 0-500N are manufactured from 17-4PH stainless steel.

Typical applications include material test machines, component test rigs and general in-line force measurement. The DBCR can also be used in low capacity weighing applications, particularly with small suspended hoppers, where a slim, compact and accurate load cell is required.

### Options:

- Other Ranges Available on Request
- Spherical Rod End Bearings and Load Buttons
- Cable Lengths
- Shunt Calibration Facility
- Mounting Options
- Higher Accuracy Versions Available
- USB Version (via DSC-USB)
- High Temperature Versions
- Fatigue Rated Versions
- Vacuum Applications Versions
- Single or Multi-Channel PC-Based Monitoring & Data Logging System
- TEDS (Transducer Electronic Data Sheet)
- TEDS Allows Plug & Play with TEDS Enabled Instrumentation
- Wireless Version (via T24 instrumentation)

### Applications:

- Material Test Machines
- Component Test Rigs
- In-Line Force Measurements
- Low Capacity Weighing Applications
- Small Suspended Hoppers

Whilst every effort has been made to ensure the accuracy of this specification, we cannot accept responsibility for damage, injury, loss or expense from errors or omissions. In the interest of technical improvement, this specification may be altered without notice.





For pricing or any further information, please contact Omni Instruments Ltd.



## Specification:

<b>DBCR Miniature S-Beam Load Cell</b>		
Rated Capacity (RC)	N	0-5, 0-10, 0-20, 0-50, 0-100, 0-250, 0-500
Operating Modes	Tension/Compression / Tension & Compression	
Sensitivity (RO)	mV/V	2.0 ±0.1%
Zero Balance/Offset	±%/Rated Output	<1.0
Output Symmetry (tension vs. compression)	±%/Rated Output	<0.20
Non-Linearity	±%/Rated Output	<0.05
Hysteresis	%/Rated Output	<0.03
Repeatability	±%/Rated Output	<0.03
Temperature Effect on Zero	±%/Rated Output/ °C	<0.005
Temperature Effect on Sensitivity	±%/Applied Load/ °C	<0.005
Input Resistance	Ohms	375 nominal
Output Resistance	Ohms	350 nominal
Insulation Resistance	Megohms	>5000 @ 50Vdc
Excitation Voltage	Volts AC or DC	10 recommended (2-15 acceptable)
Operating Temperature Range	°C	-20 to +80
Compensated Temperature Range	°C	0 to +70
Storage Temperature Range	°C	-20 to +80
Safe Overload	% of Rated Capacity	150
Ultimate Overload	% of Rated Capacity	200
Deflection @ Rated Capacity	mm	
Fundamental Resonant Frequency*	Hz	5N=58, 10N=82; 20N=136; 50N=130; 100N=210; 250N=420; 500N=700
IP Rating (Environmental Protection)		IP50
Weight (excluding cable)	grams	5N to 20N = 85; 50N to 500N = 150
Fatigue Life		10 <sup>8</sup> cycles typical (10 <sup>9</sup> cycles on fatigue-rated version)
Cable Length (as standard)		2 Metres
Cable Type		4-core screened, PVC sheath, Ø3.5
Construction		5N-20N Aluminium Alloy, 50N-500N Stainless Steel
Resolution:		1 part in 250,000 (with appropriate instrumentation)

## Wiring Diagram:

Wire	Designation
 Red	+ve excitation
 Blue	-ve excitation
 Green	+ve signal
 Yellow	-ve signal
 Screen	To ground - not connected to load cell body

Whilst every effort has been made to ensure the accuracy of this specification, we cannot accept responsibility for damage, injury, loss or expense from errors or omissions. In the interest of technical improvement, this specification may be altered without notice.

For pricing or any further information, please contact Omni Instruments Ltd.

## Dimensions (mm):

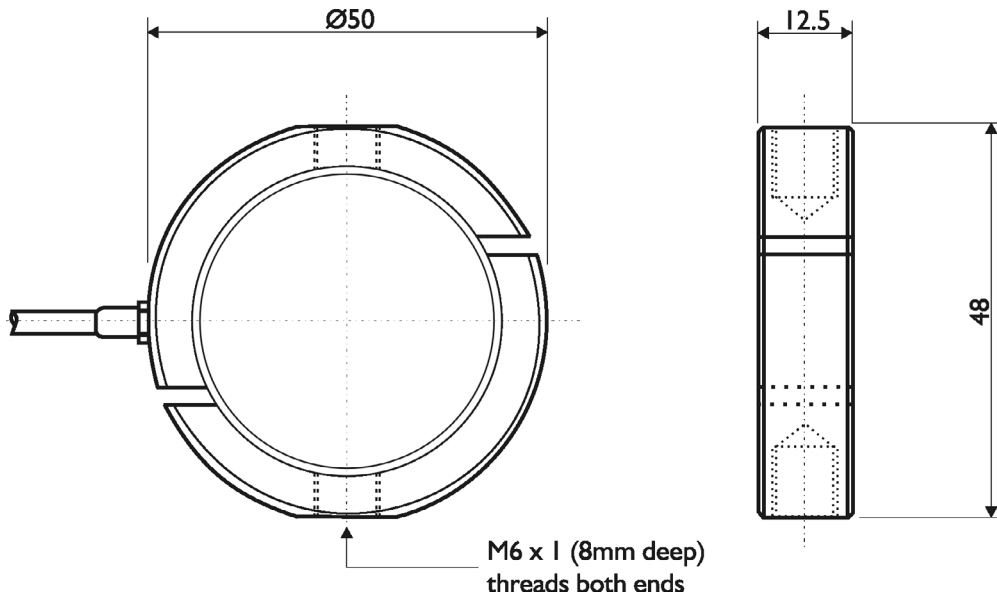

## Ordering Codes:

Core Product	Capacity (inc Engineering Units)	Cable Length (m)	Specials Code	Example Result
DBCR	5N	002	000	DBCR-5N-002-000
DBCR	10N	002	000	DBCR-10N-002-000
DBCR	20N	002	000	DBCR-20N-002-000
DBCR	50N	002	000	DBCR-50N-002-000
DBCR	100N	002	000	DBCR-100N-002-000
DBCR	250N	002	000	DBCR-250N-002-000
DBCR	500N	002	000	DBCR-500N-002-000

## Associated Products:



TR150 Handheld Indicator



T24 Wireless Telemetry Range



Intuitive4-L Panel-Mount Indicator



DSC-USB USB Signal Digitiser



ICA Miniature Strain Gauge Amplifier



SGA Signal Conditioner/Amplifier

For pricing or any further information, please contact Omni Instruments Ltd.



## Mounting and Installation Accessories:

*Helping You Get The Best Possible Performance From Your Load Cell.*

### Load Buttons and Rod End Bearings

Designed to align forces through the principle axis of the load cell thus reducing the effects of extraneous forces, hence offering improved performance from the cell.

Load buttons are used where compressive forces are applied.

Rod End Bearings are used where tensile forces are being applied.

## Dimensions in mm:

### Load Buttons for Compression Use

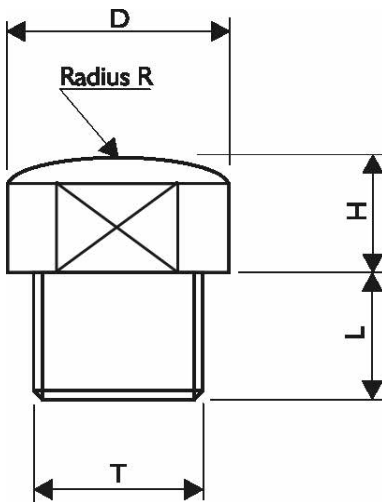

THREAD T	M6 x 1
D	12.5
H	6
L	9
R	200

### Rod End Bearings for Tension Use

Maintenance-free rod ends are a complete units made up of a housing with both an integral shank (with an internal or external thread) and a maintenance-free spherical plain bearing, located within the housing.

#### Key Features:

- Supports radial loads in a tensile or compressive direction.
- Suitable for unilateral loads - can support alternating loads and alternating loads in combination with bearing GE..UK-2RS, please consult sales.
- Zinc plated for corrosion resistance.
- Are maintenance-free.
- Fitted with radial spherical plain bearings GE..UK
- Hard chromium/PTFE composite sliding contact surfaces.
- Enables compact adjacent construction thanks to its thin walled design of the eye housing.

Whilst every effort has been made to ensure the accuracy of this specification, we cannot accept responsibility for damage, injury, loss or expense from errors or omissions. In the interest of technical improvement, this specification may be altered without notice.

For pricing or any further information, please contact Omni Instruments Ltd.

#### Contact Details:

Tel: +44 1382 443000

Fax: +44 1382 453197

Email: [info@omni.uk.com](mailto:info@omni.uk.com)

**Mailing Address:** Unit 1, 14 Nobel Road,  
Wester Gourdie Industrial Estate,  
Dundee, DD2 4UH.

**Website:** [www.omniinstruments.co.uk](http://www.omniinstruments.co.uk)



**GAR..UK**  
(right hand thread)

- To ISO 12 240-4, dimension series E, type M
- Shank with external thread

Maintenance-free  
ISO 12 240-4, dimension series E, type M  
Sliding contact surface: hard chromium/PTFE

Series GAR..UK  
Sliding material: PTFE composite

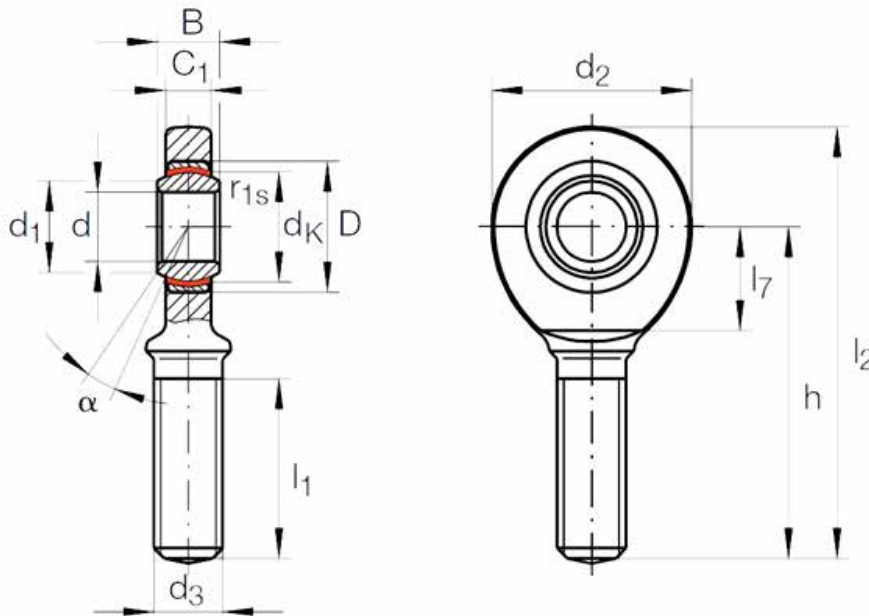

LOAD CELL	SHAFT DIAMETER	ORDERING CODE		MASS	DIMENSIONS						
		WITHOUT SEALS	WITH SEALS		≈ kg	d	D	B	dk	d <sub>1</sub>	d <sub>2</sub>
DBCR	6	GAR 6 UK	-	0.017	6 <sub>-0.008</sub>	14	6 <sub>-0.12</sub>	10	8	21	M6

LOAD CELL	h	C <sub>1</sub>	Degrees	l <sub>1</sub>	l <sub>2</sub>	l <sub>7</sub>	Chamfer Dimension	Basic Load Ratings		Radial Internal Clearance	Shaft Diameter
			α					dyn. Cr N	stat. C <sub>0r</sub> N		
DBCR	36	4.4	13	18	46.5	12	0.3	3 600	6 920	0 - 0.032	6

For pricing or any further information, please contact Omni Instruments Ltd.