

VFM60 VORTEX FLOW METER

DATASHEET

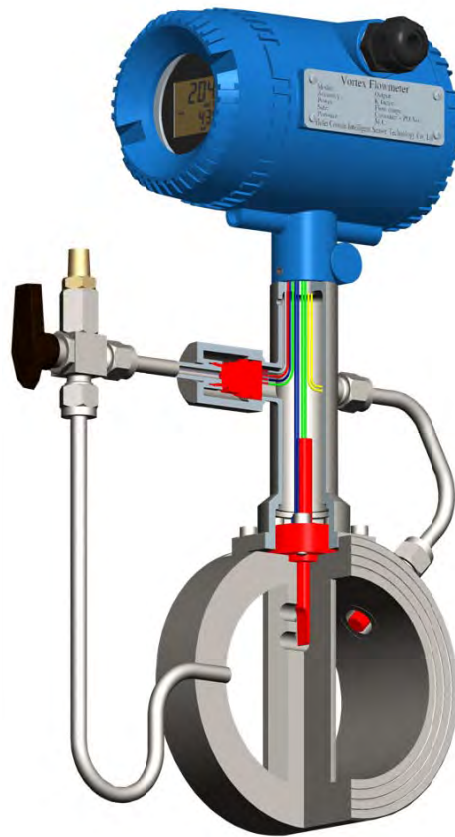

Whilst every effort has been made to ensure the accuracy of this specification, we cannot accept responsibility for damage, injury, loss or expense from errors or omissions. In the interest of technical improvement, this specification may be altered without notice.

For pricing or any further information, please contact Omni Instruments Ltd.

Contact Details:

Tel: +44 845 9000 601
Fax: +44 845 9000 602
Local Tel: 01382 443000
Email: info@omni.uk.com

Mailing Address:

Suite E, East Kingsway Business Centre,
Mid Craigie Trading Estate, Mid Craigie Road,
Dundee, DD4 7RH, UK

1. VFM60 Vortex Flow Meter



Wafer type

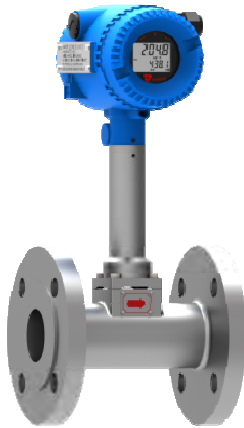

Flanged type



Insertion type

VFM60 is a powerful flow meter utilizing “Karman vortex” theory, which can meet the requirement of measuring the flow rate of various fluids such as gas, steam and liquid. The product uses the VFM60 transmitter technology, which provides with the excellent signal processing capability and enhance the vortex metering technology to a new level, which means it has lower measuring limit, better stability and accuracy. The unique dual-sensor design and special signal processing method has also ensured a better anti-vibration by eliminating the vibration signals to provide more reliable performance and lower measurement limit. The VFM60 platform is also an open platform, which means we can keep on upgrading its function according to customer’s unique requirement, and make the product a highly custom-orientation product.

- Sensor design that free from maintenance.
- Self density calculation function is optional, can calculate density and mass flow rate without mass flow computer. Can output mass flow rate, temperature and pressure by working with separate RTD and pressure transmitter
- Multi-variable version is optional, has built-in RTD and pressure sensor and can measure and display flow rate, velocity, temperature, pressure, mass flow rate and density.
- Unit selectable function, meet different requirement on reading’s units.
- DIN, DN, ANSI, JIS flange for option, can fit in any process connection.
- Many other options, such as 304SS and 316SS, insertion, wafer and flanged, different compensation method, different output methods. Customer can find the most suitable model to save cost.
- Self-diagnose function, ensure easier trouble-shooting
- Password can be set to protect setting model, easier for device management

- Blue tooth function optional, can read flow rate and other data on COMATE APP with and smart phone or pad.



Flanged and waferVFM60-MV Multi-variable Vortex Flow Meter

2. Specification

1) Process Fluids:

Used in liquid, gas, and steam applications. Fluids must be homogeneous and single-phase.

2) Line Sizes:

The wafer and flanged type cover line sizes as below.

1", 1.5", 2", 2.5", 3", 4", 5", 6", 8", 10", 12",

(DN25, DN40, DN50, DN65, DN80, DN100, DN125, DN150, DN200, DN250, DN300)

The insertion type covers DN200~1000.

Any requirement on other size, please check with our sales or engineers

3) Process connection:

Flanged, wafer, insertion. DN, ANSI, JIS, DIN Standard flanges are optional

4) Displayer:

Integral or remote. 3 buttons control. 2 lines LCD displayer.

1st line has 5 digits to display velocity, or mass flow or volume flow or frequency or temperature or pressure

2nd line has 8 digits to display total flow

A small extra line above 1st line will indicate what parameter being displayed in 1st line.

Note: The display can only display metric units, so when customer select Britain or US units, the display will show number only, but will not show the units



Display

5) Measureable parameter

Standard version: Volume flow rate in pipe, velocity (Can measure mass flow rate, temperature and pressure if wired to separate RTD and pressure transmitter.)

Multi-variable version: Mass flow rate, volume flow rate in standard condition, temperature, pressure, volume flow rate in pipe, velocity.

6) Measureable flow rate:

	Min Limit	Max Limit
Gas	6 m/s, DN15、 DN20	60 m/s
	4 m/s, DN25、 DN32	
	2 m/s, DN40~DN300	
Steam	6 m/s, DN15、 DN20	70 m/s
	4 m/s, DN25、 DN32	
	2 m/s, DN40~DN300	
Liquid	0.3 m/s	7 m/s

Note: The minimum limit above is for general usage. If customer needs to use the meter for low specific gravity or high viscosity liquid or gas, please provide detailed info of the fluid for us to calculate the accurate low limit

7) Accuracy:

Variables	For gas and steam	Liquid
Flow rate (m3/h)	±1%RD (Re ≥ 20000)	±0.75%RD (Re ≥ 20000)
	±2%RD (10000 < Re < 20000)	±2%RD (10000 < Re < 20000)
Mass flow (kg/h)	±1.5%RD(Re ≥ 20000)	±1.0%RD (Re ≥ 20000)
	±2.5%RD(10000 < Re < 20000)	±2.5%RD(10000 < Re < 20000)
Temperature(°C) (For multi-variable version)	±1°C	±1°C
Pressure(Mpa) (For multi-variable version)	±0.75% FS	±0.75% FS

8) Fluid temperature:

Standard: -40~150 degree C.

High temperature version: -40~250 degree C. (Not for insertion type version)

Expanded high temperature version: -40~350 degree C. (Not for insertion type and multi-variable version)

9) Pressure rating:

Standard pressure rating is 1.6Mpa. Optional pressure rating includes 2.5Mpa, 4Mpa, 6.3Mpa and 10 Mpa. For higher pressure, please contact us to check possibility

10) Output

- Pulse
- 4~20mA
- HART@4~20mA(the HART signal is on 4~20mA)
- M-BUS RS485

11) Explosive proof

Ex-proof version is optional. (Ex dII C T3 Gb from NEPSI)

ATEX, CSA, FM, IECEx proved enclosure are optional.

12) COMATE APP

Blue tooth function is optional to all COMATE products. Customers can read all data of the meter in COMATE APP on an cellphone or pad. The signal is valid within about 5 meters in front of the meter.

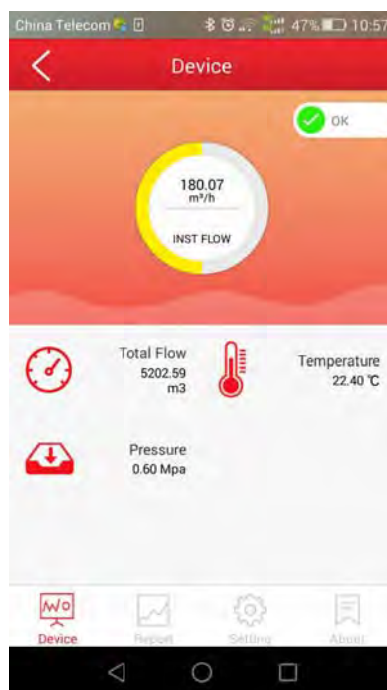

COMATE APP interface for VFM60MV

3. Dimension

1) Size and dimension for wafer type

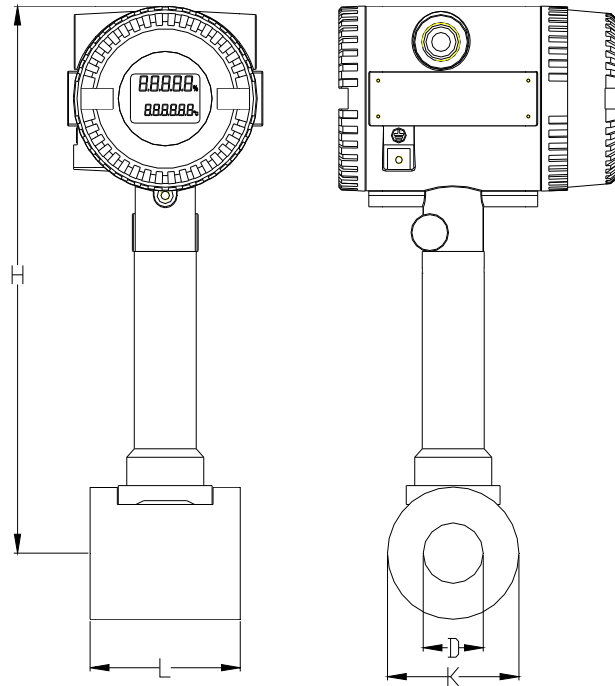

Size	K (Pipe O/D)	L(Pipe length)	W(Flange screw hole distance)	C(flange thickness)	m(screw hole diameter)	n(screw qty)	Meter height	Flange O/D
15	91	65	100	18	13	4	293.5	130
20	91	65	100	18	13	4	291	130
25	91	65	100	18	13	4	288.5	130
32	80	65	120	20	13	4	292.8	145
40	84	65	120	20	13	4	295.8	145
50	94	65	132	22	17	4	301	160
65	105	65	144	24	17	6	308.5	180
80	120	65	160	24	17	6	316	192
100	140	90	190	24	17	8	327	230
125	165	65	210	26	17	8	340.5	242
150	190	65	240	28	21	8	353	280
200	240	85	296	28	21	12	378	335
250	290	100	354	28	21	12	404	405
300	340	120	412	30	21	12	429	460

Remark: The flange O/D, screw holes distance, flange thickness, screw holes diameter and screw qty are for the counter flanges, unit in mm.

Counter flanges, screw and bolts, gaskets are usually along with package except customer do not need them.

2)Size and dimension for flanged type

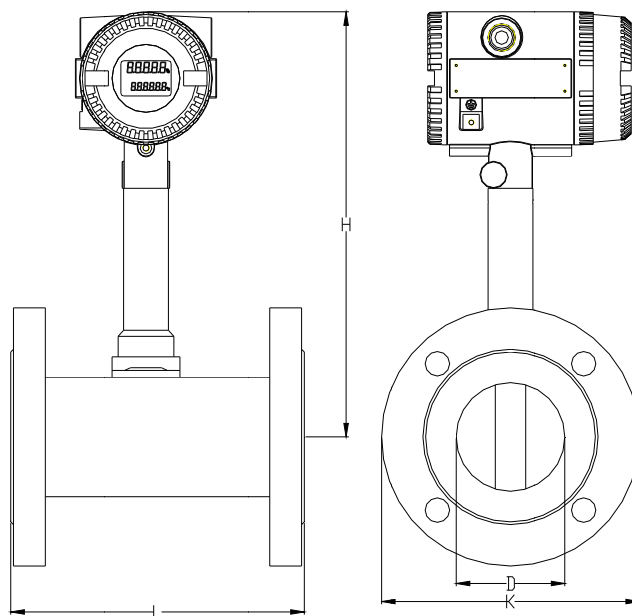

Dimension for ANSI RF150 Flanged

Size	K(Flange O/D)	L(Pipe length)	W(Flange screwhole distance)	C(flange thickness)	m(screwhole diameter)	n(screw qty)	Meter height
15	90	180	60.3	11.6	16	4	301.5
20	100	180	69.9	13.2	16	4	299
25	110	180	79.4	14.7	16	4	295.5
32	115	180	88.9	16.3	16	4	300.5
40	125	180	98.4	17.9	16	4	302.5
50	150	180	120.7	19.5	19	4	307
65	180	200	139.7	22.7	19	4	314
80	190	200	152.4	24.3	19	4	326
100	230	220	190.5	24.3	19	8	336
125	255	220	215.9	24.3	22	8	345
150	280	220	241.3	25.9	22	8	360
200	345	220	298.5	29	22	8	385
250	405	250	362	30.6	25	12	412.7
300	485	300	431.8	32.2	25	12	445.4

Remark:

Flanged version do not contains screws and bolts in the package unless customer need to purchase from us. We also have flanged type in other standard and pressure rating. Please check with us if you require flanged version other than ANSI RF150

3) Size and dimension for multi-variable wafer type

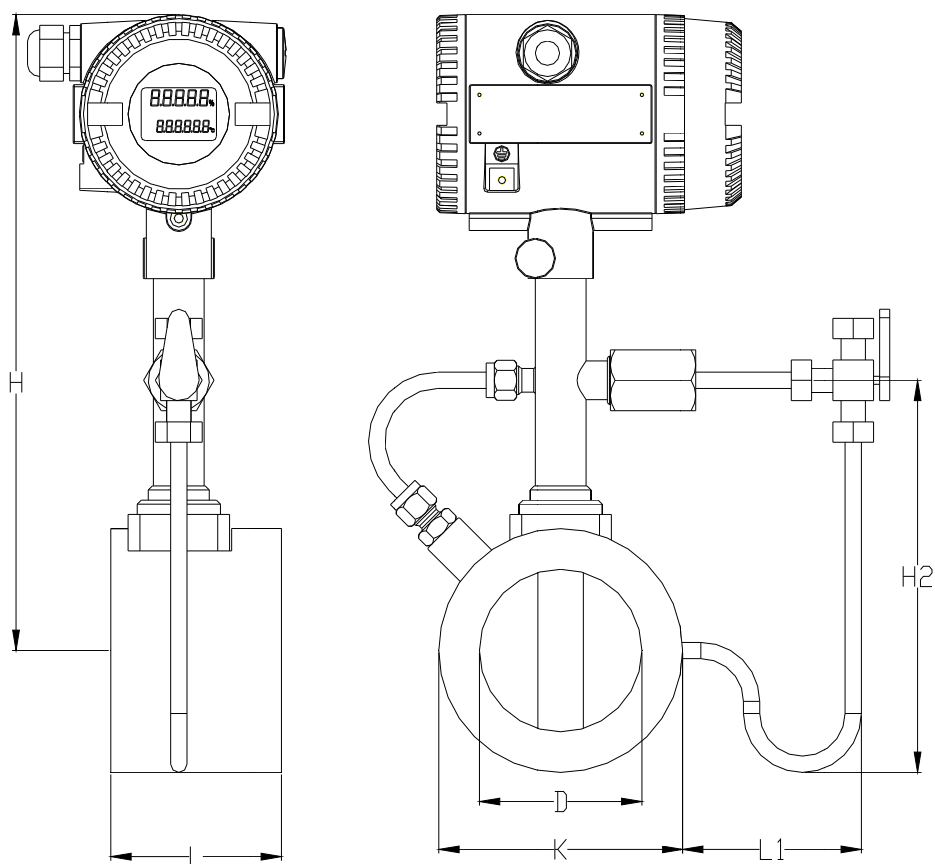

Wafer multi-variable type

Size	K (Pipe O/D)	Flange O/D	L(Pipe length)	W(Flange screw hole distance)	C(flange thickness)	M (screw hole diameter)	N (screw qty)	Meterr height	H2 (Condensation piep height)	L1(Condensation piep length)
15	91	130	65	100	18	13	4	293.5	151	140
20	91	130	65	100	18	13	4	291	148.5	137
25	91	130	65	100	18	13	4	288.5	146	136
32	80	145	65	120	20	13	4	292.8	152.8	133
40	84	145	65	120	20	13	4	295.8	157.8	129
50	94	160	65	132	22	17	4	301	168	124
65	105	180	65	144	24	17	6	308.5	181	116.5
80	120	192	65	160	24	17	6	316	206	109
100	140	230	90	190	24	17	8	327	217	99
125	165	242	65	210	26	17	8	340.5	243	99
150	190	280	65	240	28	21	8	353	268	99
200	240	335	85	296	28	21	12	378	318	99
250	290	405	100	354	28	21	12	404	369	99
300	340	460	120	412	30	21	12	429	419	99

4) Size and dimension for multi-variable flanged type

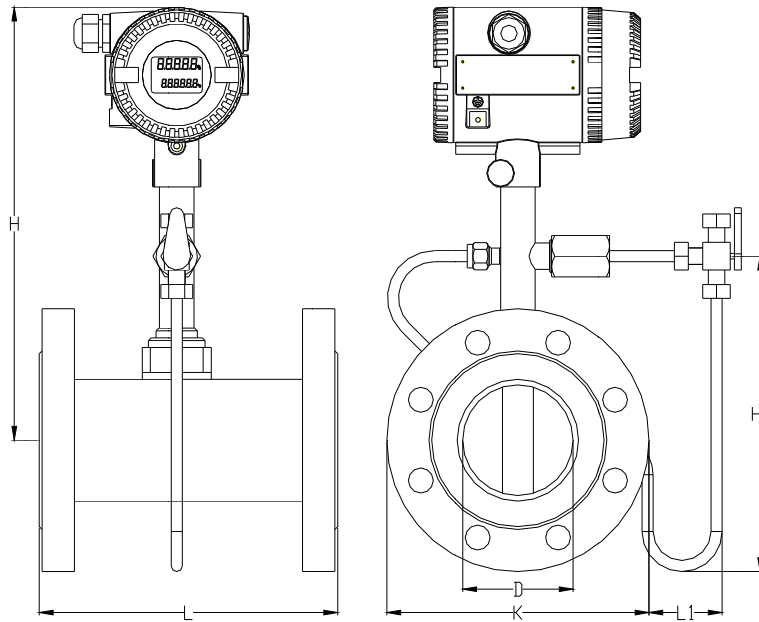

Flanged multi-variable type (ANSI RF150)

Size	K (Flange O/D)	L (Pipe length)	W (Flange screwhole distance)	C (flange thickness)	M (screwhole diameter)	N (screw qty)	Meter height	H2 (Condensation piep height)	L1 (Condensation piep length)
15	90	180	60.3	11.6	16	4	301.5	166.5	140
20	100	180	69.9	13.2	16	4	299	169	137
25	110	180	79.4	14.7	16	4	295.5	170.5	136
32	115	180	88.9	16.3	16	4	300.5	178	133
40	125	180	98.4	17.9	16	4	302.5	185	129
50	150	180	120.7	19.5	19	4	307	202	124
65	180	200	139.7	22.7	19	4	314	224	116.5
80	190	200	152.4	24.3	19	4	326	241	109
100	230	200	190.5	24.3	19	8	336	271	99
125	255	220	215.9	24.3	22	8	345	292.5	99
150	280	220	241.3	25.9	22	8	360	320	99
200	345	220	298.5	29	22	8	385	377.5	99
250	405	250	362	30.6	25	12	412.7	435.2	99
300	485	300	431.8	32.2	25	12	445.4	507.9	99

3) Insertion type

The insertion type size are according to customer's detail of applications

4. Ordering information

1) Mode number

The model number is usually VFM-1-23456789-XXX, please reference to the table below for what the model codes stand for.

Mode codes

1	General model	VFM60-N	Vortex flowmeter without integral RTD and pressure sensor	Standard	
		VFM60-MV	Vortex mass flowmeter with integral RTD and pressure sensor	Option	
2	Transmitter Location	T	Integral	Standard	Standard remote cable length is 5m, for longer cable, please let us know
		R	Remote	Option	
3	Process connection	0	Insertion	Option	Insertion for DN200~1000, wafer and flanged type for pipes smaller than 300mm
		1	Flanged	Standard	
		2	Wafer	Option	
		3	Downsized wafer	Option	
4	Fluid type	1	Liquid	Standard	If the fluid is steam, please advise if it is saturated or superheated
		2	Gas	Option	
		3	Steam	Option	
5	Wetted part material	1	OCr18Ni9(304)	Standard	For other materials, please advise your requirement.
		2	316	Option	
		Q	Other	Option	
6	Pressure rating	3	1.6 Mpa	Standard	
		4	2.5 Mpa	Option	
		5	4 Mpa	Option	
		6	6.3 Mpa	Option	
7	Medium Temperature	N	T≤150℃	Standard	If temperature is lower than 40 dgr C, please check with us. MV version max temperature is 250 dgr C
		S	T≤250℃ (wafer or flanged)	Option	
		H	T≤350℃ (wafer or flanged)	Option	
8	Transmitter	1	pulse/4~20mA	Standard	The HART signal is output though 4~20mA. MV stand for multi-variable version Option 2,4,6,8,9 require one week more for production
		2	pulse/HART@4~20mA	Option	
		3	Pulse/RS485	Option	
		4	pulse/ 4~20mA/RS485	Option	
		5	MV/pulse/4~20mA	Option	
		6	MV/pulse/HART@4~20mA	Option	
		7	MV/Pulse/RS485	Option	
		8	MV/pulse/ 4~20mA/RS485	Option	
		9	pulse/4~20mA/RS485/separate T&P	Option	
9	Blue tooth	Q	No Blue tooth	Standard	If need blue tooth, has to has RS485
		B	With blue tooth	Option	
10	Cable grinder	N	M20x1.5	Standard	
		Q	Other	Option	
	Pipe size	xxx	xxx		This 3 digits code indicates the inner diameter of the pipe, for example, 050 means DN50,

2) Other ordering information required

To ensure the customer find the right product which can fit in the application, it would be better if below information is provided with.

a. Detailed fluid introduction.

What is the fluid (air or steam or N2 or.....)? The viscosity and density of the fluid, the accurate process pressure and temperature ranges of the fluid are all very important. This information is required before we can know if our flow meter can be used in the fluid and what other treatment should be chosen

b. Flow rate.

As indicated in earlier section, you will find out velocity range in specification. If the flow range customer required is volume range (m³/hr, l/min) or mass flow rate (kg/hr, lb/hr, tons/day) ,we have to transfer them into velocity range. If the requirement of customer is a mass flow range, we have to calculate the density of the fluid base on the process pressure and temperature, than transfer it in to volume flow range and finally to velocity range

To know the process density of saturated steam, please reference to the appendix of density table of saturated steam.

c. If the fluid is O₂, the wetted parts have to be degreased .Also we can do the degreasing in our workshop, we strongly recommend customer to do it again at field before installation.

d. For wafer type, we will provide counter flanges which will be welded to the pipe during installation, thus customer should advise the material of the process pipe line. Our counter flanged will be made in the material same as the process pipe line to ensure a reliable welding.

e. For wafer type, we will provide customer along with screws and bolts for installation. But for flanged type, as all bolts and screws are standard parts, customer can prefer to buy them in local market to save the cost of transportation.

f. For flanged type, customers need to advise the type of the flanged.

g. If customer should have any other inquires or special requirements, please be free to check with our engineer or sales person.

3) Example of a model selection

Application:

Saturate steam, process pressure 0.8Mpa.

Flow rate:800~4000kg/hr

DN100 (4") ANSI flanged process connection.

RS485+PULSE output, 24VDC power, integral displayer

Counter ordering information

In 0.8Mpa, the density of saturated steam is about 4.162kg/hr (170 degree C)

800 kg/hr = 192 m3/hr = 6.8m/s

4000 kg/hr = 961 m3/hr = 34m/s

The velocity is within our standard measurement range of 2~70m/s

Counter solution:

Model number:VFM60-N-T1313S9N100 or VFM60-M-T1313S7N100

ANSI flange, 0.8Mpa saturated steam, 2~70 m/s, temperature compensation and RTD required or chose multi-variable version.

Appendix I. Specification chart

Fluid to measure	Liquid, steam, gas			
Nominal diameter	Wafer/Flanged(ANSI/DN/DIN/JIS):15mm~300mm(1/2"~12") Insertion:300mm~700mm(12"~28")			
Measurement range (m/s)		DN15~20	DN25~32	DN40~300
	Steam	6~70 m/s	4~70 m/s	2~70 m/s
	Gas	6~60 m/s	4~60 m/s	2~60 m/s
	Liquid	0.3~7m/s	0.3~7m/s	0.3~7m/s
Accuracy	±1% RD (insertion is 1.5%RD) For multi-variable version: temperature ±1℃,pressure:0.75% FS			
Repeatability	0.3% RD			
Output	Pulse / 4~20mA / 4-20mA@ HART / RS-485			
Process Temperature Range	-40℃~150℃ ; -40℃~250℃ ; -40℃~350℃ ;			
Process Pressure Limit	-0.1 MPa (-1 kg/cm2) to flange rating			
Ambient Temperature Range	-40 to 85℃			
Ambient Humidity	5 to 100% RH			
Electrical Connection	1/2 NPT, M20 × 1.5			
Materials	304 SS, 316 SS, 316L SS			

Appendix II. Density and measurement limits of saturated steam

Remark: All measurement limits is in unit Kg/hour, all pressure is absolute pressure

Pressure Mpa	0.3	0.4	0.5	0.6	0.7	0.8	0.9	1	1.2	1.5
Temperature °C	133.5	143.6	151.8	158.9	165	170.7	175.4	179.9	188	198.4
Density Kg/m ³	1.615	2.163	2.669	3.17	3.667	4.162	4.665	5.147	6.127	7.602
Lower limit DN25	22.8	30.6	37.7	44.8	51.8	58.8	65.9	72.7	86.5	107.4
Upper limit DN25	199.6	267.3	329.9	391.8	453.2	514.4	576.5	636.1	757.2	939.5
Lower limit DN32	18.7	25.0	30.9	36.7	42.4	48.2	54.0	59.6	70.9	88.0
Upper limit DN32	327.0	438.0	540.4	641.9	742.5	842.7	944.6	1042.2	1240.6	1539.3
Lower limit DN40	14.6	19.6	24.1	28.7	33.1	37.6	42.2	46.5	55.4	68.7
Upper limit DN40	511.0	684.3	844.4	1002.9	1160.2	1316.8	1475.9	1628.4	1938.5	2405.2
Lower limit DN50	22.8	30.6	37.7	44.8	51.8	58.8	65.9	72.7	86.5	107.4
Upper limit DN50	798.4	1069.3	1319.4	1567.1	1812.8	2057.5	2306.1	2544.4	3028.9	3758.1
Lower limit DN65	38.6	51.6	63.7	75.7	87.5	99.3	111.4	122.9	146.3	181.5
Upper limit DN65	1349.3	1807.1	2229.8	2648.4	3063.6	3477.2	3897.4	4300.1	5118.8	6351.1
Lower limit DN80	58.4	78.2	96.5	114.6	132.6	150.5	168.7	186.1	221.5	274.9
Upper limit DN80	2043.8	2737.4	3377.7	4011.8	4640.7	5267.2	5903.7	6513.7	7753.9	9620.6
Lower limit DN100	91.2	122.2	150.8	179.1	207.2	235.1	263.6	290.8	346.2	429.5
Upper limit DN100	3193.5	4277.1	5277.7	6268.4	7251.1	8229.9	9224.6	10177.7	12115.5	15032.2
Lower limit DN125	142.6	190.9	235.6	279.8	323.7	367.4	411.8	454.4	540.9	671.1
Upper limit DN125	4989.8	6683.0	8246.4	9794.3	11329.9	12859.3	14413.4	15902.6	18930.5	23487.8
Lower limit DN150	205.3	275.0	339.3	403.0	466.1	529.1	593.0	654.3	778.9	966.4
Upper limit DN150	7185.4	9623.5	11874.8	14103.8	16315.0	18517.4	20755.3	22899.8	27260.0	33822.5
Lower limit DN200	365.0	488.8	603.2	716.4	828.7	940.6	1054.2	1163.2	1384.6	1718.0
Upper limit DN200	12774.0	17108.5	21110.7	25073.4	29004.5	32919.8	36898.3	40710.7	48462.1	60128.8
Lower limit DN250	570.3	763.8	942.4	1119.4	1294.8	1469.6	1647.2	1817.4	2163.5	2684.3
Upper limit DN250	19959.4	26732.0	32985.5	39177.3	45319.6	51437.1	57653.6	63610.5	75722.1	93951.3
Lower limit DN300	821.2	1099.8	1357.1	1611.9	1864.6	2116.3	2372.0	2617.1	3115.4	3865.4
Upper limit DN300	28741.5	38494.1	47499.2	56415.3	65260.2	74069.5	83021.2	91599.2	109039.8	135289.8

Appendix III. Volume measurement limits of air.

Remark: All measurement limits is in unit m³/hour

Nominal size	DN25	DN32	DN40	DN50	DN65	DN80	DN100	DN125	DN150	DN200	DN250	DN300
Min flow (m ³ /hr)	14.1	11.6	9.0	14.1	23.9	36.2	56.5	88.3	127.1	226.0	353.1	508.5
Max flow (m ³ /hr)	105.9	173.6	271.2	423.7	716.1	1084.7	1694.9	2648.3	3813.6	6779.7	10593.2	15254.2

Appendix III. Volume measurement limits of liquidRemark: All measurement limits is in unit m³/hour

Nominal size	DN25	DN32	DN40	DN50	DN65	DN80	DN100	DN125	DN150	DN200	DN250	DN300
Min flow (m ³ /hr)	0.5	0.9	1.4	2.1	3.6	5.4	8.5	13.2	19.1	33.9	53.0	76.3
Max flow (m ³ /hr)	12.4	20.2	31.6	49.4	83.5	126.6	197.7	309.0	444.9	791.0	1235.9	1779.7

Contact information:

Omni Instruments Ltd
Suite E Ground Floor
East Kingsway Business Centre
Mid Craigie Trading Estate
Mid Craigie Road
Dundee DD4 7RH
Email: info@omni.uk.com
Web www.omniinstruments.co.uk
Telephone: +44 (0) 845 9000 601