

USB-AD14f

Data Acquisition System (USB)

Measurement & Control. Super-Low Priced.

Record and output signals with the USB-AD14f. The USB data acquisition system accommodated in a stable aluminum housing is ideal for medium-class applications impressing by universal applicability and an excellent price-performance-ratio.

16 Analog Inputs. 20kHz. 14 Bit. $\pm 10V$.

Voltage signals in the $\pm 10V$ range are connected at 16 analog inputs. Sampling is done with 14 bit resolution and 20kHz total sampling rate.

1 Analog Output. 12 Bit. $\pm 5V$.

The 5V output can be used for analog control with 12 bit accuracy.

8 Digital IN. 8 Digital OUT. 1 Counter.

Digital states are recorded or set at eight digital inputs and outputs each. Digital inputs are sampled time-synchronously with the analog inputs. The USB-AD14f features a 16-bit counter for the acquisition of counting pulses.

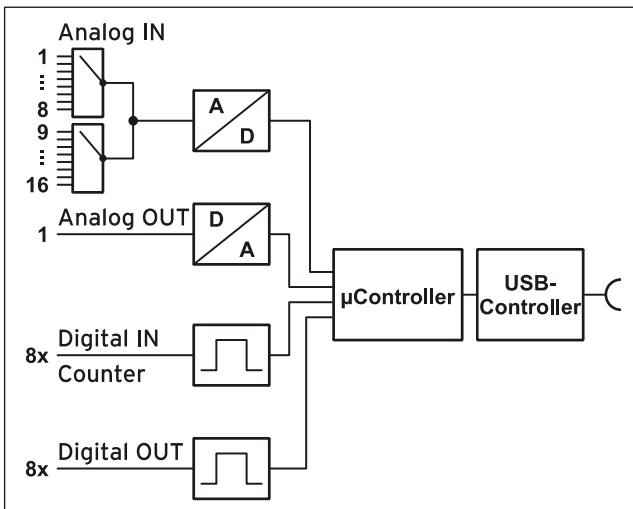

Functional diagram



Plug & Play.

The connection to the PC is realized via USB. The USB-AD14f provides all typical USB features (e.g. Plug&Play, Hot-Plug). Up to 127 devices can be connected and installed during operation.

Powered by USB.

The device is supplied with power via the USB interface. This reduces cabling efforts to a minimum and makes mobile measurements a lot easier.

Open for Everyone.

Widely supported: The data acquisition system can be used under Windows[®] XP/7/8/10 as well as under Mac OS X, Free BSD, and Linux. The complete software for installation and programming of the USB-AD14f is included for free.



NextView[®]4. Try for Free.

The DAQ system is supported by NextView[®] 4, the software for data acquisition and analysis. A fully functional 30-day trial is included with delivery to directly test the functionality of the USB-AD14f.

Accessory. Makes Everything so Easy.

Use the demo board ZU-DBD featuring various operating controls and sensors to generate 16 analog signals and record them with the USB data acquisition system.

For pricing or any further information, please contact Omni Instruments Ltd.

1 Start-up Procedure

Install the bmc driver package (see chapter 5.1.1). Plug the red frames onto the short sides of the device with the feet looking downward as to be seen in the product picture. Connect one end of the USB cable to the device and the other to the USB-interface of the PC and start the Plug&Play installation (see chapter 5.1.2). The device is supplied with power via the USB-connection.

If necessary, further software components can be installed now, as described in chapter 5.

2 Analog Inputs and Outputs

The 37-pin D-Sub female connector at the front of the device is designed for the connection of the analog inputs and outputs. An auxiliary voltage (e.g. for sensor supply) is provided at pin 17.

The following table shows the pin assignment of the 37-pin D-Sub connector:

D-Sub 37	Assignment	D-Sub 37	Assignment
1	AIn 1	11	AIn 11
2	AIn 2	12	AIn 12
3	AIn 3	13	AIn 13
4	AIn 4	14	AIn 14
5	AIn 5	15	AIn 15
6	AIn 6	16	AIn 16
7	AIn 7	17	V _{USB} (4-5V; max. 20mA)
8	AIn 8	18	AOut 1
9	AIn 9	19	n. c.
10	AIn 10	20..37	AGND

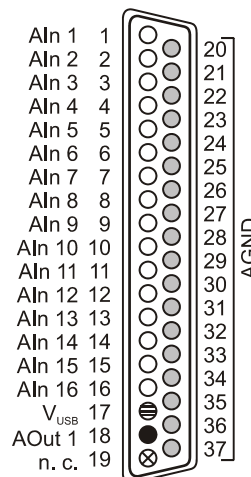

- AIn = Analogeingang / analog input
- AOut = Analogausgang / analog output
- AGND = analoge Masse / analog ground
- ⊖ V_{USB} = Hilfsspannung / auxiliary voltage
- ⊗ n. c. = nicht verbunden / not connected



The max. potentials to ground must not exceed ±12V. Any channel overload may influence measurements of other channels and may lead to wrong values.

The internal connection of the 16 analog inputs is provided via a 40-way pin connector P5 (see figure on the right, here: current measurement at channel 2) on the USB-AD14f board, which for example can be used to connect current shunts (ZU-CS250R available as accessory).

The following table shows the pin assignment of the 40-way pin connector:

Pin	Assignment	Pin	Assignment
1	AIn 1	17	AIn 9
3	AIn 2	19	AIn 10
5	AIn 3	21	AIn 11
7	AIn 4	23	AIn 12
9	AIn 5	25	AIn 13
11	AIn 6	27	AIn 14
13	AIn 7	29	AIn 15
15	AIn 8	31	AIn 16
2, 4, ..., 30, 32	AGND	33, 34, ..., 39, 40	n. c.

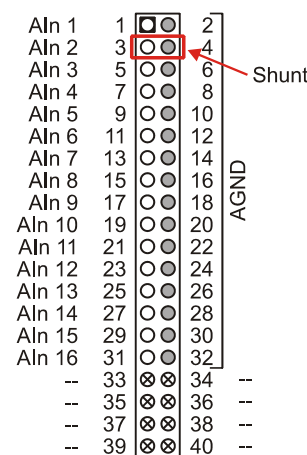
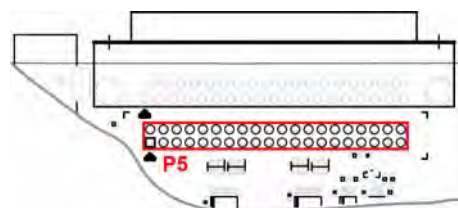

- AIn = Analogeingang / analog input
- AGND = analoge Masse / analog ground
- ⊗ -- = interne Verwendung / internal use

3 Digital Inputs and Outputs

The USB-AD14f features 4 digital inputs and outputs each (*low*: 0V..0.7V; *high*: 3V..5V). A 16-bit counter is available at pin 9.

All connections are led to the 25-pin D-Sub female connector on the back of the device. The pin assignment is as follows:

D-Sub 25	Assignment
5	DIn 1
18	DIn 2
6	DIn 3
19	DIn 4
7	DIn 5
20	DIn 6
8	DIn 7
21	DIn 8
9	counter (0..5V, 100kHz)
13	DGND

D-Sub 25	Assignment
1	DOut 1
14	DOut 2
2	DOut 3
15	DOut 4
3	DOut 5
16	DOut 6
4	DOut 7
17	DOut 8
9, 10, 11, 12, 22, 23, 24, 25	n. c.

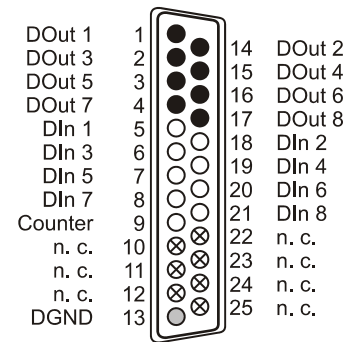

- DOut = Digitalausgang / digital output
- DGND = digitale Masse / digital ground
- ⊗ n. c. = nicht verbunden / not connected
- DIn = Digitaleingang / digital input
- Counter = Zählereingang / counter input



- The digital lines are protected by resistors. If the input voltage is not within the permitted voltage range of 0V..5V, the device may be damaged.
- The digital ground (DGND) is connected with the PC ground.

4 Interfacing Examples for the Digital Lines of the USB-AD14f

The following basic connection examples demonstrate the use of the digital inputs and outputs and the connection of a counter to the USB-AD14f. The pin assignment of the 25-pin D-Sub female connector is described in chapter 3.

4.1 Interfacing Examples for Digital Inputs

The 3.9kΩ pull-down resistor sets the input to *low* if no voltage is applied there.

4.1.1 Connecting an Optocoupler

Optocouplers provide optimum protection at each input line. With them, it is possible to connect higher voltages and to protect the hardware from being destroyed.

In this regard, please also see application examples of the optocoupler you use.



Optocoupler cards featuring 8 inputs are available.

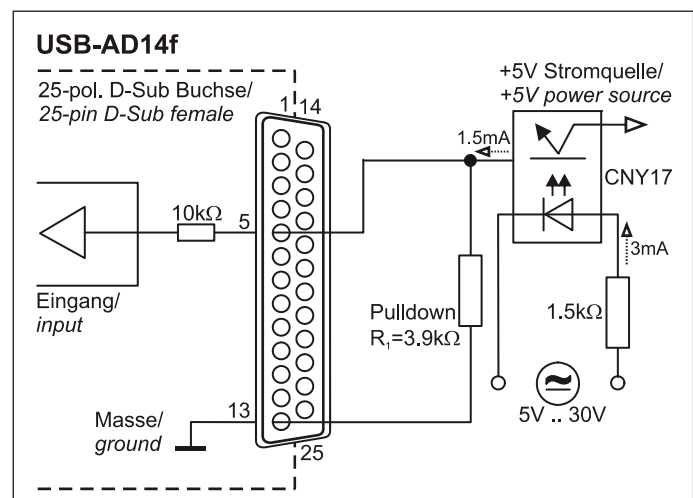

4.1.2 Connecting a Push-Button / Switch

Please make sure to use a push-button with debounce protection, because otherwise several pulses might be recorded.

The 3.9kΩ pull-down resistor is absolutely necessary to create a defined low signal!

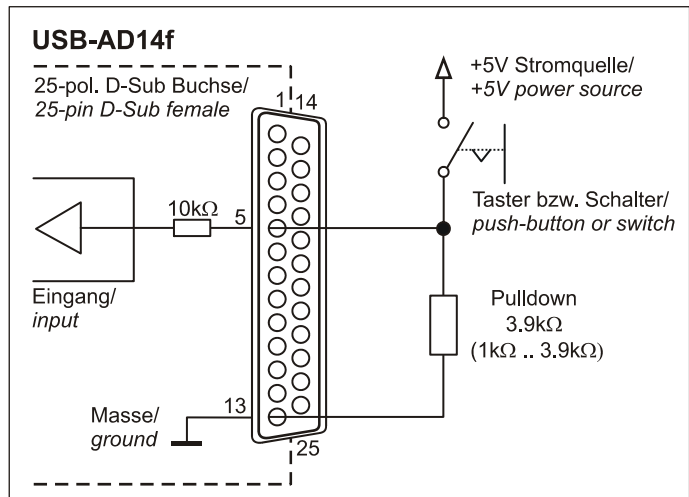

4.1.3 Connecting a Voltage Divider

If connecting a DC voltage higher than 5V, a voltage divider must be used so that 5V at the maximum are applied at the device input. Exceeding the 5V input voltage might cause damages to the device.

The relation between the two resistors to be used is calculated with the following formula:

$$U/U_1 = (R_1 + R_2) / R_1$$

Input voltages less than 5V are also sufficient ($high \geq 3V$).

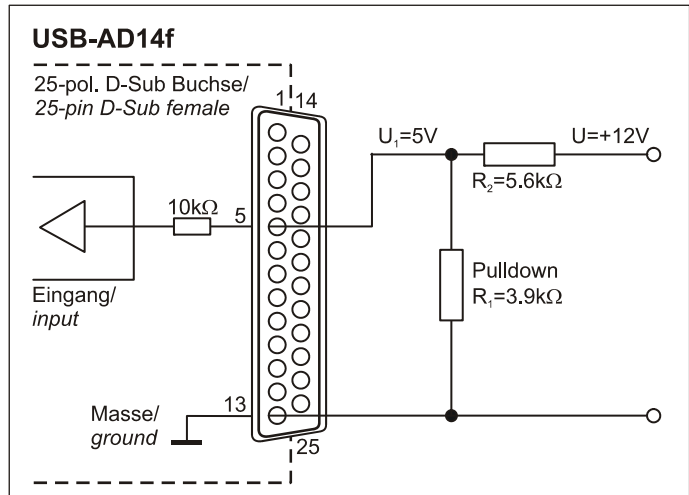

4.1.4 Connecting a Counter

The 16-bit counter is available at Pin 9 of the 37-pin D-Sub connector.

At maximum performance ($2^{16}-1$), the counter is reset and starts from zero again.

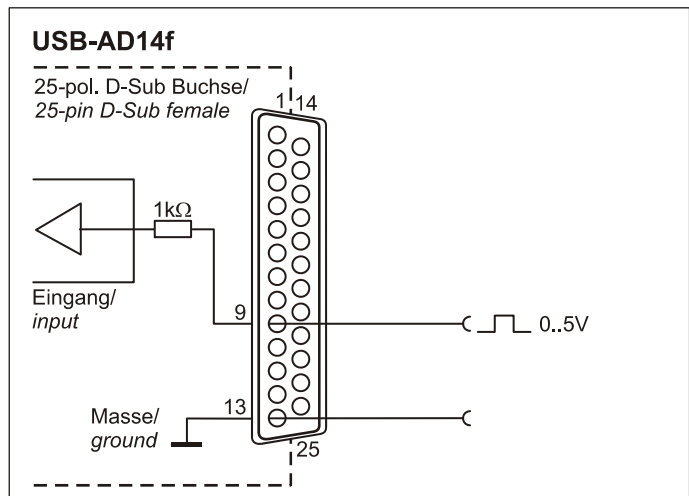

4.2 Interfacing Examples for Digital Outputs

Serial resistors in the output lines limit the current and protect the hardware from being destroyed.

4.2.1 Connecting an LED

Only so-called low-current LEDs can be used, because they already work with 1mA current.

Please also observe the total current listed in the technical data (see chapter 7).

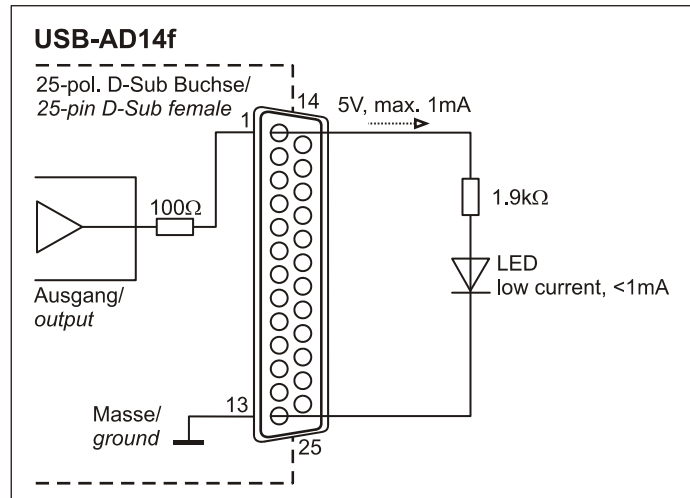

4.2.2 Connecting a Relay

A connected relay is ideal to switch higher currents. Since the field coil of the relay requires a higher current than provided by the measurement system at one line, a transistor is connected ahead.



Relay cards featuring 8 outputs are available.

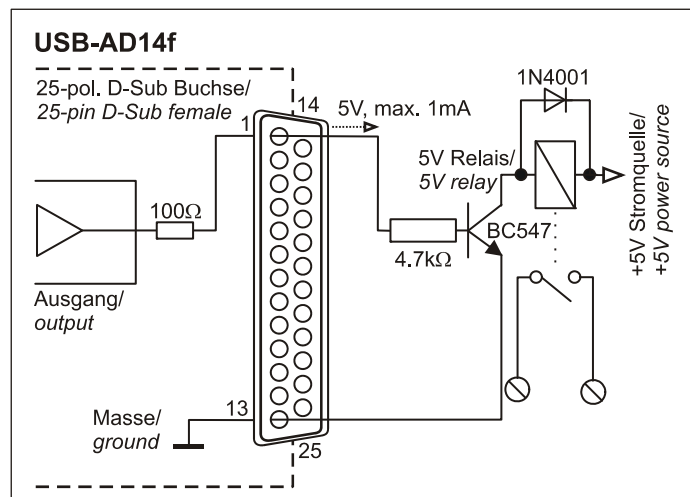

4.2.3 Connecting a Lamp

A transistor can be used to switch higher loads. The selected transistor must comply with the maximum switchable current.

The figure on the right shows an application with a maximum current of 100mA.

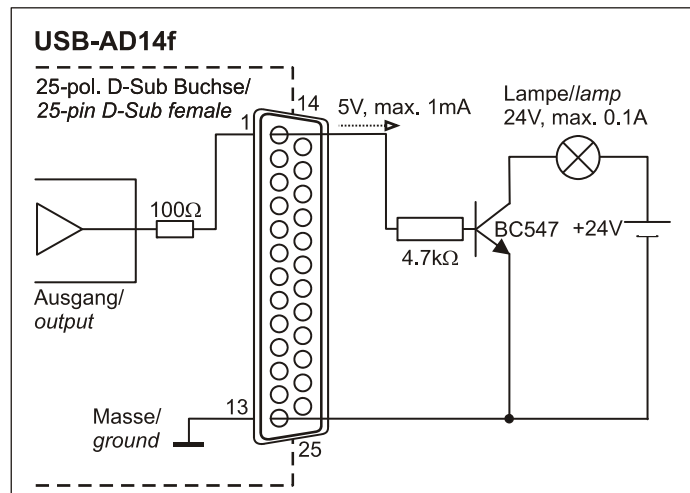

5 Software Installation



All software and documentation available for the USB-AD14f are integrated on the "Software Collection" CD included with delivery. When inserting the CD, a CD starter opens automatically (otherwise: start **openhtml.exe**).



USB-AD14f

Change to the product page of the USB-AD14f by selecting the entry "Products" in the CD starter and then the hardware ("USB-AD14f") listed under the interface "USB".



For detailed information about installing or operating the software, please see the corresponding manuals. The Adobe Acrobat Reader is required to open the documentation in PDF format.



You can run the installation directly from CD. If your browser prevents this, first save the setup program to hard disc before running it separately.

Software	Software product	Notes	Documentation
Device driver	BMCM-DR (driver package)	1. install driver package to hard disc 2. Windows® Plug&Play installation	IG-BMCM-DR (driver installation manual)
Program- ming	STR-LIBADX	ActiveX control for hardware independent programming	IG-LIBADX (installation / programming manual)
	STR-LIBADX-EX	example programs for LIBADX ActiveX control	-
	SDK-LIBAD	SDK with example programs for C/C++ on Windows®, Mac OS X, FreeBSD, Linux	UM-LIBAD4 (installation / programming manual)
Operating program	NV4.6	measuring software NextView®4 available in the Standalone versions: <ul style="list-style-type: none"> • Lite: "slim" version with basic functions • Pro: full version with complete functional range • Analysis: version for the analysis of stored measuring data <p>NextView®4 can be used for free as a fully functional 30-day trial version. After purchasing the software, all projects, measurement files, and settings can still be used.</p>	DS-NV4 (data sheet) UM-NV4 (user manual) "First steps" in the NextView®4 demo project (displayed when first starting the software)

5.1 Driver Installation



Under Windows®, the driver installation is always required for the USB-AD14f. Only then additional software can be installed. To make sure the installation is done correctly, please follow the instructions in the order as described below.



Under Mac OS X, FreeBSD and Linux, driver installation is not necessary.

5.1.1 Install Driver Package

The prior installation of the bmcm driver package [BMCM-DR](#) to the hard disc of your PC makes the driver search for Windows® much easier. Especially in case of driver updates, only the new driver package has to be installed, the hardware automatically uses the new version.

The link to install the driver package is located on the USB-AD14f product page of the "Software Collection" CD.

5.1.2 Plug&Play Installation

As soon as the device is connected to the PC, the system announces the new hardware. Since the driver package has been copied to hard disc before, the hardware will be installed automatically under Windows[®] 7/8/10. Under Windows[®] XP, the automatic hardware detection is started by selecting the following:



- Windows[®] 7/8/10: no specifications required
- Windows[®] XP: "Install the software automatically" (SP2: do not connect with Windows[®] Update!)

5.1.3 Check Installation

The entry "Data Acquisition (BMC Messsysteme GmbH)" is included in the Windows[®] Device Manager after successful installation displaying the installed bmc hardware. To open the Device Manager, proceed as follows:



- Windows[®] 7: Start / Control Panel / System and Security / System / Device Manager
- Windows[®] 8/10: Right-click screen corner bottom left (keyboard "Windows+X") / Device Manager
- Windows[®] XP: Start / Control Panel / System / TAB "Hardware" / button "Device Manager"

Double click the "USB-AD14f" to show the properties of the USB data acquisition system. For general information, existing device conflicts and possible sources of error, see TAB "General".

5.2 Programming

Programming the USB-AD14f with Visual Basic[®], Delphi[®], Visual C++[™] under Windows[®] XP/7/8/10 is possible with the hardware independent [STR-LIBADX](#). It is available on the USB-AD14f product page of the "Software Collection" CD. After installation, the ActiveX control must be loaded into the respective programming environment.



- Visual Basic[®]: menu "Project / Components", entry "LIBADX Object Library 4.0"
- Delphi[®]: menu "Components / Import ActiveX", entry "LIBADX Object Library 4.0"

If you select the entry [STR-LIBADX-EX](#), you can install example programs (with source code) demonstrating how to apply the ActiveX control.



Programming the USB-AD14f under Mac OS X and Unix (FreeBSD, Linux) with C/C++ is done by means of the LIBAD4 programming interface.

The [SDK-LIBAD](#) for the respective operating system (also Windows[®]) is included on the product page of the USB-AD14f. For further information about how to integrate the SDK in the programming environment, please see the corresponding programming manual [UM-LIBAD4](#).

5.3 Using USB-AD14f with NextView[®]4

Install the fully functional trial of the professional software NextView[®]4 for measurement data acquisition and processing to directly test the features and functions of the USB-AD14f.



The setup program [NV4.6](#) is available on the product page of the card. When first starting the software, request a license number with the option "Request 30 days free trial version" being checked and select your DAQ system (USB-AD14f) in the following dialog "Device Setup".

The start project of NextView[®]4 contains first instructions about how to operate the program. For detailed information, an online help is provided.



The trial is valid for 30 days after requesting the license number. If a license is not purchased within this period, the functional range of NextView[®]4 will be considerably cut down!

6 Important Notes for Using the USB-AD14f

- The device is only suitable for extra-low voltages - please observe the relevant regulations! Only use the device with housing closed. ESD voltages at open lines may cause malfunction.
- Only use non-solvent detergents for cleaning. The product is designed to be maintenance-free.
- Signal cables are connected at the 37-pin or 25-pin D-Sub female connector – preferably use shielded cables. For best possible interference suppression, connect shield at one end only. Close open inputs if necessary.
- The device ground and the chassis are electrically connected to the chassis of the PC, which is usually also connected to ground. Be sure to avoid ground loops since they will cause measuring errors!
- PCs (notebooks) which are not grounded often produce high potentials to earth at the USB socket so that safe operation cannot be guaranteed. In this case, connect the measuring system to earth.
- The gain is adjusted to even values. Therefore, only 16000 values (for 14 bit) of the full range of the converter are used. As a result, the measuring ranges are slightly larger (e.g. $\pm 10.24V$) than the indicated measuring ranges so that overranges can be recognized. The AD converter of the USB-AD14f has a code noise of up to ± 2 LSB.
- The device must not be used for safety-relevant tasks. With the use of the product, the customer becomes manufacturer by law and is therefore fully responsible for the proper installation and use of the product. In the case of improper use and/or unauthorized interference, our warranty ceases and any warranty claim is excluded.



Do not dispose of the product in the domestic waste or at any waste collection places. It has to be either duly disposed according to the WEEE directive or can be returned to bmcM at your own expense.

7 Technical Data

(typical at 20°C, after 5min., +5V supply)

• Analog Inputs

Channels // Resolution // Sampling rate:	16 single-ended // 14 bit (1.2mV) // max. 20kHz total sampling rate*
Measuring range // Accuracy // Noise:	$\pm 10V$ // $\pm 3mV$ // ± 2 LSB
Surge protection:	max. $\pm 35V$ (when turned on), $\pm 20V$ (when turned off), max. $\pm 20mA$ in total of all input channels!
Input resistance // Input capacity:	$1M\Omega$ (with PC turned off: $1k\Omega$) // $5pF$
Zero shift // Gain drop:	$\pm 50ppm/^\circ C$ // $\pm 50ppm/^\circ C$
Frequency accuracy // Frequency drift:	max. $\pm 50ppm$ // max. $\pm 50ppm/^\circ C$

* The total sampling rate is the sum of the sampling rates of the individual used channels (e.g. if 4 channels are scanned with 5kHz, the total sampling rate adds up to 20kHz).

• Analog Outputs

Voltage range // Output current:	1 voltage output with $\pm 5V$ // 1mA max.
Resolution // Accuracy:	12 bit // typ. ± 4 LSB, max. ± 8 LSB
Zero shift // Gain drop:	$\pm 50ppm/^\circ C$ // $\pm 50ppm/^\circ C$

• Digital Inputs/Outputs

Channels // Level:	8 input and 8 output channels // CMOS/TTL compatible (low: $0V..0.7V$; high: $3V..5V$)
Current pick-up per output pin:	1mA (with app. 4V level), max. 2.5mA (with app. 3V level)
Surge protection:	max. $\pm 5.5V$, protected with $1k\Omega$, max. max. $\pm 20mA$ in total of all channels!
Counter:	100kHz, 16 bit, $0..5V$ input voltage

• General Data

Power supply:	$+4.5V..+5.5V$ from USB connection to the PC, max. 100mA
USB interface:	USB 2.0 compatible (full speed)
Connections analog:	all channels at a 37-pin D-Sub female at the device front
Connections digital:	all channels at a 25-pin D-Sub female at the device back
CE standards:	EN61000-6-1, EN61000-6-3, EN61010-1; for decl. of conformity (PDF) visit www.bmcM.de
ElektroG // ear registration:	RoHS and WEEE compliant // WEEE Reg.-No. DE75472248
Max. permissible potentials:	60V DC acc. to VDE , max. 1kV ESD on open lines
Temperature ranges // Relative humidity:	operating temp. $0..70^\circ C$, storage temp. $-25..+85^\circ C$ // 0-90% (not condensing)
Dimensions // Protection type:	$167 \times 113 \times 30 \text{ mm}^3$ // IP30
Delivery:	device in aluminum housing, 1m USB connection cable, "Software Collection" CD, description
Available accessories (optional):	demo board ZU-DBD, DIN rail set ZU-SCHI, current shunt ZU-CS250R, connecting cables ZUKA25, ZUKA37SB, ZUKA37SS, 37-pin D-Sub plugs ZU37ST, ZU25ST, connector boards ZU37BB/CB/CO, waterproof housing ZU-PBOX-PG
Warranty:	2 years from date of purchase at bmcM, claims for damages resulting from improper use excluded

• Software

Software on CD (included):	ActiveX Controls LIBADX (hardware independent) for programming on Windows® XP/7/8/10, LIBAD4 SDK for C/C++ programming on Windows® XP/7/8/10, Mac OS X, Unix (FreeBSD, Linux); trial version of the measuring software NextView®4 to test and operate the hardware
NextView®4 (optional):	professional software (versions: Professional, Lite) for the acquisition and analysis of measurement data on Windows® XP/7/8/10

Manufacturer: BMC Messsysteme GmbH. Subject to change due to technical improvements. Errors and printing errors excepted. Rev. 1.0 05/16/2018