



IO-RMA

Adjustable Relay Module



Features:

- Adjustable switching point of relay
- On/Off/Auto links for ease of commissioning
- 8A relay and 0-10Vdc output
- DIN Rail mounting

Benefits:

- Fault finding LED indication
- Relay status LED indication

Technical Overview

The IO-RMA accepts a 0-10Vdc signal and provides a relay output with a adjustable switching threshold. The LED indicates that the relay is energised and Hand/Off/Auto jumpers ease commissioning.

The IO-RMA is ideal for any application where the switching of plant is interlocked with modulation of the same, or a different item of plant. Using the IO-RMA saves an output on the BMS controller.

For pricing or any further information, please contact Omni Instruments Ltd.

Contact Details:

Tel: +44 845 9000 601
Fax: +44 845 9000 602
Local Tel: 01382 443000
Email: info@omni.uk.com

Mailing Address:

Suite E, East Kingsway Business Centre,
Mid Craigie Trading Estate, Mid Craigie Road,
Dundee, DD4 7RH, UK



Specification:

Input signal	0-10Vdc 1mA min. into 22kΩ impedance
Output contacts:	
Relay	8A at 230Vac (resistive load)
Voltage	0-10Vdc
Power supply:	
	24Vac ±15% @ 50Hz or 24Vdc +15% -6%, 65mA max.
LED indication:	
	Supply OK Supply voltage low Supply voltage high Relay Status Hi input voltage
Manual override	On/Off/Auto jumper selectable
Electrical terminals	Rising cage connectors for 0.5-2.5mm ² cables
Ambient range:	
Temperature	-10 to +40°C (14 to 107°F)
RH	0-80% non-condensing
Dimensions (H x W x H)	72 x 49.5 x 55 (2.83 x 1.95 x 2.17")
Country of origin	UK

Part Codes:

IO-RMA
Adjustable relay module



The products referred to in this data sheet meet the requirements of EU 2004/108/EC and 2006/95/EC



Warning!

When installed, the output relay contacts may carry 240Vac. Special care must be taken to isolate the switched voltages prior to any work being undertaken.

For pricing or any further information, please contact Omni Instruments Ltd.

Contact Details:

Tel: +44 845 9000 601
Fax: +44 845 9000 602
Local Tel: 01382 443000
Email: info@omni.uk.com

Mailing Address:

Suite E, East Kingsway Business Centre,
Mid Craigie Trading Estate, Mid Craigie Road,
Dundee, DD4 7RH, UK



Installation:



Antistatic precautions must be observed when handling these modules. The PCB contains circuitry that can be damaged by static discharge.

1. The IO-RMA should only be installed by a competent, suitably trained technician, experienced in installation with hazardous voltages. (>50Vac & <1000Vac or >75Vdc & 1500Vdc)
2. Ensure that all power is disconnected before carrying out any work on the IO-RMA.
3. Maximum cable is 2.5mm², care must be taken not to over tighten terminals.
4. When mounting the IO-RMA care should be taken not to stress the PCB when fitting to the DIN rail. If it is necessary remove the module from the DIN rail, be sure to use a flat bladed screwdriver to release the DIN clips.
5. The IO-RMA is designed to operate from a 24Vac/dc supply (so that power can be drawn from a 24Vac transformer used for other purposes if a 24Vdc supply is not available). In either case one side of the supply is common to the signal ground from the BEMS controller.
6. The relay outputs are single Pole Change Over (SPCO) so they can be wired as Normally Open (N/O) or Normally Closed (N/C).
7. The 0-10Vdc signal input requires a minimum of 1mA to operate.

LED Status:

Power supply

Normal:

The green LED indicates the supply power condition. If power supply is normal (between 22V and 40V \pm 0.2V hysteresis) the green LED is ON continuously, showing that the IO-RMA is powered correctly.

Low Supply Voltage:

If power supply falls below about 21.8V the green LED double flashes twice a second;

*_*_*_*_*_*_*_*_*_*_*_*_*_*_*_*

The low power condition clears at about 22.0V. The relays behave as normal.

High Supply Voltage:

If the power supply is above 40V the green LED flashes 6 times a second;

*_*_*_*_*_*_*_*_*_*

All the relays are switched off (except when forced ON by jumper settings) as excessive voltage might overload the voltage regulator.

For pricing or any further information, please contact Omni Instruments Ltd.

Contact Details:

Tel: +44 845 9000 601
Fax: +44 845 9000 602
Local Tel: 01382 443000
Email: info@omni.uk.com

Mailing Address:

Suite E, East Kingsway Business Centre,
Mid Craigie Trading Estate, Mid Craigie Road,
Dundee, DD4 7RH, UK



LED Status (continued):

The relays are switched off:

- For 2 seconds after power-up
- When the supply is greater than 40V
- For 2 seconds after any over 40V condition clears

This prevents the relays from switching on and off during power-up or power failure with an over voltage power supply.

Control Input Voltage

The red LED indicates input voltage condition, normally the red LED is off

High Input:

If the input voltage exceeds 11V, $\pm 0.2V$ hysteresis, the red LED goes on continuously. The relays behave as if 10Vdc were applied. The input voltage should settle on one 'voltage band'. Voltage is deemed to have settled after it has been within one band for 250ms. If it has not settled for 500ms it is deemed to be unstable. If it is unstable the red LED flashes 6 times a second:

*_*_*_*_*_*_*_*

The relay outputs remain at their last settled value.

Mode Select Error:

If the mode select jumper is missing or there is an inconsistent setting (such as connecting 2 jumpers) then this is an error. The red LED does triple flashes:

*_*_*_*_*_*_*_*_*_*_*_*_*_*_*_*_*_*

The relays are switched off.

Low Input:

If the input voltage goes below 1.5Vdc, $\pm 0.2Vdc$ hysteresis, when 2Vdc to 10Vdc input mode is selected then the red LED does double flashes:

*_*_*_*_*_*_*_*_*_*_*_*_*_*_*_*_*_*

Potentiometer Setting Error

The on-pot should be set above the off-pot, if not the red LED does triple flashes:

*_*_*_*_*_*_*_*_*_*_*_*_*_*_*_*_*_*

The relay is switched off.

For pricing or any further information, please contact Omni Instruments Ltd.

Contact Details:

Tel: +44 845 9000 601
Fax: +44 845 9000 602
Local Tel: 01382 443000
Email: info@omni.uk.com

Mailing Address:

Suite E, East Kingsway Business Centre,
Mid Craigie Trading Estate, Mid Craigie Road,
Dundee, DD4 7RH, UK

Connections:

Inputs;
 24V 24Vac/dc
 0V 0V
 0V 0V
 IP 0 to 10Vdc

Outputs;
 Relay
 NC Normally open
 NO Normally closed
 C Common
 Voltage
 0V 0V
 OP 0 to 10Vdc

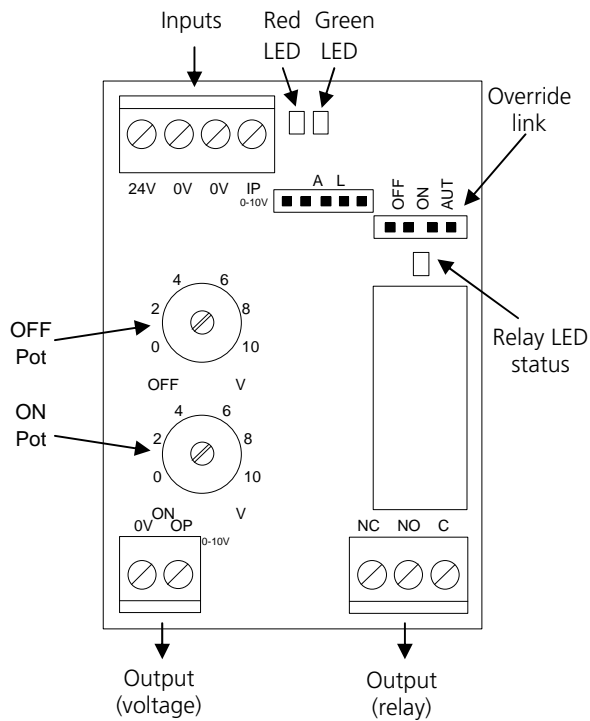

Jumper Settings:

Override:

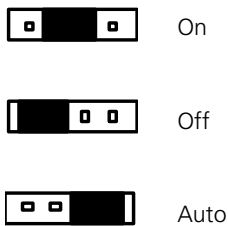

Potentiometer Locking:



For pricing or any further information, please contact Omni Instruments Ltd.

Potentiometers:

There are 2 pots, the on-pot and the off-pot. These divide the 0-10Vdc input into 3 bands. The off band, the hysteresis band and the on band. For example if the off-pot is set for 4Vdc and the on-pot is set to 6V then the off band is 0Vdc-4Vdc, the hysteresis band is 4Vdc-6Vdc and the on band is above 6Vdc

Once the input has settled, the relay is off on off band and on in the on band. In the hysteresis band the relay remains on whatever state it was in last.

If you are powering up the system with input voltage in the hysteresis band, the relay starts according to the nearest pot setting. For example, with the above settings, if the input voltage is 4.5Vdc at power-up the relay will be off, but with 5.5Vdc it will be on.

Potentiometer setting:

- With the jumper in the 'A' position you can adjust the pots to the required settings.
- A 0 to 10Vdc scale is printed on the PCB to give approximate guidance; to set the pots accurately you should adjust them to test voltages.

Locking the potentiometers:

- Once the pots have been set you can lock them. This prevents the settings from drifting or being tampered with.
- To lock the pots move the jumper to 'L'.
- To unlock the pots move the jumper back to 'A'

Note

The on-pot should be set above the off-pot.

Tech Tip:

Electrical Noise

By far the most common cause of electrical noise on a typical HVAC site is the contactor. Little, if any, electrical noise is produced when the contactor coil is energized, but significant noise is produced when the coil de-energizes, and may exceed 700Vac P-P. Typically, the contactor coil is switched by the C & N/O contacts of an IO-RM module relay.

Fitting an "RF snubber" across the contactor coil is a good way of greatly reducing the electrical noise pulse produced when the coil de-energizes. The ROXBURGH flying lead RC network type XEB1201 (Farnell part code 1187659) is a tried and trusted component for this purpose. Alternatively, a suitable MOV (metal oxide varistor) across the IO-RM C & N/O relay contacts will also help to prevent electrical noise being induced."

Whilst every effort has been made to ensure the accuracy of this specification, we cannot accept responsibility for damage, injury, loss or expense from errors or omissions. In the interest of technical improvement, this specification may be altered without notice.

For pricing or any further information, please contact Omni Instruments Ltd.

Contact Details:

Tel: +44 845 9000 601
Fax: +44 845 9000 602
Local Tel: 01382 443000
Email: info@omni.uk.com

Mailing Address:

Suite E, East Kingsway Business Centre,
Mid Craigie Trading Estate, Mid Craigie Road,
Dundee, DD4 7RH, UK