

General purpose, top-entry velocity transducer with DC output. Made from robust stainless steel throughout for continuous vibration monitoring in harsh environments. Sealed to IP67 with industry standard two-wire 4-20mA output proportional to sensor range that can connect directly to PLC, DCS and other industrial controllers. Includes integral 3-pin 62GB connector and is available with a wide range of mountings.

## MTN/1185

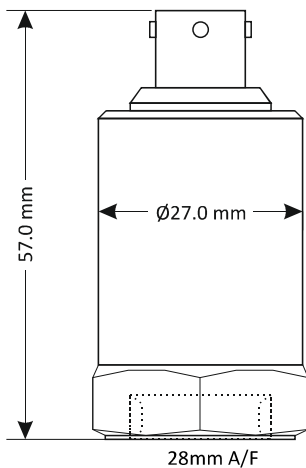

## Dimensions



Pin A — +ve  
Pin B — not connected  
Pin C — 0V

## Applications

- Air handling units
- Building services
- Fans

## Technical

Output current	4-20mA DC proportional to rms velocity (mm/s)
Supply voltage	12-32V DC (4-20mA)
Frequency response	2Hz to 1kHz $\pm 10\%$
Mounted base resonance	5kHz (nominal)
Isolation	Base isolated
Dynamic range	50g peak
Transverse sensitivity	Less than 5%
Operating temperature	-25 to 90°C
Temperature sensitivity	0.08%/°C
Case material	Stainless steel
Mating connector	MTN/MH008
Mounting torque	8Nm
Weight	140g (nominal)
Sealing	IP67

Whilst every effort has been made to ensure the accuracy of this specification, we cannot accept responsibility for damage, injury, loss or expense from errors or omissions. In the interest of technical improvement, this specification may be altered without notice.

For pricing or any further information, please contact Omni Instruments Ltd.

### Contact Details:

Tel: +44 845 9000 601  
Fax: +44 845 9000 602  
Local Tel: 01382 443000  
Email: [info@omni.uk.com](mailto:info@omni.uk.com)

### Mailing Address:

Suite E, East Kingsway Business Centre,  
Mid Craigie Trading Estate, Mid Craigie Road,  
Dundee, DD4 7RH, UK

## Studs and grub screws



Part #	From	To
MS036	¼"-28 UNF Male	M6 Male
MS039	¼"-28 UNF Male	10-32 UNF Male
MS067	¼"-28 UNF Male	M8 Male
MS068	¼"-28 UNF Male	¼"-28 UNF Male
MS124	¼"-28 UNF Male	M10 Male
MS132	¼"-28 UNF Male	M12 Male

## Quick fit adapters

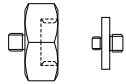

Part #	From	To
MS001	Q/F Male	Glue base
MS002	Q/F Male	M8 Male
MS003	Q/F Male	M10 Male
MS004	Q/F Male	¼"-28 UNF Male
MS006	Q/F Male	M6 Male

## Options

- Filters
- Mounting threads
- Mating cable and connector assemblies
- High temperatures
- Other velocities (see below)

Part #	Mounting	xx = Optional Velocity (mm/s rms)
MTN/1185-xx	¼" UNF Female	0-10 0-20
MTN/1185Q-xx	Q/F Female	0-25 0-50
MTN/1185NPT-xx	½" NPT Male	0-100

## Mounting adapters

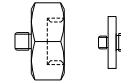

Part #	From	To
MS005	Q/F Male	¼"-28 UNF Female
MS007	Q/F Male	10-32 UNF Female
MS008	Q/F Male	M8 Female
MS011	¼"-28 UNF Male	Q/F Female
MS013	¼"-28 UNF Male	Glue base
MS033	¼"-28 UNF Male	Q/F Female
MS038	Q/F Male	M8 Conical Male
MS061	¼"-28 UNF Male	10-32 UNF Male
MS079	¼"-28 UNF Male	Q/F Female
MS106	Q/F Male	M10 Female

## Isolation

Part #	From	To
MS034	¼"-28 UNF Male	¼"-28 UNF Female
MS093	Q/F Male	M8 Male

## System connection

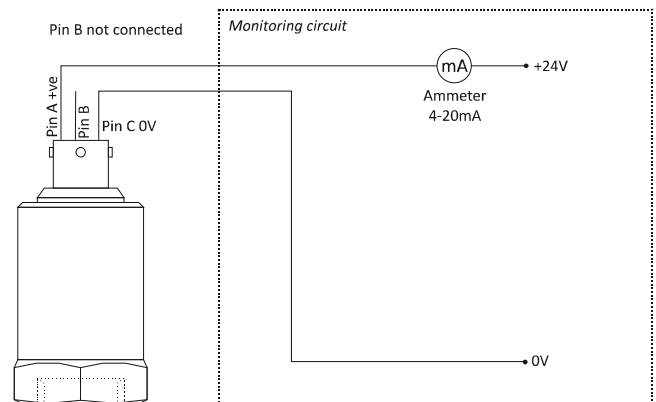

For pricing or any further information, please contact Omni Instruments Ltd.