

## GMX301 Compact Weather Station

The MaxiMet range of compact weather stations is designed and manufactured by Gill Instruments. MaxiMet products use reliable, high quality instruments to provide accurate meteorological information in a wide variety of applications.

### GMX301 Features

**Temperature, humidity, pressure.** A combined instrument mounted inside three double louvered, naturally aspirated radiation shields with no moving parts. The results are high performance across each measurement over long periods of time.

**Solar radiation.** An integrated solar radiation sensor/pyranometer. This highly accurate instrument uses a thermal sensor mounted at its base and protected by a single glass dome to record the amount of light in watts per metre<sup>2</sup>. It is widely used in agro-meteorological applications and for monitoring the performance of solar panels.



TEMP, HUMIDITY & PRESSURE	SOLAR RADIATION	PARAMETERS
<ul style="list-style-type: none"> <li>Air Pressure / Temperature</li> <li>Relative / Absolute humidity</li> <li>Naturally aspirated UV stable radiation shield</li> <li>Protection against wind-blown precipitation/dust</li> </ul>	<ul style="list-style-type: none"> <li>Complies with ISO 9060 and WMO Guidelines</li> <li>Output in watts per metre<sup>2</sup></li> <li>180° hemispherical field of view</li> <li>Records sunshine hours</li> <li>Integrated Hukseflux LP02 pyranometer</li> <li>Glass dome</li> </ul>	<ul style="list-style-type: none"> <li>Solar radiation <math>w/m^2</math></li> <li>Sunshine hours <i>hrs</i></li> <li>Temperature °C / °F / °K</li> <li>Relative humidity % Rh, <math>g/m^3</math>, <math>g/kg</math></li> <li>Barometric pressure <i>hPa, bar, mm Hg</i></li> <li>Wet bulb temperature °C / °F / °K</li> <li>Absolute humidity <math>g/m^3</math></li> <li>Air density <math>kg/m^3</math></li> <li>Outputs <i>RS232, 422, 485 (ASCII), SDI-12, NMEA, MODBUS, Analogue (option)</i></li> </ul>

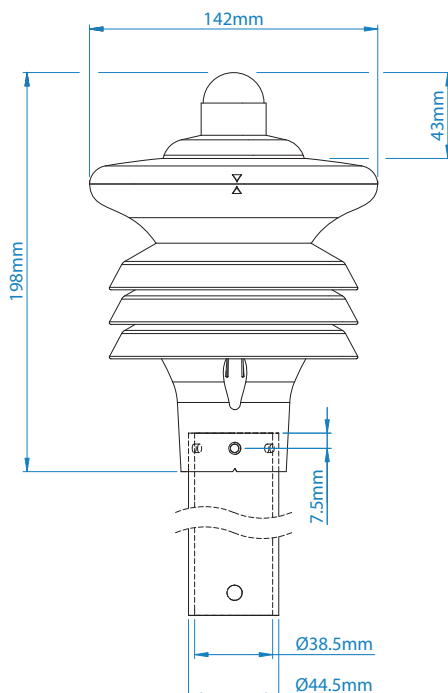

### All MaxiMet Models Feature

- Quality Measurements
- Lightweight and Robust
- Low Power Mode
- Free of Charge Software
- Gill Proven Reliability
- Compact Integrated Design
- Real Time Output
- Easy Installation
- Gill Customer Support
- 2 Year Warranty

## Applications

- Building and Industrial Controls
- Authorities
- Transport
- Coastal
- Agricultural
- Safety
- Educational
- Commercial
- Energy

TEMPERATURE	
Range	-40°C to +70°C
Resolution	0.1
Accuracy	± 0.3°C @ 20°C
Sampling Rate	1 Hz
Units	°C, °F, °K

PRESSURE	
Range	300 to 1100
Resolution	0.1 hPa
Accuracy	± 0.5 hPa @ 25°C
Sampling Rate	1 Hz
Units	hPa, bar, mmHg, inHg

POWER	
Power Supply	5 to 30 Vdc
Power (Nominal) 12 Vdc	25 mA continuous high mode. 0.7 mA eco-power mode (1 hour polled)

HUMIDITY	
Range	0-100%
Resolution	1%
Accuracy	± 2% @ 20°C (10%-90% RH)
Sampling Rate	1 Hz
Units	% Rh, g/m3, g/Kg

GLOBAL SOLAR RADIATION	
Wavelength Sensitivity	300 to 3000 nm
Output Range	0 to 1600 w/m <sup>2</sup>
Resolution	1 w/m <sup>2</sup>
DIN Standard	ISO 9060 Second Class
Sampling Rate	1 Hz
Units	w/m <sup>2</sup>

ENVIRONMENTAL CONDITIONS	
IP Rating	66
Operational Temperature Range:	-40°C to +70°C
EMC Standard:	BS EN 61326 : 2013 FCC CFR47 parts 15.109
CE Marking	YES
RoHS compliant	YES
Weight	0.6 Kg
Origin	UK

DEW POINT	
Range	-40°C to +70°C
Resolution	0.1
Accuracy	± 0.3°C @ 20°C
Units	°C, °F, °K
Sampling Rate	1 Hz

OUTPUTS	
Output rate	1/s, 1/min, 1/hr
Digital Comms Modes	Serial RS232, RS422, RS485, SDI-12, NMEA, MODBUS, ASCII
Analogue Outputs	Available via separate optional device

Specifications may be subject to change without prior notice

Whilst every effort has been made to ensure the accuracy of this specification, we cannot accept responsibility for damage, injury, loss or expense from errors or omissions. In the interest of technical improvement, this specification may be altered without notice.

For pricing or any further information, please contact Omni Instruments Ltd.