

# ORT 230/240 series Torque Transducer



For pricing or any further information, please contact Omni Instruments Ltd.

**Contact Details:**

Tel: +44 845 9000 601  
Fax: +44 845 9000 602  
Local Tel: 01382 443000  
Email: [info@omni.uk.com](mailto:info@omni.uk.com)

**Mailing Address:**

Suite E, East Kingsway Business Centre,  
Mid Craigie Trading Estate, Mid Craigie Road,  
Dundee, DD4 7RH, UK



# Digital ORT 230/240 series Torque Transducer

The ORT 230/240 Transducer offers an ideal means for precise dynamic measurement of rotary and static torque less than 100Nm and for bandwidths of up to 50Khz.

The new TorqSense ORT 230/240 torque sensors replace the E200 ORT series and feature all new electronics that have produced significant performance gains in resolution, frequency response, reduced sensor current consumption and faster digital data throughput.

## Benefits

- Low inertia – High Speed capability because electronics are not fixed onto shaft
- Non contact/brushless measurement
- High Bandwidth
- 200% safe mechanical overload
- Excellent noise immunity
- Separate digital electronics
- Operates both statically and dynamically - clockwise/anti-clockwise
- Any full scale torque can be specified within standard range: 10mNm through to 100Nm
- Lifetime warranty



## TorqSense ORT 230 series transducers offer:

- Fixed voltage or current analog outputs (one for torque and the other for speed or power) for interfacing with analog instrumentation
- BIT Self-diagnostics for letting the manufacturer know that the transducer's torque, speed ratings and calibration due date have not been exceeded.
- Simple 'Sensor status' output pin
- Sensors to monitor shaft temperature for better compensation and accuracy

## Whereas, TorqSense ORT 240 series transducers offer:

- Digital outputs, such as RS232, CANbus and USB, for interfacing with modern instrumentation and laptops
- Digital input for configuring transducer via PC
- 2 x user selectable voltage or current analog outputs (one for torque and the other for speed, power or peak torque) for interfacing with analog instrumentation
- Transducer configuration software to allow user to changes transducer variables
- BIT Self-diagnostics for letting users know data is trustworthy, that the transducer's torque, speed ratings and calibration due date have not been exceeded
- Simple 'Sensor status' output pin
- Sensors to monitor shaft temperature for better compensation and accuracy
- Ability to connect up to 10 transducers using USB

## Technology

An extensively developed measurement principle is used, in which the intensity of light beams is measured by means of photovoltaic detectors, and the electrical output is used to provide precise indication of the applied torque transmitted by the shaft.

The use of this technique results in a transducer being able to sense torque bi-directionally, have a fast mechanical and electrical response, low inertia, and complete freedom from brushes or complex electronics. The absence of brush gear allows high-speed operation with a continuous rating of up to 30,000 RPM standard. Further increases in RPM are available as an option depending upon shaft size.

The torque shaft is of low compliance  $\frac{1}{2}^\circ$  maximum torsion deflection on the smaller transducers, and  $\frac{1}{4}^\circ$  maximum on the larger transducers, at full-scale deflection. The lamps providing the light source are selected to ensure long life and high stability with the light intensity automatically controlled within the transducer body by a monitor cell.

## TORQVIEW Software

TorqView is an easy to use advanced torque monitoring software, available to assist data recording and instrumentation displays that interface with Windows based PCs.

Features include: 3 types of display, text files compatible with Matlab and Excel and Real time chart plotting.

See TorqView datasheet TSE2099R for more details.



LabView VIs are available for users to design their own process control applications. DLLs are also available for users to write their own custom software.

Data parameters measured at 20°C



## Standard

Cable length	1.5metres to interface box	Safe mechanical overload	200% of rating
Accuracy	TBC	Hysteresis	Better than 0.1%
Bandwidth	50Khz	Bearings	Deep grooved shielded bearings with oil lubrication
Temperature Range	-10°C to +50°C	Temperature coefficient	Less than 0.05% per °C

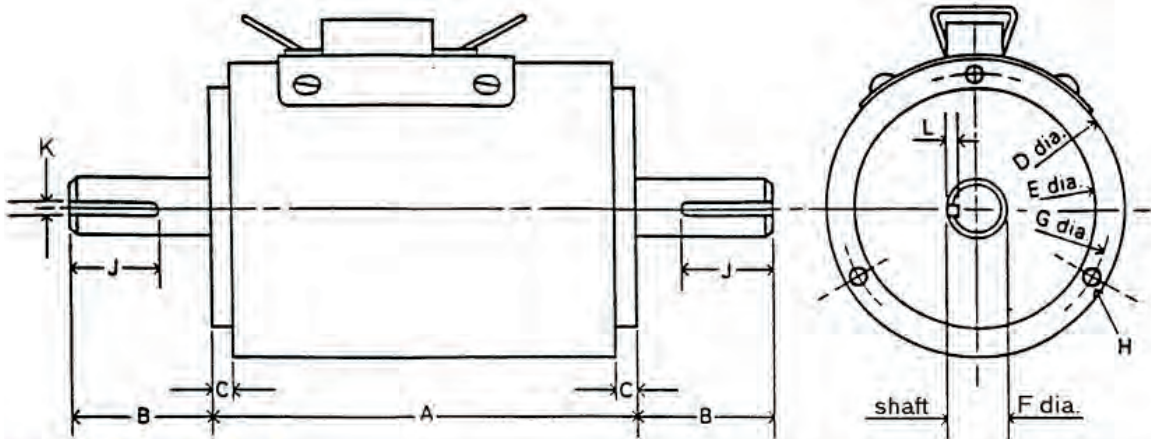

## Mechanical Parameters

Model	Dimensions (mm)											
	A	B	C	D	E	F	G	H	Depth	J	K	L
ORT230/240 -C,-D,-E	75	25.4	1.5	62	50	6.35	56	M3	5	N/A	Plain	N/A
ORT230/240 -F	75	25.4	1.5	62	50	6.35	56	M3	5	19.05	Flat	0.183
ORT230/240 -G	105	38	1.5	62	50	12.7	56	M3	6.35	30	3.96	1.98
ORT230/240 -H	130	60	1.5	62	50	20	56	M3	11	53	6	3.5

## Standard Specifications

Model	Torque Range *		Maximum Speed (RPM)	Shaft Type
	Minimum	Maximum		
ORT230/240-C	0 to 10mNm (0 to 1ozf.in)	0 to 20mNm (0 to 3ozf.in)	30000	Plain
ORT230/240-D	0 to 25mNm (0 to 3.5ozf.in)	0 to 100mNm (0 to 10ozf.in)	30000	Plain
ORT230/240-E	0 to 150mNm (0 to 15ozf.in)	0 to 750mNm (0 to 100ozf.in)	30000	Plain
ORT230/240-F	0 to 800mNm (0 to 7lbf.in)	0 to 1Nm (0 to 10lbf.in)	30000	Flat
ORT230/240-G	0 to 1.5Nm (0 to 15lbf.in)	0 to 20Nm (0 to 200lbf.in)	20000	Keyways
ORT230/240-H	0 to 25Nm (0 to 250lbf.in)	0 to 100Nm (0 to 1000lbf.in)	15000	Keyways

\* Calibration is possible in any equivalent SI, FPS or MKS units, e.g. gf.cm, lbfft, cNm  
 Transducers may be specified to any torque range between the maximum and minimum for each model.  
 For example ORT241-C 15mNm, or ORT231-G 10Nm

Data parameters measured at 20°C

# ORT 230/240 Series Electronics Module

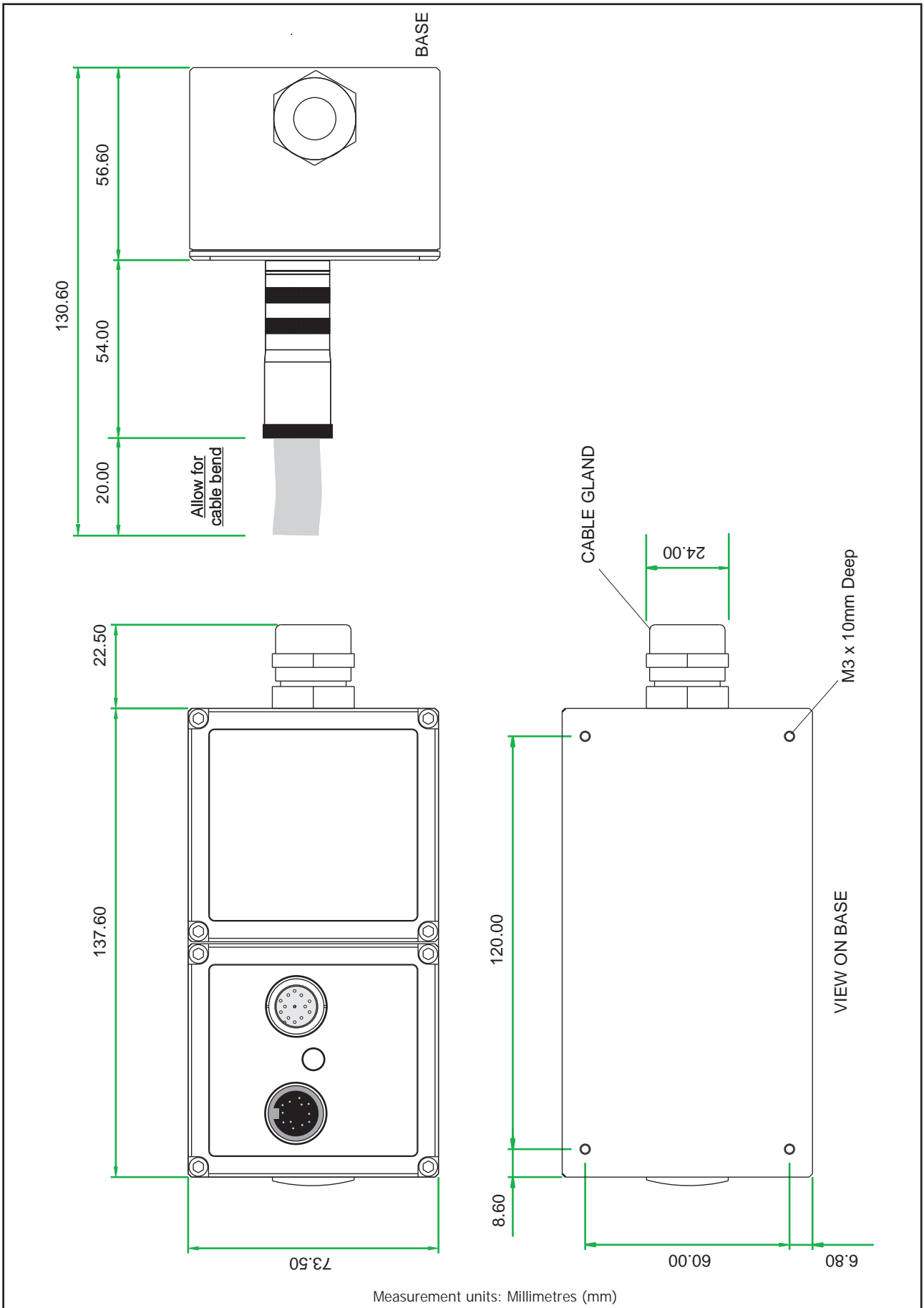

Data parameters measured at 20°C

## ORT 230/240 Series Torque Transducers - Data Specification

Parameter	Condition	Data	Units						
<b>Rotation speed/angle of rotation measurement system</b>									
Measurement method	Opto switch through slotted disc								
Direct output signal	Pulse output direct from opto switch (TTL, 5V square wave), output is independent of any analog or digital processing.								
Digital Processing Techniques Processing modes run simultaneously and can be applied to either analog channel or accessed individually via a digital connection.	<b>Processing Method</b>	<b>Update rate for analog and digital outputs</b>							
	Mode 1 (Slow Method) Frequency Count	1							
	Mode 2 (Fast Method) Period Count	0 RPM	1						
		< 2000 RPM	RPM						
> 2000 RPM	$RPM \times ( 1 / ( \lfloor (RPM - 1) / 2000 \rfloor + 1 ) )$		Hz						
Rotational speed (max)	(See Note 1)	30,000	20,000      15,000	RPM					
<b>Temperature</b>									
Measurement method	IR temperature sensor monitoring actual shaft temperature								
Temperature accuracy	±1			°C					
Reference temperature, T <sub>RT</sub>	20			°C					
Operating range, ΔT <sub>O</sub>	-10 to +50			°C					
Storage range, ΔT <sub>S</sub>	-20 to +70			°C					
Temperature drift (FS)	Max	0.05		%FS/°C					
<b>Specifications</b>									
Combined non-linearity and hysteresis	TBC			%FS					
Resolution	0.02			%FS					
Repeatability	0.1			%FS					
<b>ORT 230 Series Transducers ONLY</b>									
Accuracy	20°C, SM (See Note 2)	TBC			%FS				
3dB Bandwidth	(See Notes 3&4)	TBC			Hz				
<b>ORT 240 Series Transducers ONLY</b>									
Digital averaging	(See Note 3)	2	4	8	16	32	64	128	N
Accuracy	20°C, SM (See Note 2)	TBC	TBC	TBC	TBC	TBC	TBC	TBC	%FS
3dB Bandwidth	(See Note 4)	TBC	TBC	TBC	TBC	TBC	TBC	TBC	Hz
<b>Analog output</b>									
Output voltages (Torque/Speed/Power)	Options available: ±1 / ±5 / ±10 / Unipolar (ORT230 Series default setting is ±5Vdc) (ORT240 Series output voltages are user selectable)								Vdc
Load impedance	Maximum 1								KΩ
Output currents (Torque/Speed/Power)	Options available: 4-20 / 0-20 / 12±8 (ORT240 Series output currents are user selectable)								mA
4-20mA Loop resistance	Should not exceed 400								Ω
<b>Digital output (ORT240 Series Transducers ONLY)</b>									
Connections	CAN Bus				RS232			USB	
Configuration	CAN 2.0B, 11bit Message Identifiers				Data Bits: 8, Parity: None, Stop Bits: 1			USB 2.0 Full-Speed	
Baud Rate(s)	1 Mbps, 500 Kbps, 250 Kbps, 100 Kbps				115200 bps, 38400 bps, 9600 bps			12 Mbps	
Output Rate (Note 5)	Up to 10 KHz				Up to 1.1 KHz			Single Transfer	Up to 500 Hz
								Bulk Transfer	Up to 10 KHz
<b>Power supply</b>									
Nominal voltage, V <sub>S</sub>	12 to 32 (max)								V
Current consumption, I <sub>S</sub>	230 (max) @ 12 VDC								mA
Power consumption, W <sub>S</sub>	3								W
Allowed residual ripple of supply voltage, V <sub>ripple</sub>	500 (above nominal supply voltage)								mVp-p
<b>Electromagnetic compatibility</b>									
EMC compatibility	EN 61326:2006								

- Note 1: Please consult factory for applications requiring rotational speeds that exceed maximum figures given. Transducers fitted for IP65 will have running speeds considerably reduced, increased drag torque and accuracy can be affected.*
- Note 2: SM – Static Mode. Dynamic values will depend upon user application and has to be adjusted accordingly.*
- Note 3: Digital averaging can be configured by user to optimise accuracy/frequency response for specific user applications. Digital averaging default setting is N=16. For details see User Manual.*
- Note 4: >5Khz Sample Rate. Up to 10Khz sample rate possible, please consult factory. Digital averaging also affects the analog output, max analog output 3dB Bandwidth = 5Khz when digital average is 1.*
- Note 5: Output rate figures are calculated from the time taken to capture 10000 torque readings. Testing was conducted with each connection method configured at its maximum baud rate. The maximum output rate available for CAN and USB is dependant on the transducers setup. USB - USB is a host based bus architecture, because of this the output rate achievable will be affected by other bus traffic and host activity. USB has two transfer modes, Single Transfer which requests 1 reading at a time and Bulk Transfer which transfers readings in blocks of 50 Torque/Speed pairs. CAN Bus - to achieve a Torque reading output rate of 10KHz, the Speed reading output rate must be reduced to 100Hz.*

Data parameters measured at 20°C

## ORT 230/240 Series Torque Transducers - Standard Range

● – Standard feature    ◇ – Optional feature

	ORT 230/240 Series		Option Code	Remarks
	ORT 230	ORT 240		
<b>Torque, Speed, Power Outputs</b>				
Torque only	230	240		
Torque & Speed (60 pulses/rev)	231			User to specify RPM/FSD when ordering
Torque & Power (60 pulses/rev)	233			User to specify Power/FSD when ordering
Torque & Speed (60 pulses/rev) or Power		241		Outputs are user selectable
<b>Standard features</b>				
Voltage output $\pm 5v$ FSD (Fixed)	●		B	
Voltage outputs from $\pm 1v$ to $\pm 10v$ FSD and unipolar (Variable)		●		Output is user selectable
RS232 output		●		
Torque Averaging & Torque Peak		●		
Self Diagnostics	●	●		
Internal temperature measurement	●	●		Value available on ORT240 series only
Deep grooved shielded bearings with oil lubrication	●	●		
Ingress Protection (IP) 54	●	●		
Link Cable (1.5m)	●	●		From sensor head to electronics module
<b>Optional features</b>				
Keyed Shaft Ends	●	●	K	1Nm flats, below 1Nm plain
Plain Shaft Ends	◇	◇	P	Shaft length may be longer than keyed end shafts – consult factory for length. All sensors below 1Nm will be plain.
Splined Shaft Ends	◇	◇	T	Consult factory for details
Voltage output $\pm 1v$ FSD (Fixed)	◇		A	In place of Option B
Voltage output $\pm 10v$ FSD (Fixed)	◇		C	In place of Option B
Customer Specified Voltage Output (Fixed)	◇		U	In place of Option B. User to specify range/scale when ordering
Current output 0-20mA (Fixed)	◇		D	In place of Voltage output options
Current output 4-20mA (Fixed)	◇		E	In place of Voltage output options
Current output 12 $\pm$ 8mA (Fixed)	◇		V	In place of Voltage output options
Current output 0-20mA, 4-20mA & 12 $\pm$ 8mA (Variable)		◇	F	Current output is user selectable and in place of Voltage output. However user can reselect a Voltage output, if required. (Note 6)
USB2.0 full speed 12 Mbps Digital output		◇	G	
CANbus output		◇	H	In place of RS232
High Speed Bearings (See Note 7 below)	◇	◇	J	Consult factory for maximum speed allowance
Sealed Bearings	◇	◇	S	
Ingress Protection (IP) 65 –for sensor and electronics (See Note 8 below)	◇	◇	L	
Link Cable (>1.5m)	◇	◇	R	Consult factory for length

Note 6: 2 x analog channels available. Default settings are Channel 1 (voltage/current) – torque. Channel 2 (voltage/current) – speed or power, if ordered.

Note 7: At very high speeds, for better balance the factory recommend plain or splined shafts.

Note 8: Transducers fitted for IP65 will have running speeds considerably reduced, increased drag torque and accuracy can be affected.

Data parameters measured at 20°C

## ORT 230/240 Series Torque Transducers – Connector and Lead Options

Connectors & Leads	ORT 230/240 Series		Option Code	Remarks/Purpose
	ORT 230	ORT 240		
Analog Connector <i>12 Pin Lumberg (female)</i>	◇	◇	ACC 1	<i>For user to self wire</i>
Digital Connector <i>12 Pin Lumberg (male)</i>		◇	ACC 2	<i>For user to self wire</i>
Analog Lead (Length 2.5m) <i>12 Pin Lumberg (female) to 15 way 'D' type connector (female)</i>	◇	◇	ACC 3	<i>For connecting ORT to user's system via 15 pin 'D' connector</i>
Digital Lead (Length 2.5m) <i>12 Pin Lumberg (male) to 15 way 'D' type connector (male)</i>		◇	ACC 4	<i>For connecting ORT to user's system via 15 pin 'D' connector</i>
Digital Lead Adapter (Length 1m) <i>15 Way 'D' type (female) to RS232 and Power Connectors</i>		◇	ACC 5	<i>For connecting ORT to PC via RS232 [Also needs Digital Lead (ACC4) to connect to ORT]</i>
Digital Lead Adapter (Length 1m) <i>15 Way 'D' type (female) to RS232, USB and Power Connectors</i>		◇	ACC 6	<i>For connecting ORT to PC via USB (Option G) or RS232 [Also needs Digital Lead (ACC4) to connect to ORT]</i>
Digital Lead Adapter (Length 1m) <i>15 Way 'D' type (female) to CANbus and Power Connectors</i>		◇	ACC 8	<i>For connecting ORT to PC via CANbus (Option H) [Also needs Digital Lead (ACC4) to connect to ORT]</i>
Digital Lead Adapter (Length 1m) <i>15 Way 'D' type (female) to CANbus, USB and Power Connectors</i>		◇	ACC 9	<i>For connecting ORT to PC via USB (Option G) or CANbus (Option H) [Also needs Digital Lead (ACC4) to connect to ORT]</i>

## ORT 230/240 Series Torque Transducers – Additional related products

	Code	Remarks/Purpose
Transducer Display ETD	ETD	<i>Display readout</i>
AC Mains Adapter Power Supply	PSU 1	<i>For providing 12-32Vdc</i>
Transducer Signal Breakout Unit	SBU 2	
TorqView	TV	<i>Torque Monitoring Software</i>

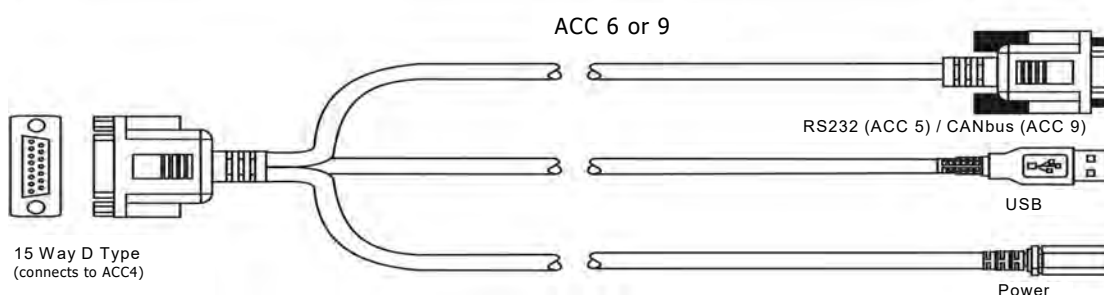
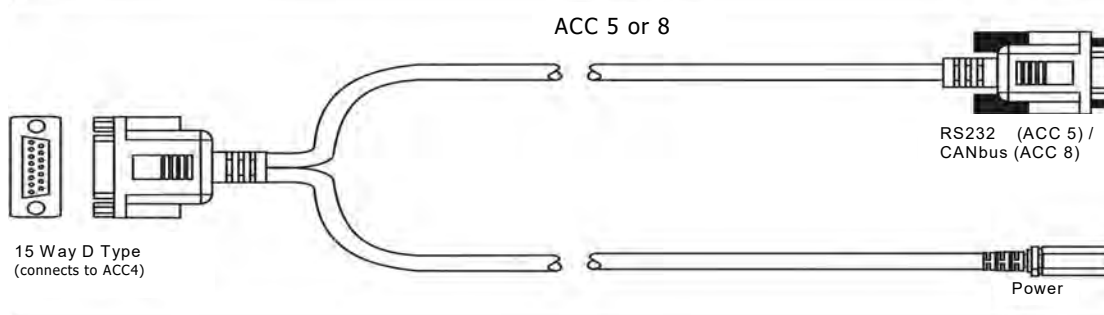
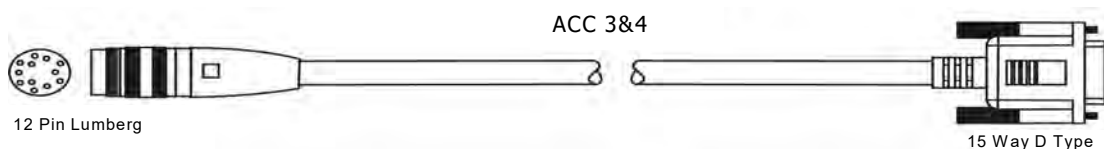

Data parameters measured at 20°C

When you order a Torque Transducer please note that any torque/FSD is possible between ranges – please specify rated torque and options using the following format:

For example: <b>ORT</b>	<b>231 - 15Nm -</b>	<b>K-CL</b>	A 'basic' transducer with torque and speed outputs, rated and calibrated to 15Nm FSD with keyed ends, ±10v and IP65 protection.
Your transducer requirement: <b>ORT</b>			
Max speed (if applicable)		RPM	
Connector & Lead options		(if applicable) <i>See over</i>	
Additional related products		(if applicable) <i>See over</i>	

### ***Glossary of terms and definitions used in this datasheet***

- ***Accuracy*** - The degree of conformity of a measured or calculated quantity, which will show the same or similar results. Accuracy of the overall TorqSense system is limited by the combined error of several factors such as linearity, hysteresis, temperature drifts and other parameters affecting measurements. If errors in the system are known or can be estimated, an overall error or uncertainty of measurement can be calculated.
- ***Digital averaging*** – The application of algorithms to reduce white noise. In any electronic system, electronic white noise is mixed with the signal and this noise usually limits the accuracy. To reduce the influence of white noise and increase the accuracy of the system different averaging algorithms can be applied. In the TorqSense system a flying digital averaging technique is applied to reduce the white noise commensurate with the level of accuracy required. However, as any averaging algorithm works as a low pass filter, the more averaging that is applied the lower the frequency response. Therefore, each Torqsense system should be optimised to the customer's requirements by choosing the right combination of accuracy/frequency response. Please see relevant part of the Datasheet and User Manual.

Data parameters measured at 20°C