

**GRAPHTEC**      GS-LXUV-UM-151

**GS-LXUV**      For **GL100**

# Illumination / Ultraviolet Sensor

## USER'S MANUAL

Thank you very much for buying this GRAPHTEC product.

This product is a measurement sensor (hereafter "module") that connects to the GL100-N/GL100-WL.

These directions describe preparations and cautions before measurement.

To ensure safety, please read the operation instructions, etc.

For details on the warnings and how to handle this module, please read the Quick Start Guide or USER'S MANUAL included on the CD-ROM (included in the GL100 packaging)

### Confirmation of the exterior

After opening the package, please confirm that there are no problems (scratches and dirt) on the exterior before use.

### Confirmation of the attached items.

- User's manual (this book): 1

If by any chance faults are found, please contact the store where you bought the item.

\* Please note that items mentioned in this book may change without prior notice.

604309092

MANUAL-UV

## 1 Part Names

This section describes the name and function of each part.

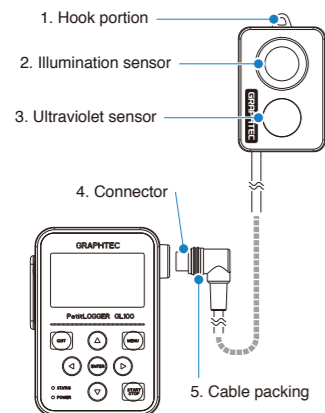

GL100 main module

- Hook portion ..... Used to mount to a wall.
- Illumination sensor ..... Sensor unit that measures illumination rays.
- Ultraviolet sensor ..... Sensor unit that measures ultraviolet rays.
- Connector ..... Used to connect to the connector on the GL100 module.
- Cable packing ..... This packing is used when connecting the connector.

**CAUTION** • When measuring ultraviolet rays that have an effect on the eyes or the skin, wear protective glasses, apply light shielding, etc.

• If the sensor unit becomes dirty, this may affect measurements. Wipe it down with a soft cloth.

• Make sure to handle the sensor unit in a way that it will not crack. If the sensor unit is cracked it may affect measurements. Replace the sensor if cracked.

After connecting the GL100 to modules or sensors, please always check/set the time and date.

## 2 How To Measure

### 1. Power supply (Refer to Quick Start Guide or USER'S MANUAL.)

Connect this module while power is being supplied to the GL100 by a battery or USB cable.

### 2. Start-up and operation

#### (1) Screen display menu flow

After power-on, the GL100 is ready for operation by holding down [MENU] key. When the module is connected, "Module Type Recognition" screen is displayed. When the module is not connected, "Module Unconnected State" screen is displayed.

Operate in accordance with the displayed instructions.



#### Module unconnected state

<Operation>  
Connect the module.



#### Recognition of module types

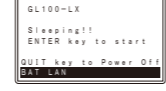

#### Standby state

<Operation>  
Press [ENTER] key.



#### Module start-up

#### (2) Free-running screen

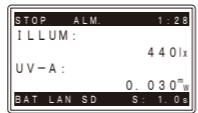

Hold down the [QUIT] key (approx. three seconds) to put the module into standby state.

When running on batteries, the module will automatically go into standby state after three minutes of no operation.

Press the [ENTER] key while in standby state to return to the free-running screen.

### 3. Setting

#### (1) Setting screen operation

##### Item selecting screen

Press the [MENU] key on the free-running screen to go to the setting screen.

<How to set>

Select the item with the directional keys (Δ▽◁▷) and press the [ENTER] key.



If the submenu shows ↓ then there are selections in those directions.

#### Numerical entry screen

<How to set>

Numbers can be inputted by increasing or decreasing the value with the Δ and ▽ keys.

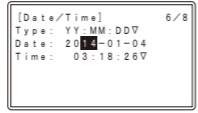

#### (2) AMP setting

The ultraviolet ray range is a fixed 30 mW/cm². Please set the measurement level to the illumination level.

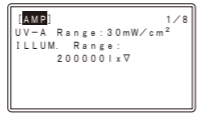

AMP input condition settings	
Range	ILLUM 2000, 20000, 200000 lx

#### (3) DATA setting

Set the Sampling and Capture Mode those will be recorded to the data recording media.

The recorded data's size will be displayed in the information for the SD card being recorded to. Please take note of it.

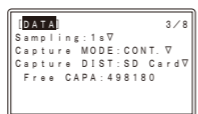

DATA recording condition setting	
Sampling	500 ms, 1, 2, 5, 10, 20, 30 s, 1, 2, 5, 10, 20, 30, 60 min
Capture MODE	CONT, 1 Hour, 24 Hour
Capture DIST	Memory, SD card

#### (4) TRIGGER setting

Select the conditions for beginning data recording after measurement starts.

- Off : Pressing the [START/STOP] key on this module will start/stop recording.
- Start : The recording will start with the trigger source conditions after pressing the [START/STOP] key. The recording will stop after pressing the [START/STOP] key.
- Stop : The recording will start after pressing the [START/STOP] key and will be stopped with the trigger source conditions.



TRIGGER capture condition settings	
TRIG setting	Off, Start, Stop
TRIG Source	Off
Alarm	Date, Time

#### (5) ALARM setting

Set the alarm information. The parameters will vary depending on the setting range. Please set the number level.



#### ALARM settings

Alarm	Off
Level / Mode	Off
ILLUM	Off
UV-A	Off

## 3 Recording

### (1) Recording

Press the [START/STOP] key to start measuring with the set conditions.

After pressing [START] key, when the module is in awaiting recording start, "ARMED" is displayed, and then when recording is started, "REC" is displayed.

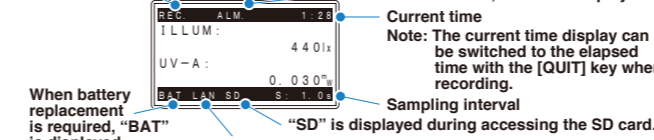

\* You can switch to the Accumulation screen with the ◀ and ▶ keys when recording data.

The module's status is shown with the lamp display.

#### STATUS (Orange)

Accessing SD card	Access light
Low battery	Flash once every 5 seconds
Alarm active	Flash once every 10 seconds

#### POWER (Green)

Power supplying	Flash once every 10 seconds
Wireless LAN connection possible status	Flash once every 5 seconds

**CAUTION** • When accessing an SD card, do not remove the SD card. The data may not write properly or the SD card may be damaged.

• When "low battery" is displayed, replace the battery or connect the USB interface to supply power as soon as possible. Caution: Batteries cannot be replaced when recording data. Replace them after the recording has finished.

### (2) Recording completion

- Press the [START/STOP] key to stop measuring.
- The screen display will change to the standby screen display.
- Press [ENTER] key to change to the free-running screen display.

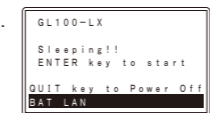

## 4 How To confirm The Data

Check the recorded data with the application software included with this module using the method below (for details, refer to the USER'S MANUAL).

- Connect the USB interface and check the online data
- Insert the SD card into PC and check the data directly
- Check the data directly from PC via wireless LAN

## 5 Specifications

Item	Contents
Measurement data	Illuminance, ultraviolet, accumulated illuminance, accumulated ultraviolet intensity * The accumulated illuminance and ultraviolet intensity are displayed only when recording.
Measurement channel	Illuminance: 1 channel UV intensity: 1 channel
Measurement range	Illuminance: 0 to 200k lx UV intensity: 0 to 30 mW / cm²
Measurement accuracy*1	Illuminance: ±5% (at 25°C) Ultraviolet intensity: ±5% (at 25°C)
Spectral sensitivity	Illuminance: 400 to 750 nm (peak 560 nm) UV intensity: 260 to 400 nm (peak 370 nm)
Measurement resolution	Illuminance: 0.1 lx UV intensity: 0.001 mW/cm²
Responsive	Illuminance: 1 ms or less UV intensity: 1 ms or less
Accumulated function	Accumulated illuminance: 0 to 999,999 k lxh Accumulated UV intensity: 0 to 999,999 mW/cm²h
Sampling interval	0.5, 1, 2, 5, 10, 20, 30 sec. 1, 2, 5, 10, 20, 30, 60 min.
Alarm	OFF / Level
Cable length	approximate 20 cm
Usage environment	-10 to 50°C, 80% RH or less (non-condensing)
External dimensions [WxDxH] (approximate)	46 x 66 x 19 mm (not including protruding parts)
Weight (approximate)	65 g

\*1 This is the measurement accuracy when our standard light source is used and compared with the calibrated test instrument.

## 6 Combined Measurement

### 1. Combined illumination / ultraviolet sensor and CO<sub>2</sub> sensor measurement

Composite measurement can be done by using the branch adapter for GS (GS-DPA) and the CO<sub>2</sub> sensor (GS-CO2) (each sold separately).

**WARNING** If the CO<sub>2</sub> sensor (GS-CO2) is included in the assembly, it cannot be powered with batteries.

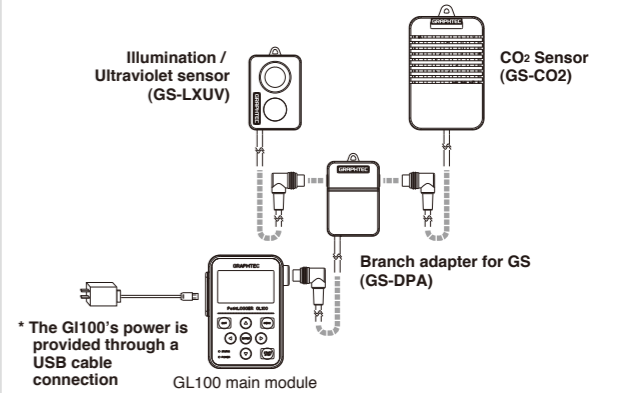

\* The GL100's power is provided through a USB cable connection

GL100 main module

(1) Screen display menu flow  
After connecting the power supply, connect this module and operate it in accordance with the content displayed on the screen.

\* Refer to "2 How To Measure" above and the USER'S MANUAL for the CO<sub>2</sub> sensor.

### (2) Free-running screen

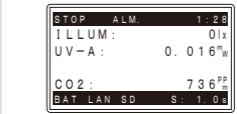

Hold down the [QUIT] key (approx. three seconds) to put the module into standby state. Press the [ENTER] key while in standby state to return to the free-running screen.

### 2. Combined illumination / ultraviolet sensor and temperature and humidity sensor measurement

Composite measurement can be done by using the branch adapter for GS (GS-DPA) and the temperature and humidity sensor (GS-TH) (each sold separately).

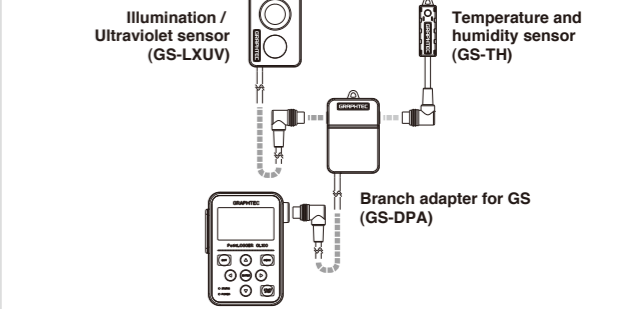

GL100 main module

### (1) Screen display menu flow

After connecting the power supply, connect this module and operate it in accordance with the content displayed on the screen.

\* Refer to "2 How To Measure" above and the USER'S MANUAL for the temperature and humidity sensor.

### (2) Free-running screen



Hold down the [QUIT] key (approx. three seconds) to put the module into standby state. When running on batteries, the module will automatically go into standby state after three minutes of no operation. Press the [ENTER] key while in standby state to return to the free-running screen.

#### < Extension cable >

The module can be used approx. 1.5 m away from the GL100 by using an extension cable for GS (GS-EXC). However, you cannot connect and use multiple extension cables.

#### CAUTION

It is not possible to be used by connecting two same sensors.

#### <Spectral Sensitivity Characteristic>

