

## 190P ULTRASONIC FLOW METER MANUAL



For pricing, or any further, information please contact Omni Instruments Ltd  
Tel: +44 (0)845 9000 601 or visit our website at [www.omniinstruments.co.uk](http://www.omniinstruments.co.uk)

# CONTENTS

<b>1.0</b>	<b>Introduction</b>	
	Principle of operation.....	1.1
	Standard instrument kit list.....	1.2
	Instrument connections.....	1.3
	Key pad.....	1.4
	Battery charging.....	1.5
	Selection of the measuring point.....	1.6
	Application of ultrasonic couplant.....	1.7
	How to set the separation distance and mount the sensors...	1.8
<b>2.0</b>	<b>Basic operating system description</b>	
	Start reading flow at a new pipe in easy steps.....	2.1
	Data logger.....	2.2
	Site configuration.....	2.3
	Sensor modes or operation.....	2.4
	RS232 Configuration.....	2.5
	Calibrating the current output.....	2.6
	Setting the date and time.....	2.7
	Sensor parameters and Factory settings.....	2.8
	Application options.....	2.9
	Correction settings.....	2.10
	Configure the Current output.....	2.11
	Configure the Pulse output.....	2.12
	Flow Menu.....	2.13
	Pipe dimension units.....	2.14
<b>3.0</b>	<b>Other Information</b>	
	Operating conditions.....	3.1
	Error messages.....	3.2
	Specification.....	3.3
	Tables.....	3.4

## 1.0 Introduction

The Precision Flow 190P is a portable hand held clamp-on non invasive flow meter that measures liquid flow in closed pipes or conduits.

### 1.1 Principle of operation

Ultrasonic waves are transmitted in the direction of flow. These are accelerated slightly by the velocity of the liquid in the channel. When ultra-sound is transmitted in the opposite direction, the flow of the liquid causes the transmitted sound to decelerate. The subsequent time difference is directly proportional to the flow velocity in the channel. Having measured the flow velocity and knowing the cross-sectional area, the volumetric flow is calculated. Time differences are resolved to a resolution of 20 pico seconds.

### 1.2 Standard instrument Kit

A standard 190P includes the following Items:

- 190P hand held, battery and mains powered flow meter with built in battery, data logger, totaliser, 4-20mA output, pulse output and RS232 port.
- Two standard temperature X type transducers for pipe sizes 15mm – 1200mm. General service temperature  $-30^{\circ}\text{C}$  to  $+105^{\circ}\text{C}$  short term up to  $130^{\circ}\text{C}$  with 2.95 metre cables.
- Support guide rail for use up to  $220^{\circ}\text{C}$  and pipe sizes up to 400mm
- Two diagonal support brackets for use up to  $105^{\circ}\text{C}$  and with pipe sizes from 50mm to 1200mm.
- Two diagonal support bracket extension straps.
- Switching AC/DC power adapter 100Vac to 240Vac input to 12 V output.
- Mains lead.
- RS232 to PC cable
- Tube of ultrasonic coupling compound
- Hard carry case.
- Manual.

Your instrument kit may contain additional or alternative components according to your particular order. Please check you have all of these items.

### 1.3 Instrument connections

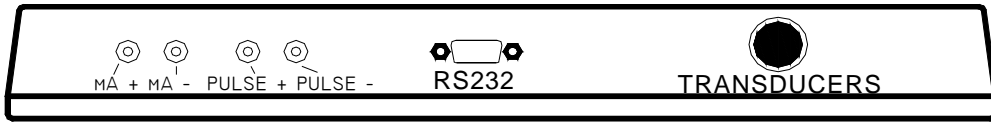

Figure 1



Figure 2

### 1.4 Instrument key pad

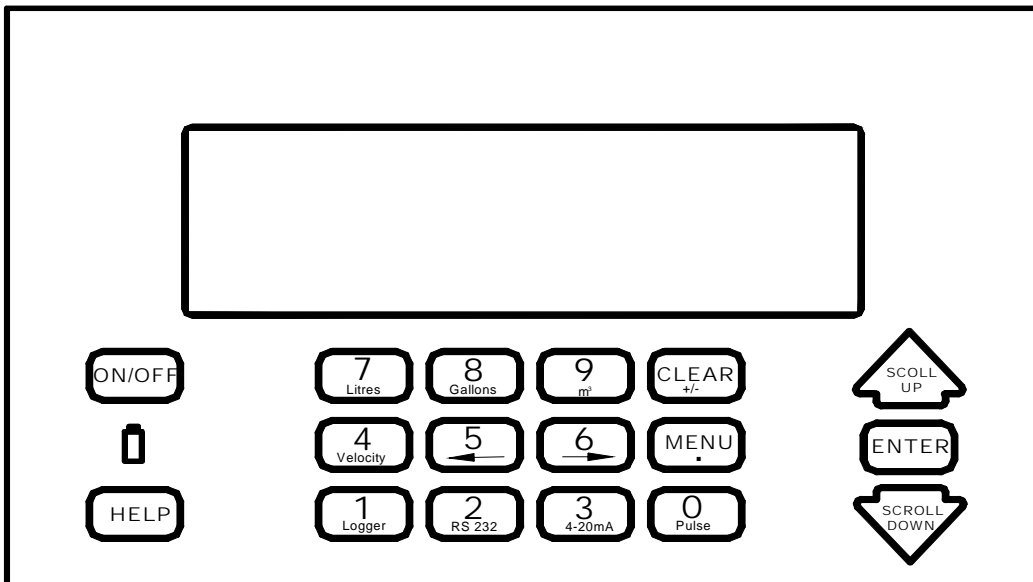

Figure 3

### 1.5 Battery Charging

Plug the mains charger into the wall. Connect the output to the 12V DC input connector on the 190P (see figure 2). Trickle charge is indicated when the green LED (battery symbol on the front panel is continuously on, figure 3). Fast charge is indicated when the Green LED flashes. Battery charge level is indicated by the on screen battery symbol. Turn the unit on to see this. It takes 4 hours to give a 90% charge, 5 hours to fully charge the battery. The charger supplied requires an earthed mains connection. The first charge the unit receives from new should be for 10 hours. Leaving the continuously connected will not harm the battery. The unit is intended for use while not connected to the charger.

## 1.6 Selection of a measuring point

To perform a reliable and accurate measurement the point of measurement must be selected carefully. To ensure this, the application must have a pipe and fluid that is sonically conductive and a fully developed flow profile (most standard pipe materials and fluids with a viscosity less than  $1000\text{mm}^2/\text{s}$ ). Ensure the point on the pipe where the sensors are positioned is always filled completely with no bubbles or deposit material accumulate in the pipe at the measuring point.

Flow profile position guidelines:

Elbows, valves, pumps, T-sections, reducers, diffusers, and other pipefittings all cause flow profile distortion. As with all single beam ultrasonic flow meters it is important to have an axi-symmetrical shape flow profile.

The 190P will still give accurate results even under non-ideal measuring conditions. Follow the guidelines below to ensure best performance.

**Horizontal pipe:** avoid mounting the transducers on the top or the bottom of the pipe as solid particles are deposited on the bottom of the pipe and gas pockets can develop at the top. About 45 degrees from the vertical is usually a good place see figure:

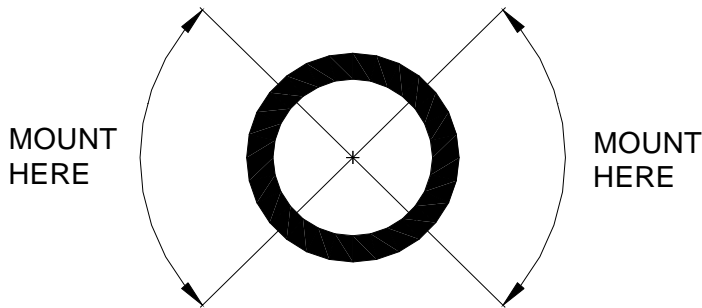

Figure 4

**Vertical Pipe:** Choose a site where the liquid flow is up this will help ensure the pipe is always completely filled.

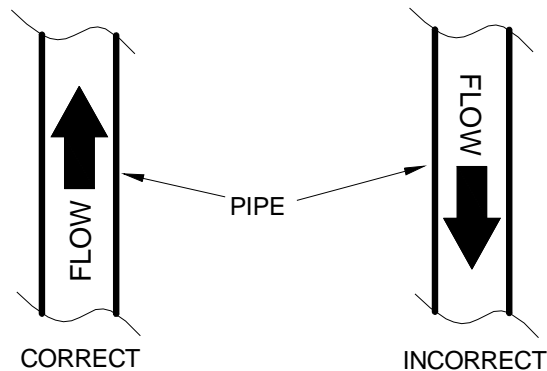

Figure 5

In the following table recommendations for straight inlet pipe lengths are given for common types of **up stream flow disturbance**, normally 20 diameters will give acceptable results.

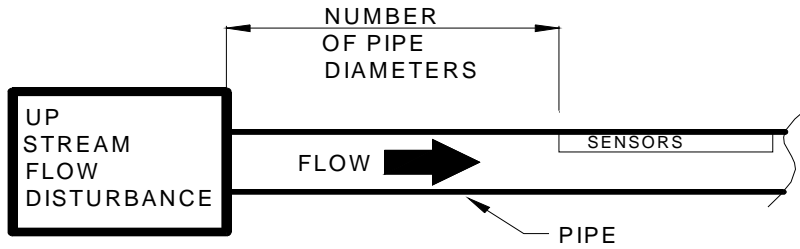

Figure 6

**Disturbance source up  
Stream to measurement**

**Pipe diameters to sensor position**

Valve non full bore or butterfly type	40
Fully open Ball valve	10
90° elbow	15
2 90° elbows in one plane	30
2 90° elbows in different planes	40
T connector	50
Expander	30
Reducer	15
Pump	50

In the following table recommendations for straight outlet pipe lengths are given for common types of **down stream flow disturbance**, normally 10 diameters will give acceptable results.

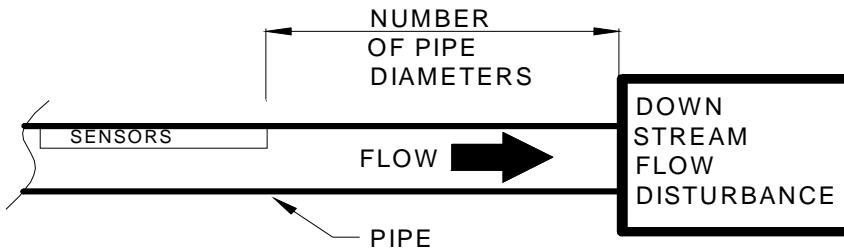

Figure 7

**Disturbance source down  
Stream to measurement**

**Pipe diameters to sensor position**

Valve non full bore or butterfly type	10
Fully open Ball valve	10
90° elbow	10
2 90° elbows in one plane	10
2 90° elbows in different planes	10
T connector	10
Expander	10
Reducer	10
Pump	50

## 1.7 Application of ultrasonic couplant

Ensure pipe walls are clean and free from loose paint and rust before attaching the sensors.

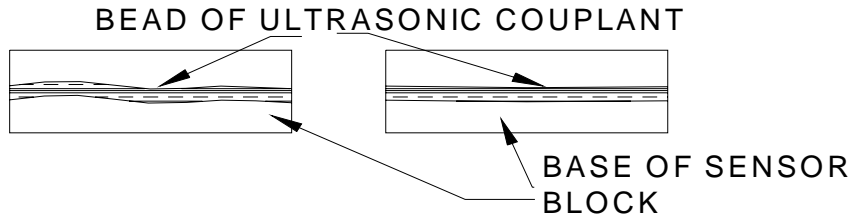

Figure 8

## 1.8 How to set the separation distance and mounting instructions

### 1.8.1 Reflex mode

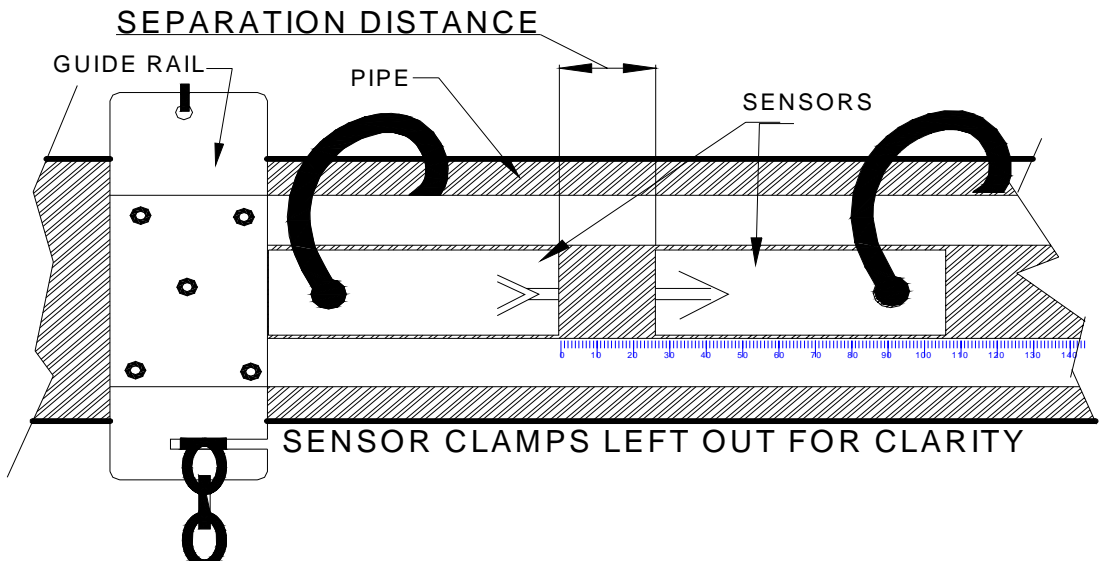

Figure 9

### 1.8.2 Diagonal Mode

Relationship of sensors:

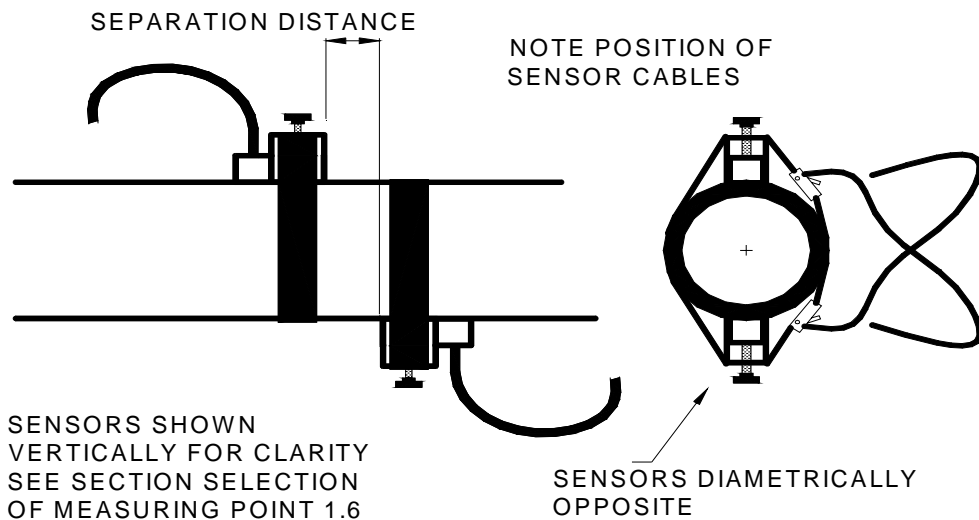

Figure 10

### 1.8.3 Marking pipe for sensor position

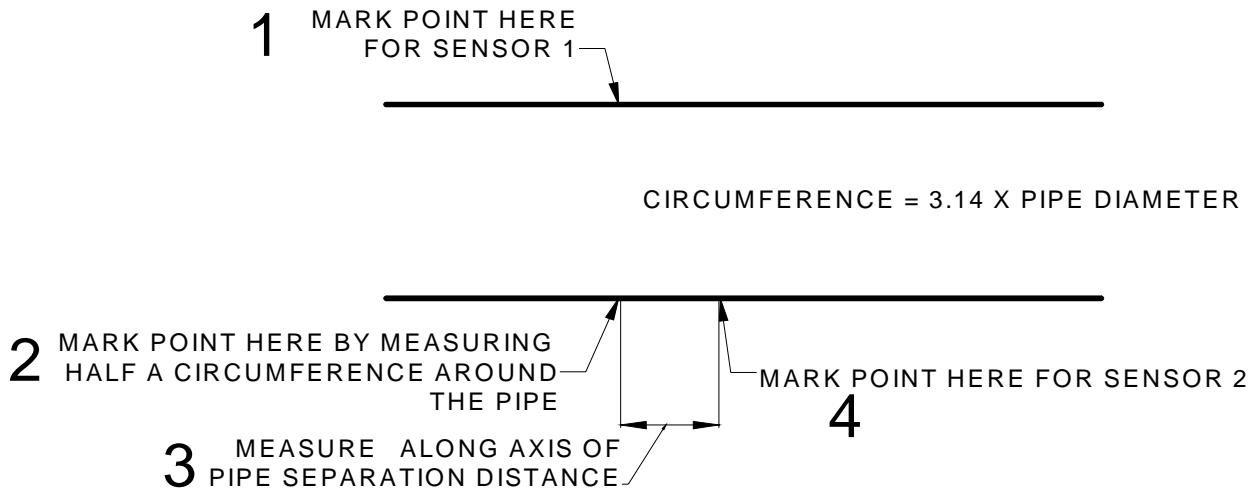

Figure 11

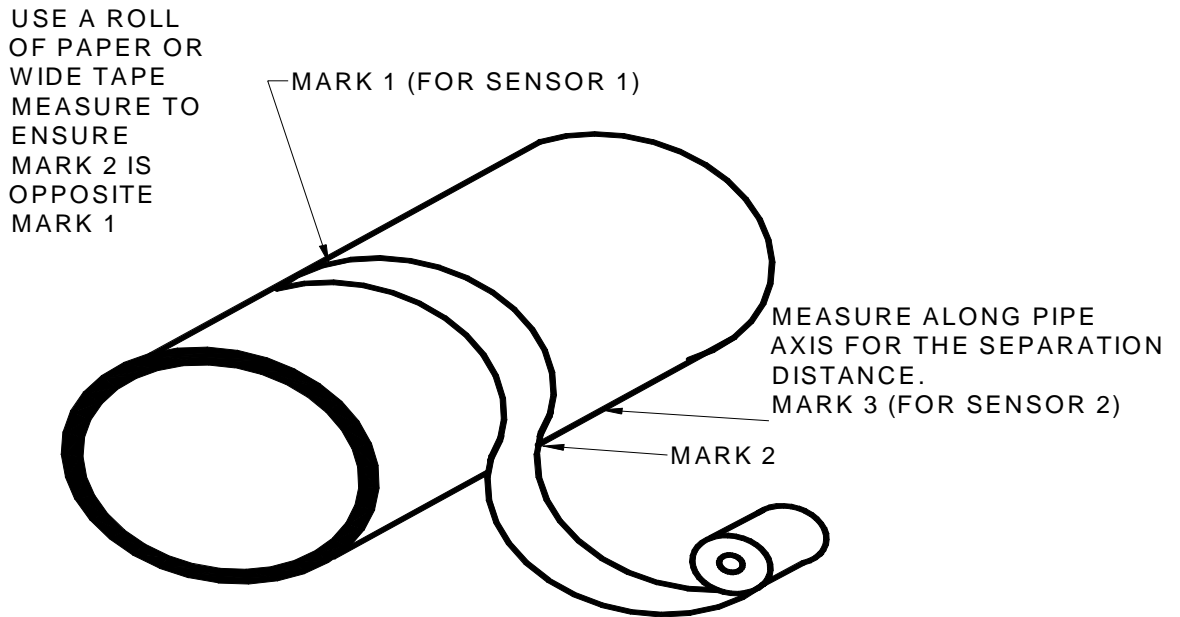

Figure 12



## 2.0 Basic operating system description.

The generic menu based operating system is easily navigated using the scroll keys to highlight a sub-menu title or variable. Press **ENTER** to display that menu or edit a variable. Pressing the **HELP** key at any time while navigating a menu gives information on that feature. Note: you must enter a menu for help on that menu, not just highlight it. All 190P configuration is easily performed by following the on screen instructions.

### 2.1 Start reading flow at a new pipe in easy steps.

Make sure the battery is charged and that you are familiar with section 1. Press ON/OFF to start again.

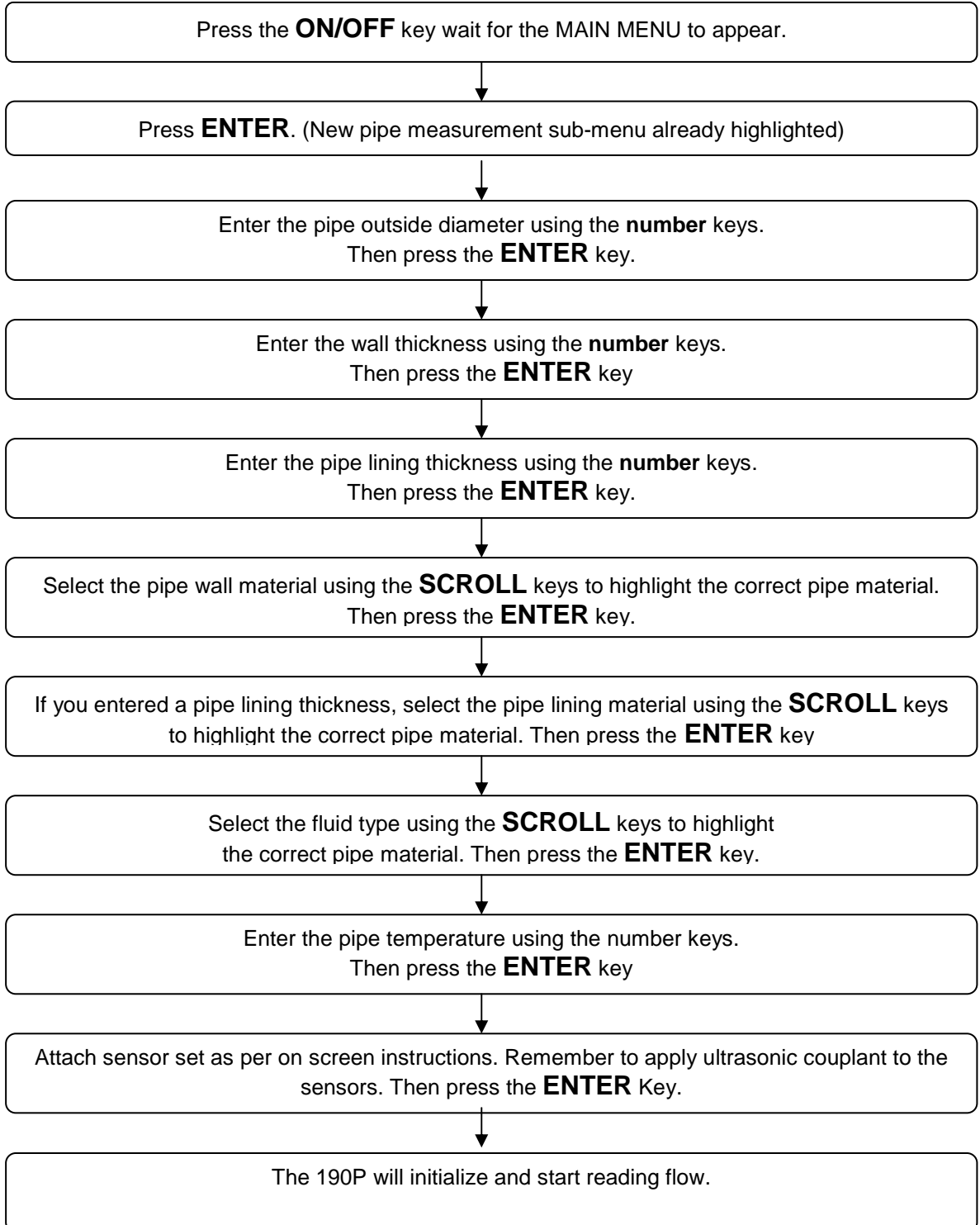

## 2.2 Data Logger

### 2.2.1 Overview

The built in data logger has the capacity to store 60,000 flow readings. Data can be stored in 5-second to 1-hour intervals. Data from each Logging session can be saved with a unique name and is stored in the memory until it has been cleared. The stored data can be displayed on the instrument in text or graphical format. The instrument is also capable of downloading the stored data via the RS232/USB output port to a printer or PC onto a standard spreadsheet.

The data logger has 2 control menus one in the main menu and one accessible during the flow screen by pressing the logger button.

The logger menu accessible during the Flow Screen is used to: name the log, set start and stop times, set the log interval, view the logged data and clear the logged data.

The logger menu accessible from the Main Menu is used to: up load logger data and view logged data as text or in a graphical format change the logger units and clear the logged data.

To change the display units highlight the Units menu entry and press the relevant units button for example the 9 key will make the units  $m^3$ .

To edit the start and stop dates and time, highlight the date and time using the scroll keys then press the **ENTER** key to initialise editing the date and time. The value is adjusted by pressing the scroll keys. Pressing the **ENTER** key sets the value on the adjusted variable and moves the cursor to the next value to be adjusted until all are set.

To view logged data as text select the View log as text Menu item.

To view logged data as in graphical format first check and set if necessary the menu item Graph Y axis max value to a sensible value for your flow rates then select the View log as graph menu item.

Using the scroll keys to navigate the graph or logged text.

### 2.2.2 Down load instructions

To output the logger via RS232 / USB to another device make sure the device or program you are down loading the data to has the same RS232 configuration as the 190P.

To adjust the RS232 settings in the 190P see the section 2.5 RS232 configuration.

If you wish to connect to a PC using a USB port you must purchase the USB cable and adapter software. These are available from Precision Flow Ltd and most computer hard wear stores.

Install the cable adapter by following the instructions supplied with the adapter.

Go to **MAIN MENU**→ **Data logger**→**Download log**

The logger is stored as 250 blocks of 240 points each. Set the first block to down load then set the last block to download. Set your equipment to capture or print a text file

Then highlight and select the Download range to RS232 menu entry.

### 2.2.3 How to capture logged data in windows 98SE, ME, 2000, or XP.

Start **Hyper Terminal**, this is supplied as part of your operating system usually under: **Start → Programs → Accessories → Communications → HyperTerminal.**

If this is not available see your system administrator or download and install the program from:

[www.hilgraeve.com](http://www.hilgraeve.com)

Alternatively use another Terminal emulation program.

Give your connection a name



Then select connect direct to Com1 or whichever COM Port you are connecting to



Then set your RS232 settings to be the same as in RS232 configuration in the 190P

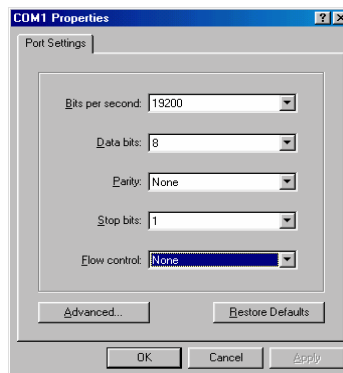

Hyper terminal now shows the following window

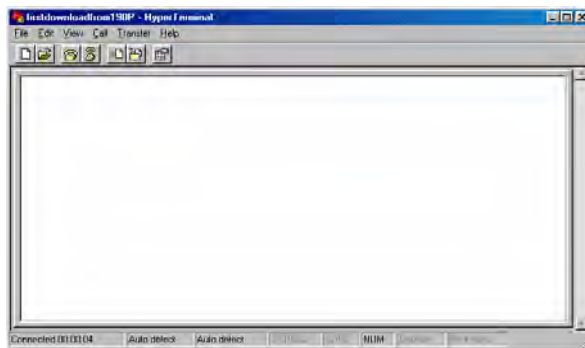

To ensure the received data is placed on a separate line set the menu entry New Line to CR + LF (Go to **Main Menu**→**Instrument config.**→**RS232 Configuration** →**New Line**) in the 190P.

Or

Append a line feed to incoming line ends Hyper terminal setting under **File**→ **properties**→**settings**→**ASCII setup.** (Terminal program)

Then

Select **Transfer** →**Capture Text**  
Enter a name for the received text file

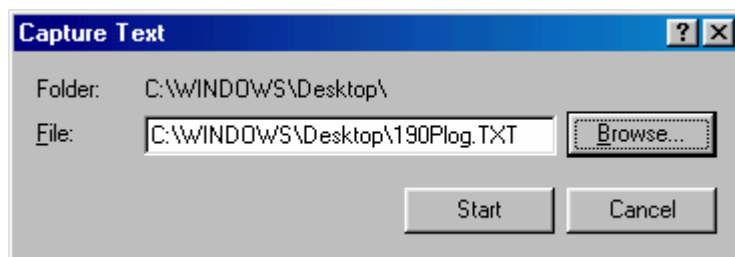

Select Start (Capture Text window)

Go to **MAIN MENU**→ **Data logger**→**Download log (190P)**

Then highlight and select the Download range to RS232 menu entry.

When the 190P has finished downloading the logged data  
Stop the transfer by selecting:

**Transfer**→ **Capture Text**→ **Stop** (Hyper Terminal window)

The logged data is now a text file, 190Plog.TXT in the example this can easily be imported in to Excel or many other spread sheet programs.

To open in Excel: Start Excel select **File**→ **Open** set **Files of types** to **All Files (\*.\*)**

Navigate to your downloaded file and select open and follow the on screen instructions.

## 2.3 Site configuration

Go to **Main menu → Site configuration**

20 site parameter sets can be stored. Site 0 is the site LAST, which is the last programmed data set. To use a site, set a site number, edit the site name and variables if required then select Read flow at the bottom of the menu.

## 2.4 Sensor mode

Go to **Main menu → Instrument config. → Sensor mode**

These should not need to be altered from the default settings. But can be useful for unusual applications.

Alternate sensor sets and modes of operation can be selected.

### SENSOR MODES

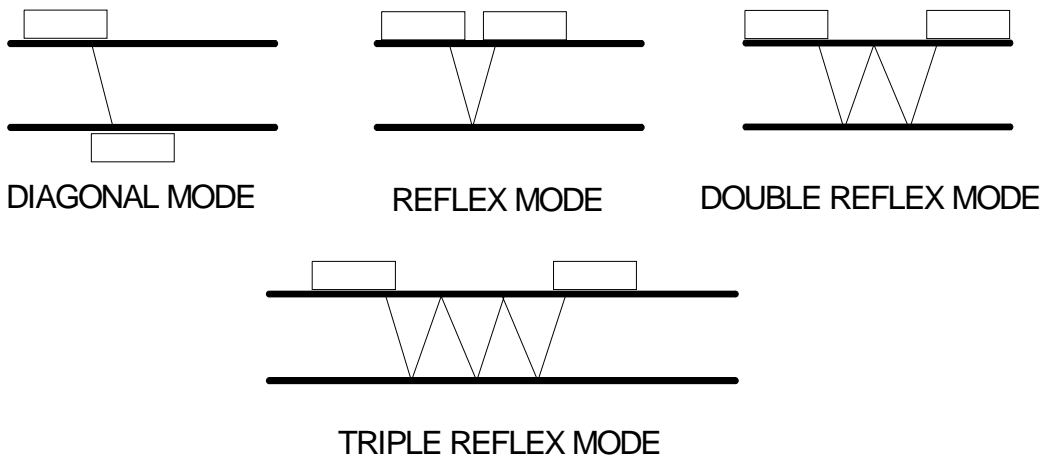

THE LINES SHOW THE ULTRASOUND PATH

Figure 13

## 2.5 RS232 configuration

Go to **Main menu → Instrument config. → RS232 configuration** or from the flow screen press the **RS232** button

Navigated the menu using the scroll keys, highlight a variable, press **ENTER** to display the variable options **SCROLL** to highlight the desired setting and **ENTER** to select it.

Selecting test will output a text string indicating the settings selected via the RS232 port.

## 2.6 Calibrating the current output.

Go to **Main menu → Instrument config. → Calibrate 4-20mA**

Press the **ENTER** key to initialise calibration.

Connect a reference current meter between the current output terminals and follow the on screen instructions.

All instruments are factory calibrated and adjustment is usually unnecessary.

## 2.7 Setting the date and time.

Go to **Main menu → Instrument config. → set date and time**

Press the **ENTER** key to initialise editing the date and time.

The value is adjusted by pressing the scroll keys. Pressing the **ENTER** key sets the value on the adjusted variable and moves the cursor to the next value to be adjusted until all are set.

## 2.8 Sensor parameters

Go to **Main menu → Instrument config.→ Sensor parameters**

These are only to be adjusted under guidance from the factory.

## 2.9 Application Options (Advanced users only)

Go to **Main menu → Instrument config.→ Application options**

Applications options allow the alteration of the profile correction settings. Reynolds Correction can be turned on or off. Fluid sound V correction can be enabled or disabled this should be enabled other than under guidance from the factory. When this feature is enabled there is no dependence on speed of sound of the fluid on the measurement other than to initially position the sensors to find a signal if the fluid sound speed changes drastically the signal may be lost and necessitate repositioning the sensors.

## 2.10 Correction settings (Advanced users only)

Go to **Main menu → Instrument config.→ Application options→Correction settings→**

**2.10.1 Roughness um**→ is the pipe wall roughness in um it is only applied in conjunction with Reynolds correction. It is used to compensate for the profile distortion caused by unevenly lined or corroded pipes. Typical values are listed in help under the Correction settings help Screen (press the **HELP** button while in the Correction Settings Menu.)

**The following 4 variables should only be adjusted under guidance from the factory.**

**2.10.2 Back wall adj** → when the received signal is reflected of the back wall of the pipe. Normally **DISABLED**

**2.10.3 AZWT**→ Adaptive **Z**oom **W**indowing **T**echnology This automatic function ensures the correct signal is used for measurement by the correlation detection system, resulting in a quick and accurate flow measurement. Normally **ENABLED**

**2.10.4 Window**→ Manual setting for signal setting only available for use when AZWT is **DISABLED**

**2.10.5 Spipe**→ this function enable the small pipe (<35mm) correction algorithm Normally **ENABLED**

## 2.11 Setting the Current output

From the flow screen press the **4-20mA** button. Configure the output to your requirements. Navigated the menu using the scroll keys, highlight a variable, press **ENTER** to display the variable options SCROLL to highlight the desired setting and ENTER to select it.

## 2.12 Pulse output

From the Flow screen press the **Pulse** button. Configure the output to your requirements. Navigated the menu using the scroll keys, highlight a variable, press **ENTER** to display the variable options SCROLL to highlight the desired setting and ENTER to select it.

## 2.13 Flow Menu

From the Flow screen press the **MENU** button. In this menu you can adjust flow settings such as Zero cut off, Set zero flow, Reset Totals, Damping and Site calibration factor. Selecting the Diagnostics menu line will display machine timing and signal quality information.

## 2.14 Pipe Dimension Units

Go to **Main menu → Instrument config. → Pipe Dimension Units**

Choose the units you enter your pipe dimensions with this will become the instruments default entry units. Return here to change them at any time.

### 3.0 Other information

#### 3.1 Operating conditions

The Precision Flow 190P can be used where the application parameter values are within the temperature and pipe sizes given in the specification. In addition to this the pipe wall and liquid to be measured must be sonically conductive. This means the pipe walls must be made of a relatively homogenous material and fluid must be free from or contain a minimal quantity of particulates or bubbles. Typically < than 3% the meter may still function above this limit, depending on the distribution of the particulates. For applications above 3 % an alternative technology machine should be used.

There is no dependency on the electrical characteristics of the fluid.  
Certain operating conditions may prevent a measurement being made these are:

##### **Heavily corroded or pipes with deposits on the wall**

The ultrasound may be too attenuated for the ultrasound to penetrate the wall. The sensitivity of the Precision Flow 190P is the best available and has been shown to work on applications where other leading manufactures machines fail to work.

##### **Lined pipes**

Lined pipes usually work well but can cause measurement difficulties if the lining is not bonded correctly to the pipe wall or consists of a material which is not sonically conductive.

##### **Porous pipe materials e.g. concrete**

Measurements are only possible for certain compositions of these materials and are some times impossible.

##### **Unexpected gas pockets**

Bubble free liquids can form gas pockets where there is a pressure change for example on a feed pipe to a pump or where the cross sectional area of the pipe expands by a large amount.

##### **Incorrect pipe data**

It should be noted that a 1 % error in internal bore would give a 2 % error in volumetric flow rate. As in all single path ultrasonic meters the 190P measures the flow velocity and calculates the volumetric flow rate using the pipe dimensions given by the user. Pipe table are notoriously inaccurate. Always try to measure pipe dimensions. Until you have measured you don't know!

### 3.2 Error messages

These can be caused by adverse operating condition (see the section on operating conditions) or more commonly by incorrect data entry. Please check pipe dimensions, material, fluid type, temperature and that you have sensors with couplant correctly applied and attached to the pipe at the correct separation distance, before calling our help line.

### 3.3 Specification

#### Hand Held Electronics

Protection Class: IP54

Material: ABS

Approval, CE, EN 61326; A1 A2 A3' EN 6100-6-3 2001, EN 61000-6-1 2001

Weight: < 1.5 Kg

Dimensions: 275 x 150 x 55mm

Display: 240 x 64 graphics LCD with backlight

Keypad: 17 key tactile membrane

Temperature range: 0°C to +50°C (operating) -0°C to +50°C (storage)

Power supply/charger Input: 1.2VDC

Volumetric flow units: m<sup>3</sup>, gallons (Imperial and US), Litres

Velocity units: metres/sec, feet/sec

Flow velocity range: 0.0 m/sec to 25 m/sec to 4 significant figures  
(Option higher if required)

Total volume: 12 digits forward and reverse

Continuous battery level indication

Continuous signal quality indication

ERROR messages

Analogue 4-20mA into 750 Ohms: User definable scaling

Resolution: 0.1 % of full scale

Pulse 5 Volts User definable scaling

Serial RS232, USB

Data logging memory capacity 60,000 data points

Data Logging output Via RS232 or displayed graphically/numerically

**Transducer Standard X type(LT) Pipe size: 15mm-300mm**

General service temp short term: -30 to 130 °C

General service temp long term: -30 to 105 °C

**Transducer Standard X type Pipe size: 15mm-1200mm**

General service temp short term: -30 to 130 °C

General service temp long term: -30 to 105 °C

**Transducer Standard X type HT Pipe size: 15mm-1200mm**

General service temp short term: -40 to 220 °C

General service temp long term: -30 to 170 °C

**Transducer Standard Y type Pipe size: 1200mm-6500mm**

General service temp short term: -30 to 130 °C

General service temp long term: -30 to 105 °C

Special application transducer design service is available please contact Precision Flow for details.

Repeatability  $\pm 0.5\%$  with unchanged transducer positions

Accuracy  $\pm 1\%$  to  $\pm 2\%$  or  $\pm 0.02$  m/sec whichever is the greater, depending on application.

The specification assumes turbulent flow profile with Reynolds numbers above 4000

Precision Flow Ltd reserve the right to alter any specification without notification

### 3.4 Tables

When fluid sound V correction is enabled, there is no dependence on speed of sound of the fluid on the measurement other than to initially position the sensors to find a signal. If the fluid sound speed changes drastically the signal may be lost and necessitate repositioning the sensors.

#### Speed of Sound in common materials

Material	Ctrans(m/s)		
304	3075	UPVC	2300
316	3175	Rubber	1900
347	3100		
Bitumen	2500		
Carbon Steel	3230		
Copper	2260		
Ductile cast iron	2650		
Lead	700		
Nylon 6	2620		



**Speed of Sound in common Liquids**

Liquid	Velocity of sound m/s
Acetate, Butyl	1170
Acetate, Ethyl	1180
Acetate, Methyl	1150
Acetate, Propyl	1180
Acetone	1170
Acetonitrile	1290
Acetonyl Acetone	1400
Acetylendichloride	1020
Alcohol, Butyl	1240
Alcohol, Ethyl	1180
Alcohol, Furfuryl	1450
Alcohol, Methyl	1120
Alcohol, Propyl (n)	1220
Alcohol, t-Amyl	1200
Alkazene 13	1320
Analine	1690
Benzene	1300
Benzol	1330
Benzol, Ethyl	1340
Bromoform	920
Butylene Glycol (2,3)	1480
Butyrate, Ethyl	1170
Carbitol	1460
Carbon Bisulfide	1160
Carbon Disulfide	1150
Carbon Tetrachloride	930
Castor Oil	1480
Chlorobenzene	1300
Chloroform	987
Cyclohexanol	1450
Cyclohexanone	1420
Diacetyl	1240
Dichloroisobutane (1,3)	1220
Diesel Oil	1250
Diethyl Ketone	1310
Diethylene Glycol	1580
Dimethyl Phthalate	1460
Dioxane	1380
Diphenyl /oxide	1500
d-Penhone	1320
Ethanol Amide	1720
Ethyl Acetate	1190
Ethyl Ether	986
Ethylene Glycol	1660
Formamide	1620
Furfural	1450
Gasoline	1250
Glycerine	1920

Glycol	1658
Gravity Fuel Oil AA	1490
Isopentane	992
Kerosene	1320
Linalool	1400
Linseed Oil	1770
Mercury 20°C	1420
Mesityloxiide	1310
Methyl Acetate	1210
Methyl Napthalene	1510
Methylene Iodide	980
Methylethylketone	1210
Monochlorobenzene	1270
Morpholine	1440
Motor Oil SAE 20	1740
M-xylol	1320
n-Hexanol	1300
Nitrobenzene	1460
Nitromethane	1330
Olive oil	1430
Parrafin	1300
Parrafin Oil	1420
Peanut Oil	1460
Pentane	1010
Petroleum	1290
Polypropylene oxide	1370
Pyridine	1410
Silicone	990
Silicone oil	1350
Sperm Oil	1440
Tert Butyl Chloride	980
Tetraethylene Glycol	1580
Transformer Oil	1390
Trichlorethylene	1050
Triethylene Glycol	1610
Turpentine	1280
Water	1480
Water Sea	1530
Water Salt Solution 10%	1470
Water Salt Solution 15%	1530
Water Salt Solution 20%	1600
Water D2O	1400
Xylene Hexaflouride	880

## Limited Warranty and Disclaimer

Precision Flow Ltd. warrants to the end purchaser, for a period of one year from the date of shipment from our factory, that all new transmitters and transducers manufactured by it are free from defects in materials and workmanship. This warranty does not cover products that have been damaged due to normal use, misapplication, abuse, lack of maintenance, or improper installation. Precision Flow's obligation under this warranty is limited to the repair or replacement of a defective product, if the product is inspected by Precision Flow Ltd and found to be defective. Repair or replacement is at the discretion of Precision Flow Ltd. If the product is outside of the warranty period a purchase order must be received from the end purchaser before repair work will start. The product must be thoroughly cleaned and any process chemicals / contamination removed before it will be accepted for return. The purchaser must determine the applicability of the product for its desired use and assumes all risks in connection therewith. Precision Flow Ltd assumes no responsibility or liability for any omissions or errors in connection with the use of its products. Precision Flow Ltd will under no circumstances be liable for any incidental, consequential, contingent or special damages or loss to any person or property arising out of the failure of any product, component or accessory. All expressed or implied warranties, including the implied warranty of merchantability and the implied warranty of fitness for a particular purpose or application are expressly disclaimed and shall not apply to any products sold or services rendered by Precision Flow Ltd. The above warranty supersedes and is in lieu of all other warranties, either expressed or implied and all other obligations or liabilities. No agent or representative has any authority to alter the terms of this warranty in any way.

For further information contact Omni Instruments by phone on +44 845 9000 601 or via email at [info@omniinstruments.co.uk](mailto:info@omniinstruments.co.uk)



**Australia / Asia Pacific Office**  
Tel +61 (0)282 442 363  
Fax +61 (0)294 751 278  
[info@omniinstruments.com.au](mailto:info@omniinstruments.com.au)  
[www.omniinstruments.com.au](http://www.omniinstruments.com.au)

**UK / Europe Office**  
Tel: +44 (0)845 9000 601  
Fax: +44 (0)845 9000 602  
[info@omniinstruments.co.uk](mailto:info@omniinstruments.co.uk)  
[www.omniinstruments.co.uk](http://www.omniinstruments.co.uk)

**USA / Canada Office**  
Tel +1-866-849-3441  
Fax +1-866-628-8055  
[info@omniinstruments.net](mailto:info@omniinstruments.net)  
[www.omniinstruments.net](http://www.omniinstruments.net)