

# ***MAG 910 / MAG 910E***

## ***MAGNETIC – INDUCTIVE FLOWMETER***

**Operating Instructions**  
**January 2006**



|          |  |           |
|----------|--|-----------|
| <b>1</b> | <b><i>Basic information</i></b>  | <b>5</b>  |
| 1.1      | <i>Basic features</i>  | 5         |
| 1.2      | <i>Standards and approvals</i>   | 5         |
| 1.3      | <i>Warranty</i>  | 6         |
| <b>2</b> | <b><i>Preparing for start up</i></b>                                     | <b>7</b>  |
| 2.1      | <i>Inspecting the contents of the package</i>                            | 7         |
| 2.2      | <i>Fuse replacement</i>  | 7         |
| 2.3      | <i>Power supply</i>  | 8         |
| 2.4      | <i>Power supply voltage selection (Mag910E, 115/230V version only)</i>   | 8         |
| <b>3</b> | <b><i>Installation</i></b>   | <b>9</b>  |
| 3.1      | <i>Sensor location</i>   | 9         |
| 3.2      | <i>Electrical connection</i>   | 12        |
| 3.2.1    | <i>Power supply</i>  | 12        |
| 3.2.2    | <i>Electric connection between converter and sensor – Remote version</i> | 13        |
| 3.3      | <i>Sensor grounding</i>  | 13        |
| <b>4</b> | <b><i>Electronic unit description</i></b>                                | <b>14</b> |
| 4.1      | <i>Front panel (display)</i>   | 14        |
| 4.2      | <i>Rear panel (inputs/outputs)</i>                                       | 15        |
| 4.3      | <i>Signal terminals</i>  | 16        |
| 4.3.1    | <i>Current loop output</i>   | 16        |
| 4.3.2    | <i>Frequency output</i>  | 17        |
| 4.3.3    | <i>Impulse output</i>  | 17        |
| 4.3.4    | <i>Status output (Mag910 only)</i>                                       | 18        |
| 4.3.5    | <i>PLC digital input (Mag910 only)</i>                                   | 18        |
| 4.3.6    | <i>Serial port RS485 (Mag910 only)</i>                                   | 19        |
| 4.4      | <i>Serial port RS232</i>   | 20        |
| <b>5</b> | <b><i>Operation</i></b>  | <b>21</b> |
| 5.1      | <i>Main menu</i>   | 21        |
| 5.1.1    | <i>Current Flowrate / Total Volume</i>                                   | 21        |
| 5.1.2    | <i>Positive Volume</i>   | 21        |
| 5.1.3    | <i>Negative Volume</i>   | 21        |
| 5.1.4    | <i>Auxiliary Volume</i>  | 21        |
| 5.1.5    | <i>Maximum Flowrate / Maximum Flowrate Time (Mag910 only)</i>            | 21        |
| 5.1.6    | <i>Maximum Flowrate (Mag910E only)</i>                                   | 21        |
| 5.1.7    | <i>Minimum Flowrate / Minimum Flowrate Time (Mag910 only)</i>            | 22        |
| 5.1.8    | <i>Minimum Flowrate (Mag910E only)</i>                                   | 22        |
| 5.1.9    | <i>Datalogger (Mag910 only)</i>  | 22        |
| 5.2      | <i>Setup menu</i>  | 22        |
| 5.2.1    | <i>Input and outputs configuration (1 INPUT/OUTPUT)</i>                  | 22        |
| 5.2.1.1  | <i>Current loop output (1.1 CURRENT)</i>                                 | 23        |
| 5.2.1.2  | <i>Frequency output (1.2 OUTPUT F)</i>                                   | 23        |
| 5.2.1.3  | <i>Impulse output (1.3 OUTPUT P)</i>                                     | 24        |
| 5.2.1.4  | <i>Pulse width (1.4 PULSE WIDTH)</i>                                     | 25        |
| 5.2.1.5  | <i>Status output (1.5 OUTPUT S) (Mag910 only)</i>                        | 25        |
| 5.2.1.6  | <i>PLC digital input (1.6 INPUT) (Mag910 only)</i>                       | 26        |
| 5.2.1.7  | <i>Low flowrate limit (1.7 LIMIT PF1)</i>                                | 27        |
| 5.2.1.8  | <i>High flowrate limit (1.8 LIMIT PF2)</i>                               | 27        |
| 5.2.1.9  | <i>Hysteresis of flowrate limits (1.9 HYSTERESIS)</i>                    | 27        |
| 5.2.1.10 | <i>RS485 baud rate (1.A RS485 B.R.) (Mag910 only)</i>                    | 27        |
| 5.2.1.11 | <i>RS485 address (1.B RS485 ADDR.) (Mag910 only)</i>                     | 28        |
| 5.2.2    | <i>Flowmeter configuration (2 FLOWMETER)</i>                             | 28        |

|                   |   |           |
|-------------------|---|-----------|
| 5.2.2.1           | Flowrate units (2.1 FLOW UNIT)                    | 28        |
| 5.2.2.2           | Flowrate resolution (2.2 FLOW RESOL.)             | 28        |
| 5.2.2.3           | Volume units (2.3 VOLUME UNIT)                    | 29        |
| 5.2.2.4           | Volume resolution (2.4 VOL. RESOL.)               | 29        |
| 5.2.2.5           | Flowrate direction (2.5 FLOW DIREC.)              | 29        |
| 5.2.2.6           | Low-flow cutoff (2.6 L.F.CUTOFF)                  | 30        |
| 5.2.2.7           | Moving average time constant (2.7 TIMECONST)      | 30        |
| 5.2.2.8           | Time setting (2.8 TIME SET.) (Mag910 only)        | 30        |
| 5.2.2.9           | Date setting (2.9 DATE SET.) (Mag910 only)        | 30        |
| 5.2.2.10          | Datalogger setting (2.A DATALOGGER) (Mag910 only) | 30        |
| <b>5.2.3</b>      | <b>General settings (3 GENERAL)</b>               | <b>31</b> |
| 5.2.3.1           | Diameter (3.1 DIAMETER)                           | 31        |
| 5.2.3.2           | Nominal flowrate range $Q_N$ (3.2 RANGE)          | 31        |
| 5.2.3.3           | Serial number (3.3 SERIAL NR.)                    | 31        |
| 5.2.3.4           | Power supply (3.4 POWER SUP.)                     | 31        |
| 5.2.3.5           | Self-test (3.5 SELFTEST)                          | 31        |
| 5.2.3.6           | Current Loop Test (3.6 C.LOOP TEST)               | 31        |
| 5.2.3.7           | Basic Menu Password (3.7 PASSWORD MN.)            | 32        |
| <b>5.2.4</b>      | <b>Calibration menu (4 CALIBRATION)</b>           | <b>32</b> |
| 5.2.4.1           | Number of Calibration Points (4.1 NR.OF CALP.)    | 32        |
| 5.2.4.2           | Calibration point 1 (4.2 CAL.POINT 1)             | 32        |
| 5.2.4.3           | Calibration point 2 (4.3 CAL.POINT 2)             | 33        |
| 5.2.4.4           | Calibration point 3 (4.4 CAL.POINT 3)             | 33        |
| 5.2.4.5           | Calibration point 4 (4.5 CAL.POINT 4)             | 33        |
| 5.2.4.6           | Calibration Password (4.6 PASSWORD CA.)           | 33        |
| <b>5.2.5</b>      | <b>Service configuration (5 SERVICE)</b>          | <b>33</b> |
| <b>6</b>          | <b>Error messages</b>                             | <b>34</b> |
| <b>7</b>          | <b>Maintenance</b>                                | <b>35</b> |
| 7.1               | Advice for correct operation                      | 35        |
| 7.2               | Periodical maintenance                            | 35        |
| 7.3               | What to do in case of failure                     | 35        |
| <b>8</b>          | <b>Application information</b>                    | <b>36</b> |
| 8.1               | Weight and dimensions                             | 36        |
| 8.1.1             | Electronic unit – compact version                 | 36        |
| 8.1.2             | Electronic unit – remote version                  | 36        |
| 8.1.3             | Sensor  | 37        |
| 8.2               | Used materials                                    | 38        |
| 8.3               | Flowrate versus diameter                          | 39        |
| <b>9</b>          | <b>Type plate</b>                                 | <b>40</b> |
| <b>10</b>         | <b>Technical data</b>                             | <b>42</b> |
| <b>11</b>         | <b>Ordering information - options</b>             | <b>43</b> |
| 11.1              | Example of order                                  | 43        |
| <b>12</b>         | <b>Electronic unit exchange</b>                   | <b>44</b> |
| <b>13</b>         | <b>Terminology</b>                                | <b>44</b> |
| <b>Appendix A</b> | <b>Measuring principle</b>                        | <b>45</b> |
| <b>Appendix B</b> | <b>MAG910 Menu structure (Mag910 only)</b>        | <b>46</b> |

## 1 Basic information

### 1.1 Basic features

**The inductive flow meter Mag910** is designed to measure, indicate and record the instantaneous and total flow of the conductive media flowing through the sensor. The flow meter Mag910 records both forward and reverse flows. As there are no moving parts in the flow profile the Mag910 can be used to measure extremely dirty liquids containing solids. The only limitation is that the flowmeter can be used solely with conductive liquids.

**Range of applications.** The inductive flow meter Mag910 is for use in the Chemical Industry, Paper Industry, Water and Wastewater Treatment Industry and most other process industries.

**Features.** The inductive flowmeter Mag910 is a highly accurate and stable device. The construction of the Mag910 flowmeter uses components with long-term, time and temperature stability. Configuration data is backed up and can be recovered after a power failure. The back-up structure enables data recovery even if a partial loss of data occurs as a result of (e.g. high level electrostatic discharge or a noisy power supply). Internal CPU provides all functions usually built in electronic flow meters, incl. low flow rate correction, frequency response setting, bandwidth of sensitivity setting at low flow rates, etc.

**Outputs.** Flowmeter Mag910 is equipped with 6 standard isolated outputs: 4 to 20mA either active or passive, frequency output, impulse output, status (relays) output, RS485 and RS232 output. User can configure these outputs. Status and RS485 outputs are not available for Mag910E.

**Power supply.** Both versions of the standard 115V/230V power supply and 24V DC/AC power supply are available.

### 1.2 Standards and approvals

Electromagnetic flowmeter is conformed to requirements for bearing CE mark.



- Electromagnetic flowmeter electronic unit, both remote and compact version meet safety requirements according to standard EN 61010-1 including amendment A2.
- Electromagnetic flowmeter electronic unit, both remote and compact version meets EMC requirements according to standard EN 61000-3, EN 61000-4, EN 61000-6
- Pipe with sensor meets requirements of Pressure Equipment Directive 97/23/EC.
- Both the pipe and electronic unit, meet the requirements of degree of protection provided by enclosure level IP67, according to EN 60529 (IEC 529).

### ***1.3 Warranty***

Within the manufacturers general supply conditions, all material and manufacturing faults are covered by that. It is up to us whether the warranty obligation includes a repair free of charge or corresponding replacement. Place of the warranty obligation is Czech Republic. Further claims on compensation, especially for loss of production or resultant of damages, are strictly excluded.

Any defects caused by improper use are absolutely not included in the warranty. Excluded from warranty are also expendable items (as i.e. accumulators, batteries, pushbuttons after attained life time, ribbons, etc.)

In case of a warranty claim the user is asked to give detailed description of the defect and also of the application for which you use the product. This information is important in order to avoid time and cost extensive tests and for the eventual achievement of warranty claims from our suppliers and sub-suppliers. For the item or instrument, returned after the expired warranty time, repair or replacement on warranty can only be accepted, if manufacturer has been informed in time that a warranty case has occurred.

Warranty period for all types of electromagnetic flowmeter is 24 months.

***The flowmeter should only be used according to the instructions described in this operating manual.***

## 2 Preparing for start up

### 2.1 Inspecting the contents of the package

Basic package includes the following items:

- Flanged sensor
- Electronic Transmitter (can be integral or remote)
- Spare fuse
- Operating manual.
- Calibration certificate
- Special wrench for opening the housing covers
- Magnet for control without opening the housing
- Software Flow910
- RS232 cable

The flowmeter is delivered ready for use after connecting to the power supply. Please check that it has been correctly installed according to chapter “Installation”.

Only a power supply with the appropriate voltage and frequency should be used. The flowmeter can be supplied with either 230/115V 50/60Hz, or 24V (12V, 48V) DC/AC power supply, see ordering information in chapter “Power supply”.

### 2.2 Fuse replacement

A mains fuse is located behind the back cover. The fuse must only be exchanged by a competent person. Procedure is as follows:

- Disconnect the power supply from the flowmeter.
- Unscrew the back cover using the special wrench (standard part of delivery).
- The fuse holder is located behind the back cover. Remove the fuse. Replace it with new fuse with the same rating.
- Screw on the back cover.
- Reconnect the power supply.

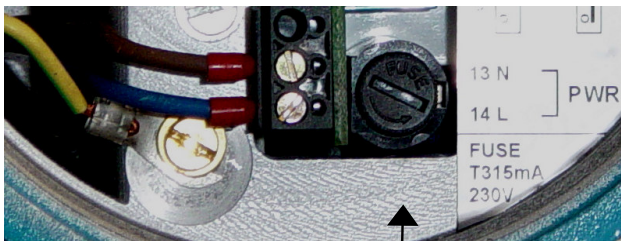

Fuse holder

*Note:*

- *T315mA fuse is used for 115/230 V version*

- 1A fuse is used for 24 and 48 V DC/AC versions
- 2A fuse is used for 12 V DC/AC version

### **2.3 Power supply**

From a power supply point of view the flowmeter is delivered in four basic versions:

- **115/230V** (+10%, -15%), 50/60Hz, automatic switching for Mag910 (manual switching for Mag910E)
- **12V DC** (+20%, -10%), 12V 50/60Hz (+10%, -10%)
- **24V DC** (+20%, -10%), 24V 50/60Hz (+10%, -10%)
- **48V DC** (+20%, -10%), 48V 50/60Hz (+10%, -10%)

### **2.4 Power supply voltage selection (Mag910E, 115/230V version only)**

Mag910E is equipped with a power supply voltage selector, which enables the use of both 115VAC and 230VAC supply voltage. The selector is located on the PC board (see below). It is accessible after removing the cover as follows:

- Disconnect the power supply from the flowmeter.
- Unscrew the back cover using the special wrench (standard part of delivery).
- The power supply voltage selector is located behind the back cover. Move the jumper to the required position.
- Screw on the back cover.
- Reconnect the power supply.

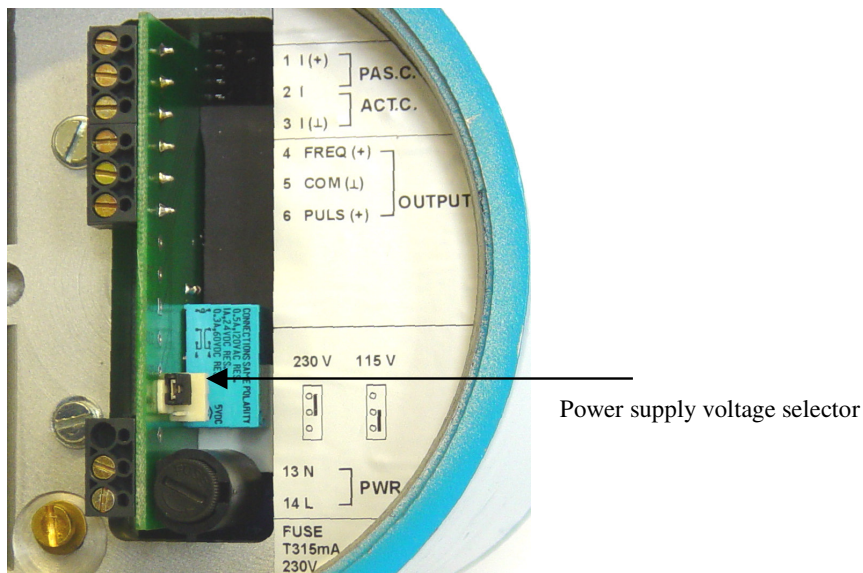

Note: Mag910 is equipped with automatic power supply selector.

### 3 Installation

#### 3.1 Sensor location

To avoid measuring errors due to gas/air entrainment or to a partly filled pipe, please observe the following:

##### Horizontal (standard) mounting

The sensor tube must always remain full. The best way to achieve this is to locate the sensor in a low section of pipe, see the following picture. It is recommended to install the sensor in a section of straight pipe with at least 5 times the pipe diameter before sensor and 3 times after sensor.

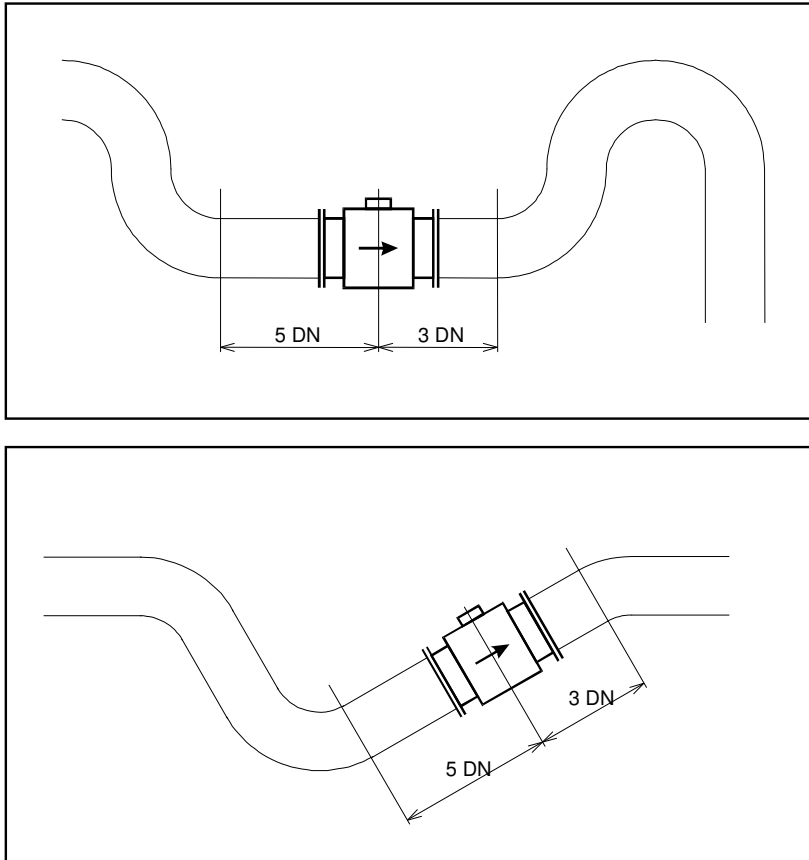

##### Pipe reducers

If the pipe diameter is not the same as the diameter of sensor, then pipe reducers can be used. So as not to lose accuracy of the measurement, the slope of reducers should not exceed 8°.



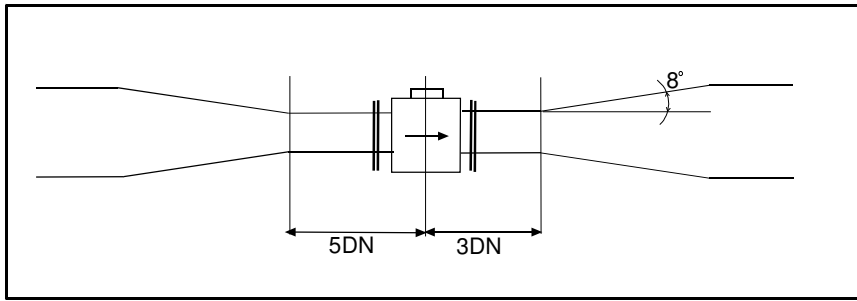

### Vertical mounting

When the sensor is mounted on a vertical section of pipe, the flow direction must be upwards. In the case of a downward flow direction, air bubbles can collect in the sensor and the measurement could be unstable and inaccurate.

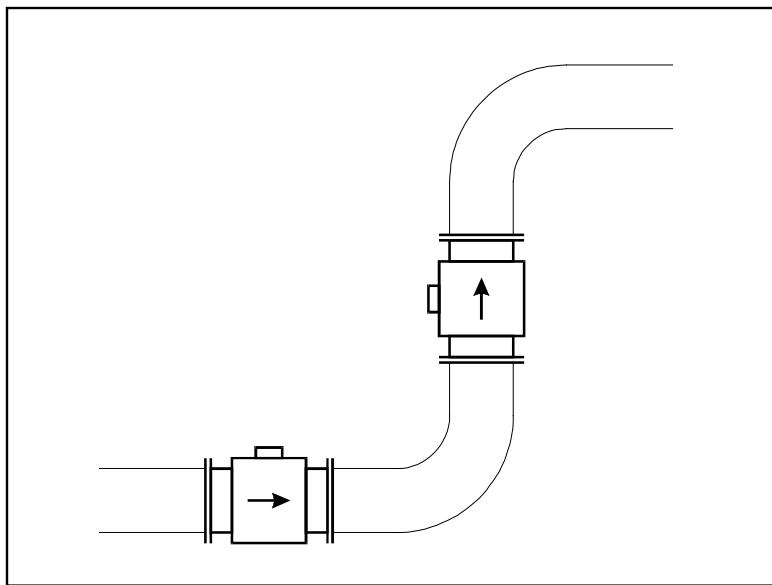

### Pumps

Never install the sensor on the suction side of a pump or on a section of pipe where a vacuum is possible.

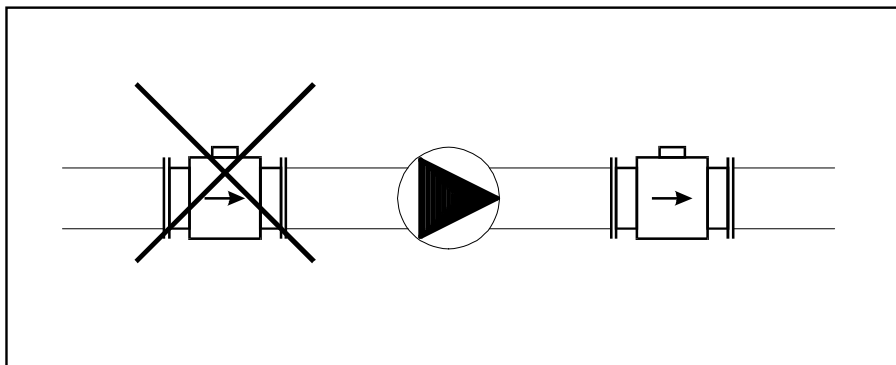

**Valves**

Suitable location of a shutoff valve is downstream of a sensor.

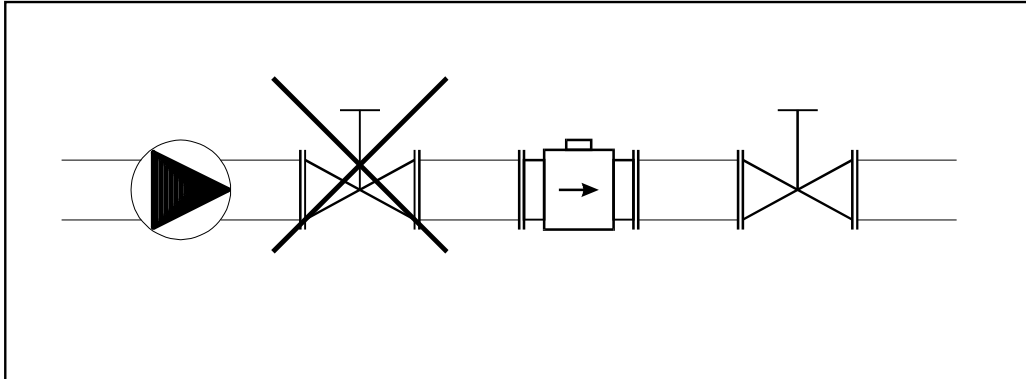

**Removal during maintenance**

If the application requires removal of the sensor for periodic maintenance, it is recommended to install a bypass section as the following drawing.

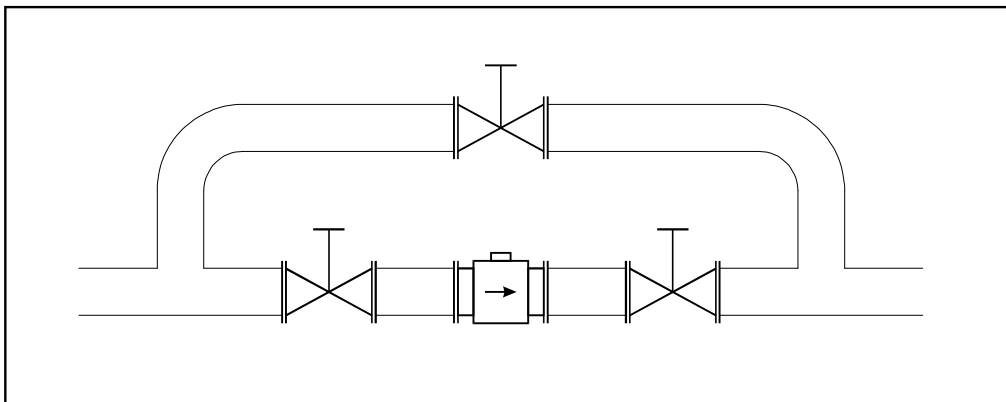

**Vibration**

To avoid mechanical damage protect both electronic unit and sensor against mechanical vibrations. When strong vibrations are possible, both the input and output pipe must be mechanically fixed or the remote version with a separate electronic unit should be used.

**Overheating**

To avoid overheating, the electronic unit should be protected against direct sunlight especially in areas with a warm climate with ambient temperatures over 30 °C. If necessary a sunshade has to be mounted over the electronic unit or a remote version with a separate electronic unit should be used.

## 3.2 Electrical connection

Only a competent person may connect the flowmeter to the mains power supply.

The flowmeter can be connected to the power supply with either a fixed power cable or with a flying lead cable and plug. Cable entries on the electronic unit can be used for flexible electrical cables. Cables with a diameter between 8 and 10 mm must be used to keep protection IP67. It is not recommended to use rigid metal or plastic conduits.

If you use a cable and plug it is recommended that the cable has a cross-section of  $3 \times 1.5\text{mm}^2$  and with a minimum length of 1 m.

In the case of a fixed connection an independent power switch or circuit breaker should be located close to the flowmeter. Cable cross-section as above.

### 3.2.1 Power supply

To connect the compact version to the power supply the following procedure should be used.

- Unscrew the back cover using the special wrench (standard part of delivery).
- Connect the earth wire (yellow-green colour) to the central grounding point inside the case. The end of earth wire must be hooked (app. 3 mm) and fixed to the earth screw.
- Connect Live and Neutral power cables to the power line terminal clamps with labels 14 (L-wire, brown terminal colour) and 13 (N-wire, blue terminal colour).
- Screw on the back cover.
- Switch on the power supply.

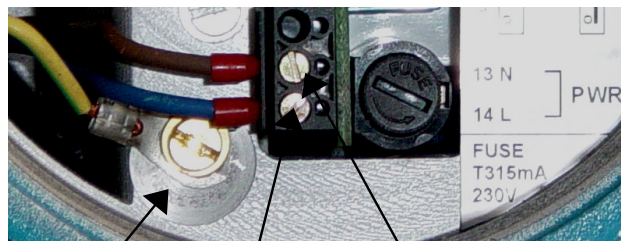

GND central grounding point      L line wire      N line wire

*Note:*

*Be careful to avoid following problems during electrical installation:*

- *Do not cross or loop cables inside electronic unit.*
- *Use separate cable entries for power supply and signal wires.*

### 3.2.2 Electric connection between converter and sensor – Remote version

For remote version converter and flanged sensor are connected with two (2-wire unshielded and 3-wire shielded) cables. Standard length of cables is 6 meter. It is recommended to mount the transmitter not too far from the flanged sensor. Use cables as short as possible.



Five-terminal connector is located in separated box. The same box is used for the converter and also for the sensor. Colours of wires are following:

3-wire shielded cable (shielding is connected to the green wire):

Brown (Blue) : Electrode 1 (EL1)

Green : Ground

White : Electrode 2 (EL2)

2-wire cable:

Brown : Excitation 1 (EXCITATION)

White : Excitation 2 (EXCITATION)

Following procedure should be observed to connect sensor cable to the transmitter or sensor:

- Switch off power supply.
- Dismount top cover of connection box. Four screws must be removed.
- Connect 5 wires (brown (blue), green, white, brown and white) to the connector.
- As the basic protection of connection box is IP65 it is important (in case you need better protection) to fill the box (with connected wires) with neutral silicone. One piece of silicone is standard part of delivery. Using this technology will be protection of transmitter IP67 and protection of sensor IP68.
- Mount the cover back.
- Switch on power supply.

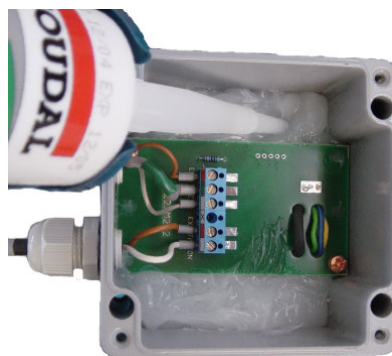

### 3.3 Sensor grounding

To ensure the correct operation of the flowmeter an earthing connection between the sensor and pipeline must be made. The sensor is equipped with screw connection for an earthing wire. This screw has to be connected to the flange on the pipeline. Use Copper wire to connect between the flange and the earth screw on the sensor.

If the pipeline is manufactured from a non-electrically conductive material, or if the pipe is lined with a similar material, special grounding rings must be installed between flanges.

*Note: The flowmeter must not be switched on, if the sensor is not connected /earthed to the rest of pipeline!*

## 4 Electronic unit description

### 4.1 Front panel (display)

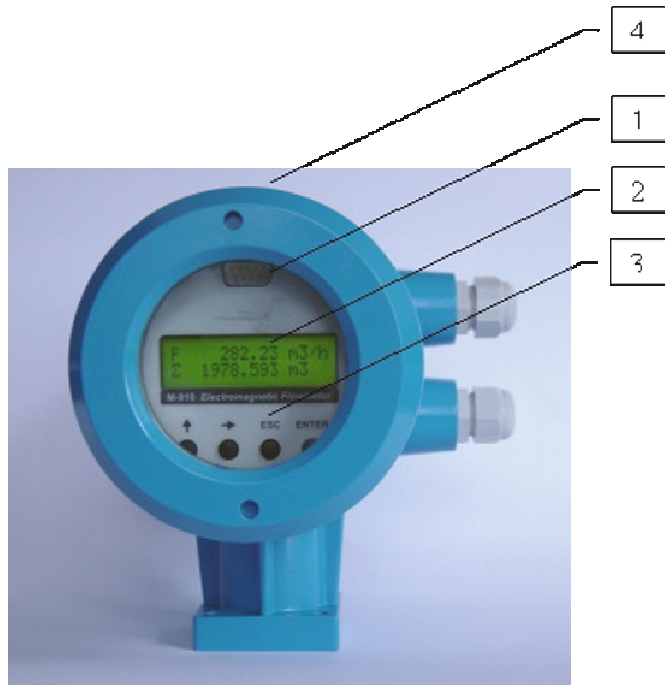

#### 1 RS232 connector

RS232 port enables you to connect the flowmeter to a personal computer. Serial port is galvanically isolated from other electronic circuits.

#### 2 Display

Two-row alphanumerical display is used for displaying all information. The instantaneous flowrate is displayed in upper row. Total volume is displayed in the lower row.

The decimal point position and type of units can be changed in the flowmeter “Setup Menu” (see chapter “Flowmeter configuration”).

#### 3 Keyboard (Mag910 only)

4 keys enable you to change flowmeter configuration and provide flowmeter calibration. These are “UP”, “DOWN”, “ESC” and “ENTER” keys.

#### 4 Magnetic sensor

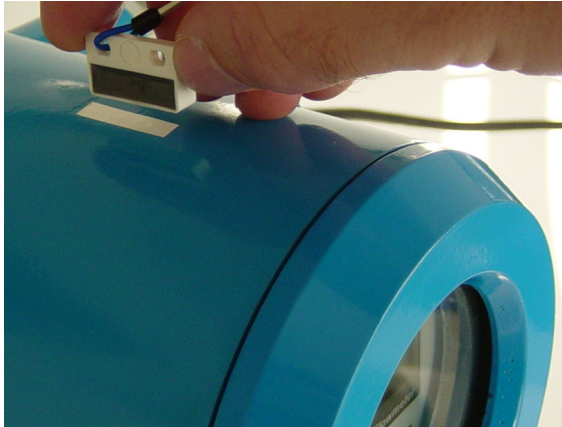

All important displayed information can be read without opening the flowmeter. The sensor display can be activated by using a magnet. Activating the sensor (less than 3 seconds) using a magnet is equal to pushing the “UP” key. Activating the sensor (more than 3 seconds) is equal to pushing “RIGHT” key.

#### 4.2 Rear panel (inputs/outputs)

Under the back cover of the electronic unit are the terminals for input/output signals and supply terminals. The fuse holder is located near the power supply terminals. The top cable gland is for input/output signals cable, bottom cable gland for power supply cable.

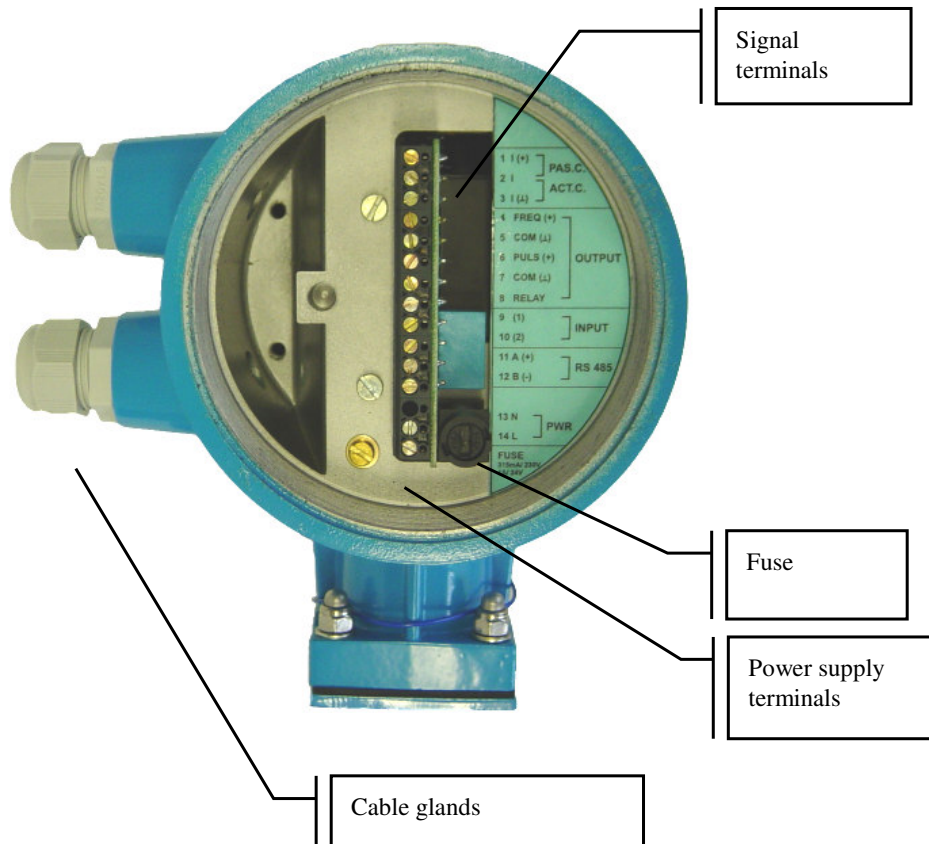

### 4.3 Signal terminals

Current loop

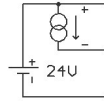

Frequency output



Impulse output



Status output (Mag910 only)

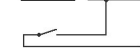

PLC input (Mag910 only)

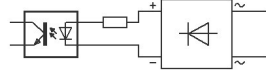

RS485 interface (Mag910 only)

Power supply

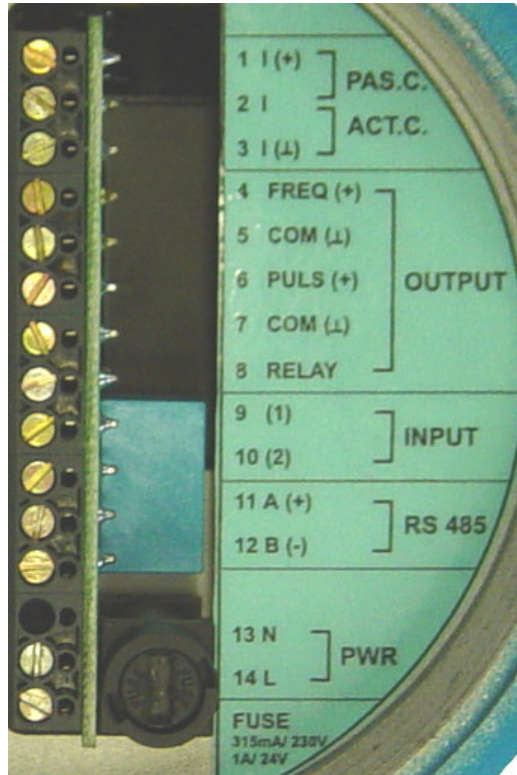

#### 4.3.1 Current loop output

The 4 to 20 mA current loop can be set as a passive type between outputs 1, 2 (1 positive, 2 negative) or as an active type between outputs 2, 3 (2 positive, 3 negative). In both cases the outputs are galvanically isolated from all other electronic circuits of the flowmeter. Voltage drop on passive current loop is 4 V. Active current loop can work to a maximum of 800 Ω.

Example of current output connection:

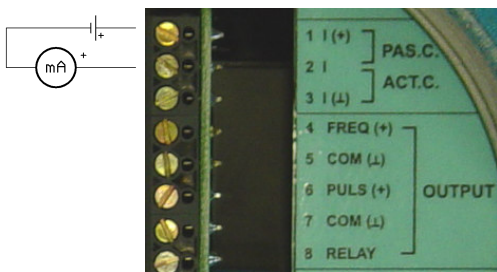

Passive current output connection

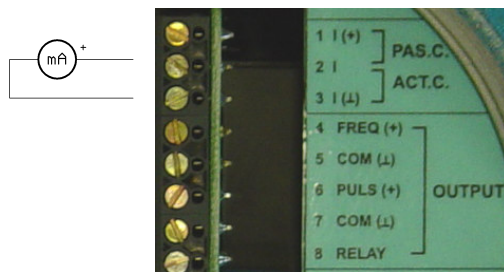

Active current output connection

For more information about current output see chapter “Input and outputs configuration”.



### 4.3.2 Frequency output

The frequency output is a galvanically isolated transistor NPN switch. Voltage drop on the switch is 1 V in the made status. Maximum switched voltage is 50 V. Maximum switched current should not exceed 100 mA. Positive output is on terminal 4, negative output is on terminals 5 and 7 (internally connected). Frequency range of the output is from 0 Hz to 12 kHz.

Example of the frequency output connection:

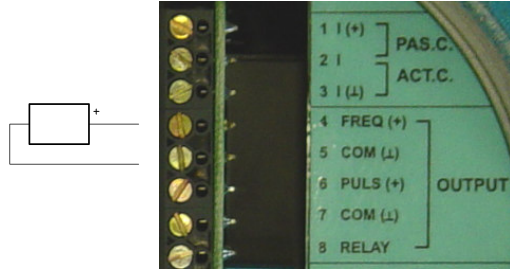

Passive frequency output connection

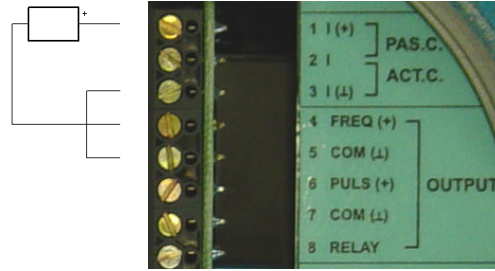

Active frequency output connection

For more information about frequency output see chapter “Input and outputs configuration”.

Note 1: Frequency, impulse and status outputs are galvanically connected to each other and galvanically isolated from other electronic circuits.

Note 2: Active frequency output uses the power supply of the current output. Total current take-off from this power supply (terminal nr. 1) must be less than 40 mA. Active frequency output is galvanically connected to current output.

### 4.3.3 Impulse output

The impulse output is formed by a galvanically isolated transistor NPN switch. Voltage drop on the switch is 1 V in the made mode. Maximum switched voltage is 50 V. Maximum switched current should not exceed 100 mA. Positive output is on terminal 6, negative output is on terminal 5 and 7 (internally connected). Width of the impulse can be set. Maximum frequency of impulse output is limited by impulse width. Maximum frequency is 50 Hz for the shortest impulse 10 ms

Example of impulse output connection:

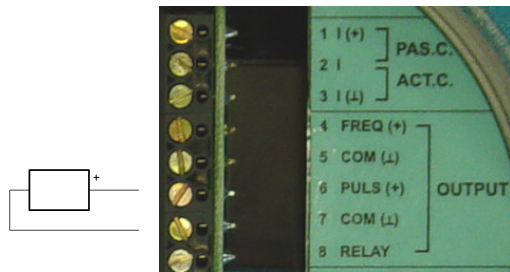

Passive impulse output connection

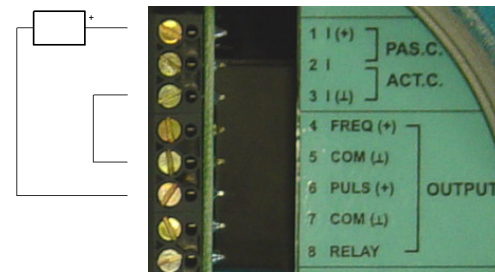

Active impulse output connection

For more information about impulse output see chapter “Input and outputs configuration”.

Note 1: Frequency, impulse and status outputs are galvanically connected to each other and galvanically isolated from other electronic circuits.

Note 2: Active impulse output uses the power supply of the current output. Total current take-off from this power supply (terminal nr. 1) must be less than 40 mA. Active impulse output is galvanically connected to current output.



#### 4.3.4 Status output (Mag910 only)

Status output is formed by relays. Maximum switched voltage is 100 V. Maximum switched current should not exceed 500 mA. First output is on terminal 8, second output is on terminal 5 and 7 (internally connected).

Example of status output connection:

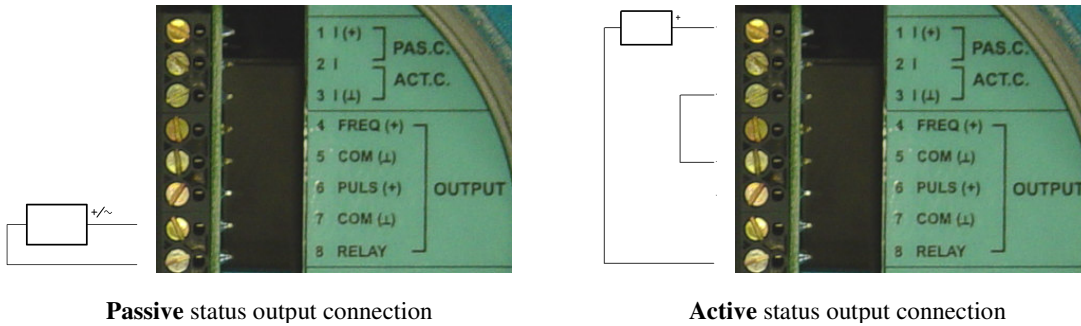

For more information about status output see chapter “Input and outputs configuration”.

*Note 1: Frequency, impulse and status outputs are galvanically connected to each other and galvanically isolated from other electronic circuits.*

*Note 2: Active status output uses the power supply of the current output. Total current take-off from this power supply (terminal nr. 1) must be less than 40 mA. Active status output is galvanically connected to the current output.*

#### 4.3.5 PLC digital input (Mag910 only)

The digital input is activated with a DC voltage between 5 and 30 V (positive or negative). The digital input is between terminals 9 and 10.

For more information about digital input see chapter “Input and outputs configuration”.

*Note: PLC digital input is galvanically isolated from other electronic circuits.*

### 4.3.6 Serial port RS485 (Mag910 only)

The serial port RS485 is assigned for online communication between flowmeter and computer. It is suitable for real time flowmeter monitoring. In contrast to the RS232 serial port, which is suitable for one-shot configuration or calibration of the flowmeter. The RS485 can be connected to up to 16 flowmeters together and the total connection length of all wires can be up to 800 meters. Positive output (A) is on terminal 11, negative output (B) on terminal 12.

#### Example of three flowmeters and one computer interconnection:

All flowmeters and computer are connected parallel using twisted pair cable. At each end of the communications line should be 470  $\Omega$  terminations.

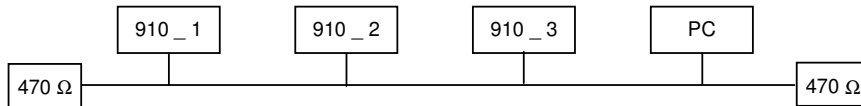

Interconnection of three flowmeters and computer using RS485 bus

Flowmeters are marked with numbers. These numbers are equal to the flowmeters RS485 address.

Program Flow910 is designed for flowmeter control using RS485 or RS232 serial bus.

*Note: Communication through the serial port RS485 is a half duplex type. The flowmeter is a listener and sends data only after a query from a computer. Each flowmeter has its own RS485 address. The range of addresses is 0 to 255. Factory setting of RS485 address is 0. Communication speed is selectable between 4800 and 19200 Bd. For cables over 100m or if there is a noisy power supply voltage (especially peaks generated, usually by motors, etc.), select communication speed below 9600 Bd.*

*Note: Serial port RS485 is galvanically isolated from other electronic circuits.*

#### **4.4 Serial port RS232**

The connector is located on the front panel and is accessible after removing the electronic unit cover. RS232 enables you to connect the flowmeter to a personal computer. RS232 interface is used for flowmeter configuration and calibration. It's not suitable for online communication during operation, because the flowmeter must be open and IP67 protection is not valid. For such communication use RS485 interface.



For connection of the flowmeter to the PC a standard RS232 cable (1 : 1) can be used. To connect a PC to the flowmeter, follow this procedure:

- Unscrew the front cover using the special wrench (standard part of delivery).
- Plug the one end of the RS cable onto the serial connector in the flowmeter.
- Connect the opposite end to the serial port in the PC.
- Use the application software (Flow910) to enter new calibration data or to change settings of the flowmeter.
- Disconnect RS232 cable and replace the cover.

*Note: Serial port RS232 is galvanically isolated from other electronic circuits.*

## 5 Operation

### 5.1 Main menu

The flowmeter is in *Main menu* after the switching power on or after repeatedly pushing the ESC key. This entire menu can be operated with a magnetic without opening the housing. Short use of the magnet (less than 3 seconds) is equal to pushing “UP” key. Longer use of the magnet (more than 3 seconds) is equal to pushing “RIGHT” key.

The following information can be displayed in the *Main Menu*.

Note: Mag910E can be operated by a magnetic pointer only.

#### 5.1.1 Current Flowrate / Total Volume

```
F   120.03 m3/h
Σ  8703.012 m3
```

Basic display (after power on). Current flowrate is displayed on the first line. Total volume is displayed on the second line. Flow in the forward direction is added to this volume, Flow in the reverse direction is subtracted. Measuring parameters (units, resolution, moving average etc.) are selectable in *Setup*

*menu*. After pushing “UP” key “Positive Volume” is displayed.

#### 5.1.2 Positive Volume

```
Positive Volume
Σ+ 8903.012 m3
```

Total volumetric flow in a forward direction. After pushing “UP” key “Negative Volume” is displayed.

#### 5.1.3 Negative Volume

```
Negative Volume
Σ- 220.310 m3
```

Total volumetric flow in the reverse direction. After pushing “UP” key “Auxiliary Volume” is displayed.

#### 5.1.4 Auxiliary Volume

```
Auxiliary Volume
ΣA 5943.942 m3
```

Second Total Volume counter. Can be cleared by pushing “RIGHT” key. It is usually used for measuring volumetric flow during a set period such as day, month etc.. After pushing “UP” key “Maximum Flowrate” is displayed.

#### 5.1.5 Maximum Flowrate / Maximum Flowrate Time (Mag910 only)

```
Hi   620.42 m3/h
07:13 04.03.2003
```

Maximum flowrate value indicated since last reset (pushing “RIGHT” key). Date and time of maximum flowrate is displayed in lower row. After pushing “UP” key “Minimum Flowrate” is displayed.

#### 5.1.6 Maximum Flowrate (Mag910E only)

```
Hi   620.42 m3/h
Maximum Flowrate
```

Maximum flowrate value indicated since last reset (longer use of the magnet).

### 5.1.7 Minimum Flowrate / Minimum Flowrate Time (Mag910 only)

```
Lo    26.20 m3/h
20:42 06.03.2003
```

Minimum flowrate value indicated since last reset (pushing “RIGHT” key). Date and time of minimum flowrate is displayed in lower row. After pushing “UP” key “Datalogger” is displayed.

### 5.1.8 Minimum Flowrate (Mag910E only)

```
Lo    26.20 m3/h
Minimum Flowrate
```

Minimum flowrate value indicated since last reset (longer use of the magnet).

### 5.1.9 Datalogger (Mag910 only)

```
Datalogger    5%
Samples:      723
```

```
20:42 06.03.2003
F    120.03 m3/h
```

Number of samples stored in datalogger and percentage used. Individual samples value can be read after pushing “RIGHT” key. In this submenu samples are read sequentially. Next sample (Flowrate with Date and Time) is displayed after pushing “UP” key. “Sequential reading” submenu is left after pushing “RIGHT” key or after displaying all values. After pushing “UP” key “Current Flowrate / Total Volume” is displayed. Datalogger capacity is more than 10000 samples (typical 15000 samples).

These formats are changed pushing key “UP” or by short activating of the magnet.

## 5.2 Setup menu

**Note: For version Mag910E is the “Setup menu” accessible only using the computer and software Flow910.**

In this menu the flowmeter parameters (measuring, output, communication etc.) can be changed. Access to the *Setup menu* is enabled after pushing the “ENTER” key from the *Main menu*.

*Note: The keyboard is accessible after unscrewing the cover of the electronic unit using the special wrench, which is standard part of delivery.*

Correct password must be entered before entering *Setup menu*. Without correct password the access to the *Setup menu* is

```
Enter Password
[00000]
```

refused. Default factory set password is “00000”. Return to the *Main menu* is possible after pushing the “ESC” key. *Setup menu* has the following structure (items are changed by pushing “UP” key and selected by pushing “ENTER” key):

```
Setup Menu
1 INPUT/OUTPUT
```

#### Setup Menu structure

### 5.2.1 Input and outputs configuration (1 INPUT/OUTPUT)

For the flowmeter outputs and input configuration. After pushing “UP” key next item (“2 FLOWMETER”) is selected. After pushing “ENTER” key following submenu is displayed:

### 5.2.1.1 Current loop output (1.1 CURRENT)

Current loop 4 to 20 mA can be set as passive type between outputs 1, 2 (1 positive, 2 negative) or as active type between outputs 2, 3 (2 positive, 3 negative). In both cases outputs are galvanically separated from all other electronic circuits of the flowmeter. Voltage drop on the passive current loop is 4 V. Active current loop can work to a maximum of 800  $\Omega$ .

Current loop output can be programmed in one of the following modes:

- |                    |  |
|--------------------|--|
| a) <b>Off</b>      | current output is adjusted to 4mA (error message 01 - "Current output" is switched off)  |
| b) <b>Pos.Flow</b> | current $4+16*\text{Flowrate} / \text{QI}$ [mA] is generated for a positive flowrate direction. For a negative flowrate direction 4mA is generated.  |
| c) <b>Neg.Flow</b> | current $4-16*\text{Flowrate} / \text{QI}$ [mA] is generated for a positive flowrate direction. For a positive flowrate direction 4 mA is generated. |
| d) <b>Abs.Flow</b> | current $4+16*\text{abs}(\text{Flowrate}) / \text{QI}$ [mA] is generated for both flowrate directions.   |
| e) <b>Bip.Flow</b> | current $12+8*\text{Flowrate} / \text{QI}$ [mA] is generated for both flowrate directions.   |
| f) <b>Fixed</b>    | current output is adjusted to fixed value (4.000 ... 20.000 mA)  |

QI value represents a flowrate for a current of 20 mA and can be set independently to the nominal diameter of the sensor. QI value can be changed in "Setup mode" after selecting modes "b", "c", "d" or "e". Fixed current value can be changed in "Setup mode" after selecting mode "f". Following values are pre-set:

#### Current loop standard factory setting:

**Mode** „Positive flowrate“.

**QI** flowrate corresponds to maximum required nominal flowrate  $Q_N$

### 5.2.1.2 Frequency output (1.2 OUTPUT F)

Frequency output is a galvanically isolated transistor NPN switch. Voltage drop on the switch is 1 V in the made status. Maximum switched voltage is 50 V. Maximum switched current should not exceed 100 mA. Positive output is on terminal 4, negative output is on terminals 5 and 7 (internally connected). Frequency range of the output is from 0 Hz to 12 kHz.

The frequency output can be programmed in one of following modes:

- |                    |  |
|--------------------|--|
| a) <b>Off</b>      | output is not active (off state).  |
| b) <b>Pos.Flow</b> | frequency $1000*\text{Flowrate}/\text{QF}$ [Hz] is generated for positive flowrate direction.          |
| c) <b>Neg.Flow</b> | frequency $-1000*\text{Flowrate}/\text{QF}$ [Hz] is generated for negative flowrate direction.         |
| d) <b>Abs.Flow</b> | frequency $1000*\text{abs}(\text{Flowrate})/\text{QF}$ [Hz] is generated for both flowrate directions. |
| e) <b>On Pos.</b>  | output is off in case of negative flow and made in case of positive flow.                              |
| f) <b>On Neg.</b>  | output is off in case of positive flow and made in case of negative flow.                              |
| g) <b>On In</b>    | output is on, when flowrate is higher than PF1 and lower than PF2, otherwise it is off.                |
| h) <b>On Out</b>   | output is off, when flowrate is higher than PF1 and lower than PF2, otherwise it is on.                |
| i) <b>Dose On</b>  | output is on, when programmed dose is counting, otherwise it is off.                                   |
| j) <b>Dose Off</b> | output is off, when programmed dose is counting, otherwise it is on.                                   |
| k) <b>On&lt;F2</b> | output is on, when flowrate is lower than PF2, otherwise it is off.                                    |
| l) <b>On&gt;F2</b> | output is on, when flowrate is higher than PF2, otherwise it is off.                                   |
| m) <b>Fixed</b>    | frequency output is adjusted to fixed value (10 ... 12000 Hz)  |

If setting the flow limit is chosen, hysteresis H can be set too. Hysteresis is a tolerance field on one side of flow limits PF1 and PF2. The output status changes (indicates crossing over the pre-set limit), when the immediate flowrate crosses over the value PF2 (or goes below limit PF1). The output status comes back to the default status, when the immediate flowrate decreases under the value PF2-H (or increases over limit PF1+H) again.

Mode g ) with non-zero hysteresis:



Mode h) with non-zero hysteresis:



Mode k) with non-zero hysteresis:

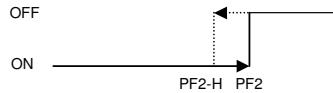

Mode l) with non-zero hysteresis:

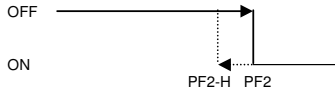

QF value represents flowrate for frequency 1000 Hz and can be set independently to the nominal diameter of the sensor. QF value can be changed after selecting modes “b”, “c” or “d”. Fixed frequency value can be changed after selecting mode “m”. Following values are pre-set:

**Frequency output standard factory setting:**

- Mode** „Positive flowrate“.
- QF** flowrate corresponds to the required nominal flowrate  $Q_N$
- PF1** limit corresponds to the required nominal flowrate  $-Q_N$
- PF2** limit corresponds to the required nominal flowrate  $Q_N$
- H** hysteresis corresponds to the required nominal flowrate  $Q_N/10$

Parameters PF1, PF2 and H are common for frequency, impulse and status mode.

**5.2.1.3 Impulse output (1.3 OUTPUT P)**

Impulse output is formed by a galvanically isolated transistor NPN switch. Voltage drop on the switch is 1 V in the made mode. Maximum switched voltage is 50 V. Maximum switched current should not exceed 100 mA. Positive output is on terminal 6, negative output is on terminal 5 and 7 (internally connected). Width of the impulse can be set. Maximum frequency of impulse output is limited by the impulse width. For the shortest impulse 10 ms is maximal frequency 50 Hz.

Impulse output can be programmed in one of the following modes:

- a) **Off** output is not active (off state).
- b) **Pos.Flow** 1 impulse is generated when total volume QP of liquid has flowed in a positive direction.
- c) **Neg.Flow** 1 impulse is generated when total volume QP of liquid has flowed in a negative direction.
- d) **Abs.Flow** 1 impulse is generated when total volume QP of liquid has flowed in a negative or positive direction.
- e) **On Pos** output is off in case of negative flow and made in case of positive flow.
- f) **On Neg** output is off in case of positive flow and made in case of negative flow.
- g) **On In** output is on, when flowrate is higher than PF1 and lower than PF2, otherwise it is off.
- h) **On Out** output is off, when flowrate is higher than PF1 and lower than PF2, otherwise it is on.
- i) **Dose On** output is on, when programmed dose is counting, otherwise it is off.
- j) **Dose Off** output is off, when programmed dose is counting, otherwise it is on.
- k) **On>F1** output is on, when flowrate is higher than PF1, otherwise it is off.
- l) **On<F1** output is on, when flowrate is lower than PF1, otherwise it is off.

If setting of flow limit is chosen, hysteresis H can be set too. Hysteresis is a tolerance field on one side of flow limits PF1 and PF2. The output status changes (indicates crossing over pre-set limit), when the immediate flowrate crosses over the value PF2 (or goes below limit PF1). The output status comes back to the default status, when the immediate flowrate decreases under the value PF2-H (or increases over limit PF1+H) again.

Mode g) with non-zero hysteresis:

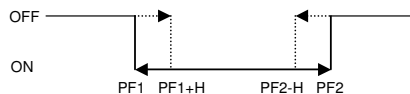

Mode h) with non-zero hysteresis:

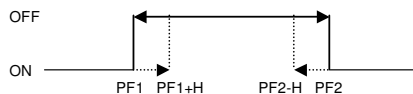

Mode k) with non-zero hysteresis:

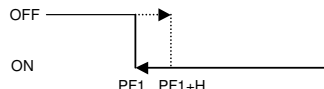

Mode l) with non-zero hysteresis:

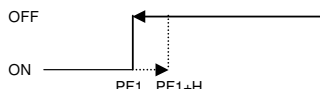

QP value represents volume for 1 impulse and can be set independently to the nominal diameter of sensor. QP value can be changed after selecting modes “b”, “c” or “d”. Following values are pre-set:

#### Impulse output standard factory setting:

|             |  |
|-------------|--|
| <b>Mode</b> | „Positive flowrate“.   |
| <b>QP</b>   | 1000 litres  |
| <b>PF1</b>  | limit corresponds to the required nominal flowrate $-Q_N$        |
| <b>PF2</b>  | limit corresponds to the required nominal flowrate $Q_N$         |
| <b>H</b>    | hysteresis corresponds to the required nominal flowrate $Q_N/10$ |

Parameters PF1, PF2 and H are common for frequency, impulse and status mode.

#### 5.2.1.4 Pulse width (1.4 PULSE WIDTH)

Function enables to change the pulse width of “Impulse Output” in milliseconds after pressing key “ENTER”. With keys “UP” and “RIGHT” any value between 10 millisecond and 2500 milliseconds can be set. To change the currently valid value to the new value press the key “ENTER”. Key “ESC” discards changes.

*Note: Pulse width can be set with 10 ms resolution (values 10, 20, 30, ...).*

Following values are pre-set:

#### Pulse width standard factory setting:

**Pulse width** 100 milliseconds

#### 5.2.1.5 Status output (1.5 OUTPUT S) (Mag910 only)

Status output is formed by relays. Maximum switched voltage is 100 V. Maximum switched current should not exceed 500 mA. First output is on terminal 8, second output is on terminals 5 and 7 (internally connected).

Status output can be programmed in one of the following modes:

- |                   |   |
|-------------------|---|
| a) <b>Off</b>     | output is not active (off state).   |
| b) <b>On Pos.</b> | output is off in case of negative flow and made in case of positive flow.               |
| c) <b>On Neg.</b> | output is off in case of positive flow and made in case of negative flow.               |
| d) <b>On In</b>   | output is on, when flowrate is higher than PF1 and lower than PF2, otherwise it is off. |
| e) <b>On Out</b>  | output is off, when flowrate is higher than PF1 and lower than PF2, otherwise it is on. |
| f) <b>Dose On</b> | output is on, when programmed dose is counting, otherwise it is off.                    |



- g) **Dose Off**                      output is off, when programmed dose is counting, otherwise it is on.
- h) **On>F1**                        output is on, when flowrate is higher than PF1, otherwise it is off.
- i) **On<F1**                        output is on, when flowrate is lower than PF1, otherwise it is off.

If setting of flow limit is chosen, hysteresis H can be set too. Hysteresis is a tolerance field on one side of flow limits PF1 and PF2. The output status changes (indicates crossing over pre-set limit), when the immediate flowrate crosses over the value PF2 (or goes below limit PF1). The output status comes back to the default status, when the immediate flowrate decreases under the value PF2-H (or increases over limit PF1+H) again.

Mode d) with non-zero hysteresis:



Mode e) with non-zero hysteresis:



Mode h) with non-zero hysteresis:

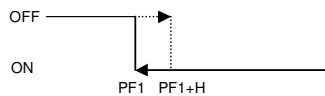

Mode i) with non-zero hysteresis:

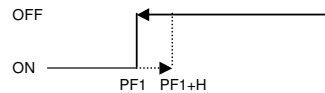

Following values are pre-set:

**Status output standard factory setting:**

- Mode**    „Off“.
- PF1**    limit corresponds to the required nominal flowrate  $-Q_N$
- PF2**    limit corresponds to the required nominal flowrate  $Q_N$
- H**        hysteresis corresponds to the required nominal flowrate  $Q_N/10$

Parameters PF1, PF2 and H are common for frequency, impulse and status mode.

**5.2.1.6 PLC digital input (1.6 INPUT) (Mag910 only)**

Digital input is activated with DC voltage between 5 and 30 V (positive or negative). Digital input is between terminals 9 and 10.

Digital input can be programmed in one of the following modes:

- a) **Off**                                input is not active.
- b) **Dose**                            input activation starts dose QD measuring. Dosing indication can be performed by one of outputs (frequency, impulse or status).
- c) **Clr.Vol**                        input activation clears the Auxiliary volume.

QD value represents volume for dosing. QD value can be changed after selecting mode “b”.

Following values are pre-set:

**Digital input standard factory setting:**

**QD** volume 1000 l

**Mode** „Off“.

**5.2.1.7 Low flowrate limit (1.7 LIMIT PF1)**

Function enables you to set low flowrate limit for some functions of digital outputs after pressing “ENTER” key. See “Frequency output”, “Impulse output” and “Status output”. With the “UP” and “RIGHT” keys any value between +/-  $Q_{MAX}$  flowrate can be set. Limit PF1 is displayed in the same format as the flowrate. To change the current valid value to the new value press the “ENTER” key. “ESC” key discards changes.

Following values are pre-set:

**Low flowrate limit standard factory setting:**

**PF1** limit corresponds to the required nominal flowrate  $-Q_N$

**5.2.1.8 High flowrate limit (1.8 LIMIT PF2)**

Function enables you to set high flowrate limit for some functions of digital outputs after pressing key “ENTER”. See “Frequency output”, “Impulse output” and “Status output”. With the “UP” and “RIGHT” keys any value between +/-  $Q_{MAX}$  flowrate can be set. Limit PF2 is displayed in the same format as the flowrate. To change the current valid value to the new value press the “ENTER” key. “ESC” key discards changes.

Following values are pre-set:

**High flowrate limit standard factory setting:**

**PF2** limit corresponds to the required nominal flowrate  $Q_N$

**5.2.1.9 Hysteresis of flowrate limits (1.9 HYSTERESIS)**

Function enables you to set hysteresis of limit values for some functions of digital outputs after pressing key “ENTER”. See “Frequency output”, “Impulse output” and “Status output”. With the “UP” and “RIGHT” keys any value between +/-  $Q_{MAX}$  flowrate can be set. Hysteresis is displayed in the same format as the flowrate. To change the current valid value to the new value press the “ENTER” key. “ESC” key discards changes.

Following values are pre-set:

**Hysteresis standard factory setting:**

**H** limit corresponds to the required nominal flowrate  $Q_N/10$

**5.2.1.10 RS485 baud rate (1.A RS485 B.R.) (Mag910 only)**

Function enables you to set parameter baud rate of RS485 interface after pressing “ENTER” key. With the “UP” key any value from the row 4800, 9600 or 19200 Bd can be set. To change the current valid value to the new value press the “ENTER” key. “ESC” key discards changes.

Following values are pre-set:

**Baud rate standard factory setting:**

**Baud Rate** 9600 Bd.

### 5.2.1.11 RS485 address (1.B RS485 ADDR.) (Mag910 only)

Function enables to set parameter address of RS485 interface after pressing “ENTER” key. With the “UP” and “RIGHT” keys any value between 0 and 255 can be set. To change the current valid value to the new value press the “ENTER” key. “ESC” key discards changes.

Following values are pre-set:

#### **Baud rate standard factory setting:**

**ADDR** 00.

*Note: RS485 address is important in case of connecting more flowmeters to common RS485 bus. Each flowmeter has its own RS485 address. The connected computer can control communication between these flowmeters using their addresses. Communication will be excluded in case of two equal addresses.*

### 5.2.2 Flowmeter configuration (2 FLOWMETER)

For flowmeter parameters configuration. After pushing “UP” key next item (“3 GENERAL”) is selected. After pushing “ENTER” key following submenu is displayed:

#### 5.2.2.1 Flowrate units (2.1 FLOW UNIT)

Function enables you to set flowrate units after pressing the “ENTER” key. With the “UP” key any item from the list “l/s”, “m<sup>3</sup>/h”, “G/m” and “user” can be set. To change the current valid unit to the selected unit press the “ENTER” key. “ESC” key discards changes.

Available units:

|                   |  |
|-------------------|--|
| l/s               | litres per second  |
| m <sup>3</sup> /h | cubic metres per hour  |
| G/m               | US gallons per minute  |
| user              | user-defined unit, factory-set is „l/h“ (litres per hour), user defined unit can be changed by computer only |

Following values are pre-set:

#### **Flowrate units standard factory setting:**

**Flowrate units** m<sup>3</sup>/h

**User** l/h

#### 5.2.2.2 Flowrate resolution (2.2 FLOW RESOL.)

Function enables you to set flowrate resolution after pressing the “ENTER” key. With the “UP” key any item from the list “0”, “0.0”, “0.00”, “0.000” and “0.0000” can be set. To change the current valid resolution to the selected resolution press the “ENTER” key. “ESC” key discards changes.

Available resolution:

|        |                        |
|--------|------------------------|
| 0      | without decimal digits |
| 0.0    | max. 1 decimal digit   |
| 0.00   | max. 2 decimal digits  |
| 0.000  | max. 3 decimal digits  |
| 0.0000 | max. 4 decimal digits  |

*Note: selected resolution is the maximal resolution. It is reduced for high values. For example 4 decimal digits resolution is valid up to -99.9999 or 99.9999 displayed value. For higher values, the resolution reduced (999.999).*

Following values are pre-set:

#### **Flowrate resolution standard factory setting:**

**Resolution** 0.0000 for  $Q_{100\%} < 3.0000$   
0.000 for  $3.000 \leq Q_{100\%} < 30.000$

0.00 for  $30.00 \leq Q_{100\%} < 300.00$   
 0.0 for  $300.0 \leq Q_{100\%} < 3000.0$   
 0 for  $Q_{100\%} \geq 3000.0$

### 5.2.2.3 Volume units (2.3 VOLUME UNIT)

Function enables to set volume units after pressing the “ENTER” key. With the “UP” key any item from the list “m3”, “l”, “US.G” and “user” can be set. To change the current valid unit to the selected unit press the “ENTER” key. “ESC” key discards changes.

Available units:

m3 cubic metres

l litres

US.G US gallons

user user-defined unit, factory-set is „l“ (litres), user defined unit can be changed by computer only

Following values are pre-set:

#### Volume units standard factory setting:

Volume units m3

User 1

### 5.2.2.4 Volume resolution (2.4 VOL. RESOL.)

Function enables to set volume resolution after pressing the “ENTER” key. With the “UP” key any item from the list “0”, “0.0”, “0.00”, “0.000” and , “0.0000” can be set. To change the current valid resolution to the selected resolution press the “ENTER” key. “ESC” key discards changes.

Available resolution:

0 without decimal digits

0.0 max. 1 decimal digit

0.00 max. 2 decimal digits

0.000 max. 3 decimal digits

0.0000 max. 4 decimal digits

*Note:* selected resolution is the maximuml resolution. It is reduced for high values. For example 4 decimal digits resolution is valid up to -999.9999 or 9999.9999 displayed value. For higher values the resolution is reduced (99999.999).

Following values are pre-set:

#### Volume resolution standard factory setting:

Resolution 0.000

### 5.2.2.5 Flowrate direction (2.5 FLOW DIREC.)

Function enables you to switch between “Positive” and “Negative” flow direction (change the sign in flowrate value) after pressing the “ENTER” key. With the “UP” key any item from the list “Positive” and , “Negative” can be set. To change the current valid direction to the selected direction press the “ENTER” key. “ESC” key discards changes.

*Note:* flowmeters are working in both flow directions, however they are calibrated for positive direction only.

Following values are pre-set:

#### Flowrate direction standard factory setting:

Flow direc. Positive

#### 5.2.2.6 Low-flow cutoff (2.6 L.F.CUTOFF)

Function enables you to set limit for suppressing low flowrates after pressing “ENTER” key. With the “UP” key and “RIGHT” any value between +/-  $Q_{MAX}$  flowrate can be set. Limit is displayed in the same format as the flowrate. To change the current valid value to the new value press the “ENTER” key. “ESC” key discards changes.

*Note:* All flowrates below this value will be displayed as 0.00. This setting is valid for display and all outputs.

Following values are pre-set:

**Low-flow cutoff standard factory setting:**

**L.F.Cutoff** corresponds to the flowrate  $Q_{1\%}/2$  (see table 2 M910 Flowrates)

#### 5.2.2.7 Moving average time constant (2.7 TIMECONST)

Function enables you to change the time for moving average calculating after pressing “ENTER” key. With “UP” and “RIGHT” key any value between 1 second and 20 seconds can be set. To change the current valid value to the new value press the “ENTER” key. “ESC” key discards changes.

Following values are pre-set:

**Time constant standard factory setting:**

**Timeconst** 10 seconds

#### 5.2.2.8 Time setting (2.8 TIME SET.) (Mag910 only)

Function enables you to correct time of internal Real time clock after pressing “ENTER” key. With “UP” and “RIGHT” key any time between 00:00:00 and 23:59:59 can be set. To change the current valid value to the new value press the “ENTER” key. “ESC” key discards changes.

Following values are pre-set:

**Time setting standard factory setting:**

**Time set.** Central European Time

#### 5.2.2.9 Date setting (2.9 DATE SET.) (Mag910 only)

Function enables you to correct date of internal Real time clock after pressing key “ENTER” key. With “UP” and “RIGHT” key any date between 01.01.2000 and 31.12.2099 can be set. To change the current valid value to the new value press the “ENTER” key. “ESC” key discards changes.

Following values are pre-set:

**Date setting standard factory setting:**

**Date set.** Actual date

#### 5.2.2.10 Datalogger setting (2.A DATALOGGER) (Mag910 only)

Function enables you to set sample interval for internal datalogger after pressing “ENTER” key. With “UP” key any value from the row OFF, 5, 10, 15, 30, 45, 60, 120, 180, 240 and CLR can be select. To change the current valid value to the new value press the “ENTER” key. “ESC” key discards changes. Datalogger will be cleared after selection item CLR. This selection doesn't change datalogger sample interval.

Following values are pre-set:

**Datalogger standard factory setting:**

**Datalogger** OFF

### 5.2.3 General settings (3 GENERAL)

For general settings configuration or for reading actual settings. After pushing “UP” key next item is selected. After pushing “ENTER” key following submenu is displayed:

#### 5.2.3.1 Diameter (3.1 DIAMETER)

Flowmeters nominal diameter is displayed. After pushing “UP” key “Range” is displayed.

#### 5.2.3.2 Nominal flowrate range $Q_N$ (3.2 RANGE)

Nominal flowrate range  $Q_N$  is displayed in flowrate units. After pushing “UP” key “Serial number” is displayed.

#### 5.2.3.3 Serial number (3.3 SERIAL NR.)

Flowmeters Serial number is displayed. After pushing “UP” key “Power supply” is displayed.

#### 5.2.3.4 Power supply (3.4 POWER SUP.)

Information about power supply (voltage and frequency) is displayed. After pushing “UP” key “Self test” is displayed.

#### 5.2.3.5 Self-test (3.5 SELFTEST)

Function enables you to switch an internal self-test (flowrate simulator) “On” or “Off” after pressing “ENTER” key. With “UP” key any item from the list “On” and, “Off” can be set. To change the current valid self-test state press the “ENTER” key. “ESC” discards changes.

*Note: Self-test “Off” state is normal working state of flowmeter. After switching self-test to “On” state, internal flowrate simulator is inserted instead of the pipe. Function can be used for signal converter testing. . Number in range (0.980, 1.020) is displayed, if signal converter is OK. Number is displayed in state “On” only. After switching on you have to wait for converter stabilization (up to 20 seconds).*

Following values are pre-set:

**Self-test standard factory setting:**

Self-test            Off

#### 5.2.3.6 Current Loop Test (3.6 C.LOOP TEST)

Function enables you to switch an internal test of the connected current loop “On” or “Off” after pressing the “ENTER” key. With the “UP” key any item from the list “On” and, “Off” can be set. To change the current valid Current Loop Test state press the “ENTER” key. “ESC” key discards changes.

*Note: If Current Loop Test is in “On” state and current output flows less than 3 mA, error message “01 – Current Output” will be displayed.*

Following values are pre-set:

**Current Loop Test standard factory setting:**

C.Loop Test        Off

### 5.2.3.7 Basic Menu Password (3.7 PASSWORD MN.)

Function enables you to enter a new password for basic menu access after pressing the ENTER key. With the “Up” and “Right” key any password in range between 00000 and 99999 can be set. To change the current valid password to the new password press the ENTER key. ESC key discards changes.

Following values are pre-set:

**Basic Menu Password standard factory setting:**  
PASSWORD MN. 00000

### 5.2.4 Calibration menu (4 CALIBRATION)

**Setting any new value in calibration menu changes calibration data! Calibration should be performed in an appropriate equipped laboratory.**

**We recommended using software Flow910 for easy Calibration. It contains „calibration wizard“ and can prevent flowmeter from incorrect calibration.**

*Calibration menu* is accessible as part 4 of the *Setup menu*, if the correct calibration password has been entered. After entering the *Basic menu password* only parts 1 to 3 of *Setup menu* are accessible. Without the correct password access to the *Calibration menu* is refused. Default factory set Calibration password is “10000”.

*Note:* Flowmeter Mag910 enables calibration at 2, 3 or 4 points. Each calibration point contains 2 values. Nominal value of calibration point is selected by user in range between  $\pm Q_{MAX}$  (for maximum flowrates see table 1: M910 flowrates). It is expressed in flowrate units. To this nominal value is attached a calibration constant. Calibration constant doesn't have a unit. In the calibration process you change this calibration constant to reach similarity between standard flowmeter and the calibrated flowmeter. Higher calibration constant means lower displayed value. Calibration constants must be different. In the case of two equal calibration constants, the measured values could be wrong.

#### 5.2.4.1 Number of Calibration Points (4.1 NR.OF CALP.)

Function enables you to enter a new number of calibration points after pressing the ENTER key. With the “Up” and “Right” keys any number in range between 2 and 4 can be set. To change the current valid number to the new number press the ENTER key. ESC key discards changes.

*Note:* Standard number of calibration points is 2. More calibration points are used for special applications when higher accuracy is expected (negative flowrate, low flowrates etc.).

Following values are pre-set:

**Number of Calibration Points standard factory setting:**  
NR.OF CALP. 2

#### 5.2.4.2 Calibration point 1 (4.2 CAL.POINT 1)

Function enables you to change nominal and calibration value of Calibration point 1 after pressing the “ENTER” key. With the “UP” and “RIGHT” keys any value in the range of real flowrates can be set. To change the current valid nominal value to the new nominal value press the “ENTER” key. After entering the nominal value a new calibration constant can be set. “ESC” key discards changes.

Following values are pre-set:

**Calibration point 1 standard factory setting:**

**Nominal point** 5 ... 10% of required  $Q_N$   
**Cal. Constant** is assigned according to the calibration

**5.2.4.3 Calibration point 2 (4.3 CAL.POINT 2)**

Function enables you to change the nominal and calibration value of Calibration point 2 after pressing the "ENTER" key. With "UP" and "RIGHT" key any value in the range of real flowrates can be set. To change the current valid nominal value to the new nominal value press the "ENTER" key. After entering the nominal value new calibration constant can be set. "ESC" key discards changes.

Following values are pre-set:

**Calibration point 2 standard factory setting:**

**Nominal point** 40 ... 70% of required  $Q_N$   
**Cal. Constant** is assigned according to the calibration

**5.2.4.4 Calibration point 3 (4.4 CAL.POINT 3)**

Function is available only if 3 or 4 calibration points are selected. Function enables you to change the nominal and calibration value of Calibration point 3 after pressing the "ENTER" key. With the "UP" and "RIGHT" key any value in the range of real flowrates can be set. To change the current valid nominal value to the new nominal value press the "ENTER" key. After entering the nominal value a new calibration constant can be set. "ESC" key discards changes.

Following values are pre-set:

**Calibration point 3 standard factory setting:**

**Not used.**

**5.2.4.5 Calibration point 4 (4.5 CAL.POINT 4)**

Function is available only if 4 calibration points are selected. Function enables you to change the nominal and calibration value of Calibration point 4 after pressing the "ENTER" key. With the "UP" and "RIGHT" keys any value in the range of real flowrates can be set. To change the current valid nominal value to the new nominal value press the "ENTER" key. After entering the nominal value a new calibration constant can be set. "ESC" key discards changes.

Following values are pre-set:

**Calibration point 4 standard factory setting:**

**Not used.**

**5.2.4.6 Calibration Password (4.6 PASSWORD CA.)**

Function enables you to enter a new password for calibration menu access after pressing the "ENTER" key. With the "UP" and "RIGHT" keys any password in the range between 00000 and 99999 can be set. To change the current valid password to the new password press the "ENTER" key. "ESC" key discards changes.

Following values are pre-set:

**Calibration Password standard factory setting:**

**PASSWORD CA.** 10000

**5.2.5 Service configuration (5 SERVICE)**

For the flowmeter service configuration. Available only for authorized service department, if the correct service password has been entered.



## 6 Error messages

When any error occurs, the flowmeter will display an error message. Errors can arise because of:

- Incorrect control, i.e. faulty connection to the flowmeter, grounding, etc.,
- Flowmeter failure

Error 45  
Excitation Err.

In case of any error, the error message is displayed on the display for approx. 1 second.

After switching on, an internal test of the hardware is performed. If there were any errors during the test, the flowmeter would display the appropriate error message.

Types of errors and methods of troubleshooting (if available) are in following table.

| Nr | Error                          | Meaning  | Troubleshooting  |
|----|--------------------------------|--|--|
| 01 | Current output                 | Current loop is disconnected.  | Connect the current output or switch the current output OFF (if it is not used). This message can be disabled in "Setup menu". |
| 20 | Wrong password (Mag910 only)   | Wrong password for setup / calibration / service menu was used.        | Use correct password.  |
| 21 | Not a number (Mag910 only)     | Non numerical value  | Write the appropriate number.  |
| 22 | Value too low (Mag910 only)    | Entry value is to low  | Write the appropriate number.  |
| 23 | Value too high (Mag910 only)   | Entry value is to high   | Write the appropriate number.  |
| 24 | Wrong format (Mag910 only)     | Bad date or time format  | Write regular date or time format.   |
| 25 | Datalogger empty (Mag910 only) | No records in datalogger   | Datalogger is switched OFF or records have been cleared.   |
| 26 | Wrong Cal. Point (Mag910 only) | There are 2 or more calibration constants with the same nominal value. | Correct calibration constant values or reduce number of calibration points.  |
| 31 | RS232 Frame Err.               | Valid stop bit missing   | Communication format RS232 is wrong. Check the Baud rate (1200 Bd).  |
| 45 | Excitation Err.                | Excitation coils error   | Excitation is not working properly. Contact service department.  |
| 46 | Empty pipe                     | No liquid in pipe  | Fill the pipe with liquid.   |

## 7 Maintenance

The inductive flowmeter is an electronic device with circuits protected with built-in electronic fuses. These protect the instrument against damage caused by the user.

### 7.1 Advice for correct operation

The following principles should be considered during installation:

- *If there is a noisy power supply voltage (especially peaks generated, usually by motors, etc.), use an external power supply filter between the flowmeter and power supply.*
- *Protect the flowmeter and the internal lining of the sensor pipe from mechanical damage, especially during installation or cleaning.*
- *Protect the flowmeter from direct sunlight. Fit a sunshade if necessary.*
- *Do not expose the flowmeter to intense vibration.*

### 7.2 Periodical maintenance

The flowmeter does not require any special maintenance. Dependent on the media being measured it is recommended that approx. once a year, remove the sensor from the pipe and clean the liner. Method of cleaning consists of removing mechanical dirt and any non-conductive coating (like oil film) from the liner. A very dirty liner could cause inaccuracy of the measurement. Check mechanical state of the liner.

### 7.3 What to do in case of failure

If an **obvious failure** occurs during the operation (e.g. the display is not lit), the flowmeter must be switched off immediately. First, check the fuse located under the electronic board cover.

- Turn off the power to the flowmeter.
- Remove the cover from the transmitter
- The fuse holder is located behind the power supply terminals. Remove the fuse. Replace it with a new fuse of the same rating if necessary
- Replace the cover.
- Connect power supply again.

If an obvious fault is evident, e.g. a measurement range or an operating mode is not functional, the user cannot correct the fault. Contact Arkon.

**Hidden faults** can cause different symptoms. Usually, they cause instability of some parameters. Hidden defects can be caused by unacceptable distortion, degraded insulation etc. In this case contact Arkon.

The flowmeter can have “hidden defects”, when correct operation rules are not applied. In this case, the fault can be caused by wrong installation. Most frequent cases of false “hidden defects”:

- mains voltage out of tolerance limits or unstable
- poor grounding of the measuring circuit (bad connection of the ground terminal )
- large electrostatic or electromagnetic field.

## 8 Application information

### 8.1 Weight and dimensions

Flowmeter weight and dimensions depend mostly on the version (remote or compact) and diameter of the pipe.

#### 8.1.1 Electronic unit – compact version

The pictures below show dimensions of the electronic unit for the compact version. Dimensions are in millimetres.

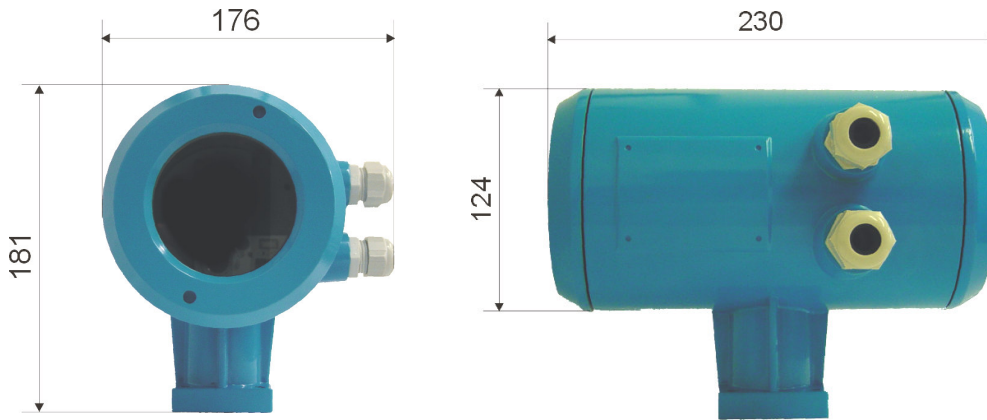

Weight: 3.8 kg

#### 8.1.2 Electronic unit – remote version

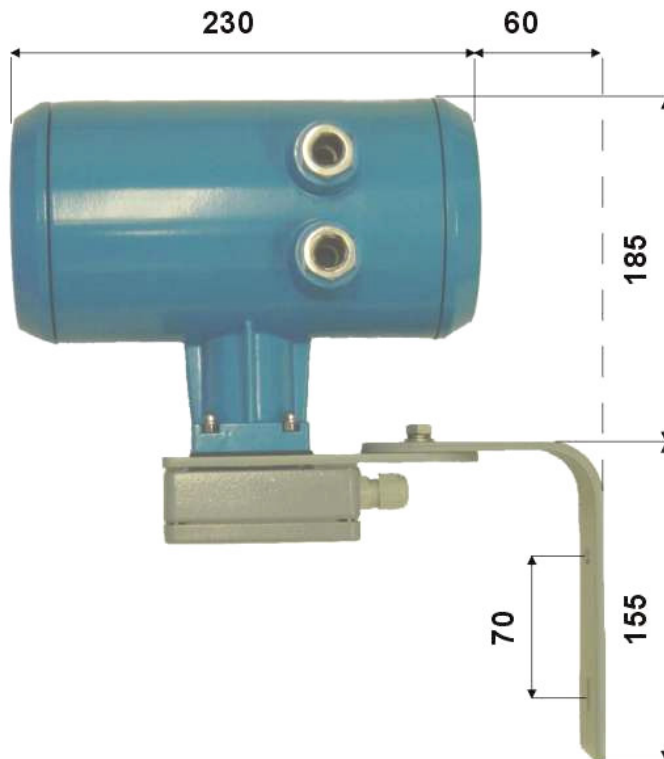

The picture shows dimensions of the electronic unit for the compact version. Dimensions are in millimetres.

Weight: 5.1 kg

### 8.1.3 Sensor

In the table below are the dimensions of the sensor for compact version. In case of remote version add 120 millimetres to dimension “A” for cable gland and cable. Flanges in DIN version meet standard EN1092. Flanges in ANSI version meet requirements of ANSI B 16.5 standard.

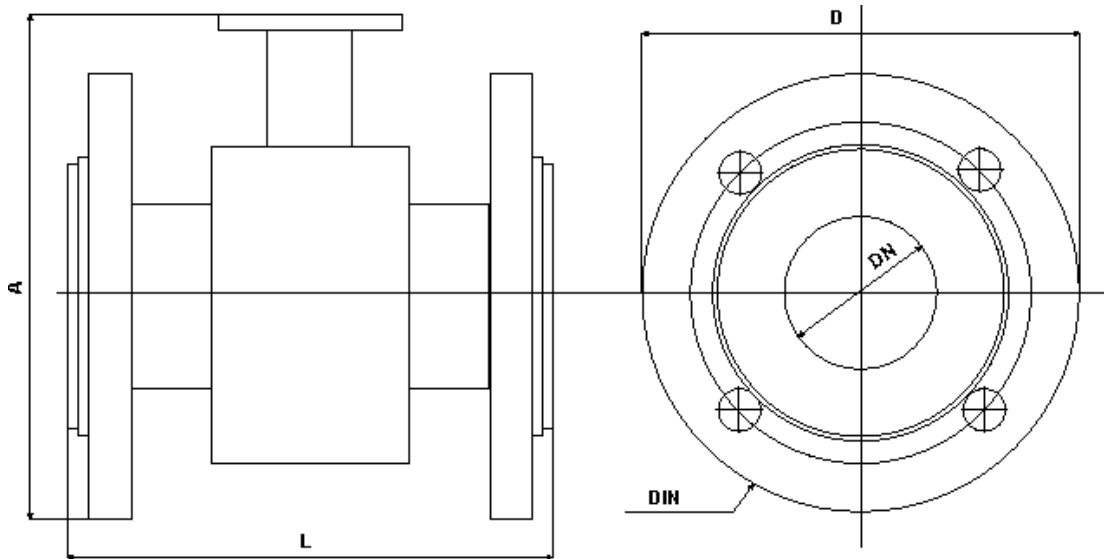

| DN (mm) | PN (bar) | D (mm) | A (mm) | L (mm) | Weight (kg) |
|---------|----------|--------|--------|--------|-------------|
| 10      | 16       | 90     | 140    | 150    | 3           |
| 15      | 16       | 95     | 145    | 200    | 3           |
| 20      | 16       | 105    | 150    | 200    | 3,5         |
| 25      | 16       | 115    | 155    | 200    | 3,5         |
| 32      | 16       | 140    | 165    | 200    | 5           |
| 40      | 16       | 150    | 175    | 200    | 6           |
| 50      | 16       | 165    | 185    | 200    | 7           |
| 65      | 16       | 185    | 200    | 200    | 9           |
| 80      | 16       | 200    | 215    | 200    | 11          |
| 100     | 16       | 220    | 235    | 200    | 12          |
| 125     | 16       | 250    | 265    | 300    | 22          |
| 150     | 16       | 285    | 295    | 300    | 24          |
| 200     | 16       | 340    | 355    | 400    | 35          |
| 250     | 10       | 395    | 435    | 400    | 42          |
| 300     | 10       | 445    | 485    | 500    | 57          |
| 350     | 10       | 505    | 535    | 500    | 72          |
| 400     | 10       | 565    | 580    | 500    | 95          |
| 500     | 10       | 670    | 695    | 500    | 120         |
| 600     | 10       | 780    | 800    | 600    | 160         |
| 700     | 10       | 895    | 900    | 700    | 230         |
| 800     | 10       | 1015   | 1010   | 800    | 330         |

**Table 1: Mag910 dimensions and weights – DIN flanges**

## **8.2 Used materials**

Electromagnetic flowmeter is made from materials, which meet international standards and conventions.

|                    |   |   |
|--------------------|---|---|
| <b>Liner:</b>      | Hard rubber<br>Teflon - PTFE                                | as standard   |
| <b>Electrodes</b>  | CrNi (stainless) steel 1.4571<br>Hastelloy C276<br>Tantalum | as standard   |
| <b>Sensor tube</b> | Stainless steel 1.4201,                                     | dimensions according to DIN 17457   |
| <b>Flange</b>      | Steel 1.0402 or higher,                                     | dimensions according to EN1092, DIN2501(=BS 4504), ANSI B16.5, Sanitary (DIN11851 or Tri Clamp), flangeless wafer style |

### 8.3 Flowrate versus diameter

The choice of flowrate for an electromagnetic flowmeter depends on the diameter of the sensor. The higher pipe diameter, the higher flowrate can be measured. A determining parameter for flowrates is maximum velocity of the liquid. Maximum velocity is the speed, where the flow of liquid inside pipe is still laminar. In Mag910 it is limited to 10m/s (with 125% overload). Speed over 10 m/s is usually too high for industrial applications. Such diameter of pipe is usually selected, where expected flowrate is between  $Q_{5\%}$  and  $Q_{50\%}$ .

In the table below applicable flowrates for various diameters is displayed in units l/s and m<sup>3</sup>/hr.

| DN   | Flowrates [ l/s ] |           |       |            |             |           | Flowrates [ m <sup>3</sup> /h ] |           |       |            |             |           |
|------|-------------------|-----------|-------|------------|-------------|-----------|---------------------------------|-----------|-------|------------|-------------|-----------|
|      | $Q_{1\%}$         | $Q_{5\%}$ | $Q_N$ | $Q_{50\%}$ | $Q_{100\%}$ | $Q_{MAX}$ | $Q_{1\%}$                       | $Q_{5\%}$ | $Q_N$ | $Q_{50\%}$ | $Q_{100\%}$ | $Q_{MAX}$ |
| 10   | 0,01              | 0,04      | 0,20  | 0,39       | 0,79        | 0,98      | 0,03                            | 0,14      | 0,80  | 1,41       | 2,83        | 3,53      |
| 15   | 0,02              | 0,09      | 0,50  | 0,88       | 1,77        | 2,21      | 0,06                            | 0,32      | 2,00  | 3,18       | 6,36        | 7,95      |
| 20   | 0,03              | 0,16      | 0,90  | 1,57       | 3,14        | 3,93      | 0,11                            | 0,57      | 3,20  | 5,65       | 11,31       | 14,14     |
| 25   | 0,05              | 0,25      | 1,40  | 2,45       | 4,91        | 6,14      | 0,18                            | 0,88      | 5,00  | 8,84       | 17,67       | 22,09     |
| 32   | 0,08              | 0,40      | 2,20  | 4,02       | 8,04        | 10,05     | 0,3                             | 1,5       | 8,00  | 14,5       | 29,0        | 36,2      |
| 40   | 0,1               | 0,6       | 4,0   | 6,3        | 12,6        | 15,7      | 0,5                             | 2,3       | 13,0  | 22,6       | 45,2        | 56,6      |
| 50   | 0,2               | 1,0       | 6,0   | 9,8        | 19,6        | 24,5      | 0,7                             | 3,5       | 20,0  | 35,3       | 70,7        | 88,4      |
| 65   | 0,3               | 1,7       | 9,0   | 16,6       | 33,2        | 41,5      | 1,2                             | 6,0       | 35,0  | 59,7       | 119,5       | 149,3     |
| 80   | 0,5               | 2,5       | 14,0  | 25,1       | 50,3        | 62,8      | 1,8                             | 9,0       | 50,0  | 90,5       | 181,0       | 226,2     |
| 100  | 0,8               | 3,9       | 20,0  | 39,3       | 78,5        | 98,2      | 3                               | 14        | 80    | 141        | 283         | 353       |
| 125  | 1                 | 6         | 30,0  | 61         | 123         | 153       | 4                               | 22        | 150   | 221        | 442         | 552       |
| 150  | 2                 | 9         | 50,0  | 88         | 177         | 221       | 6                               | 32        | 200   | 318        | 636         | 795       |
| 200  | 3                 | 16        | 100   | 157        | 314         | 393       | 11                              | 57        | 300   | 565        | 1131        | 1414      |
| 250  | 5                 | 25        | 150   | 245        | 491         | 614       | 18                              | 88        | 500   | 884        | 1767        | 2209      |
| 300  | 7                 | 35        | 200   | 353        | 707         | 884       | 25                              | 127       | 800   | 1272       | 2545        | 3181      |
| 350  | 10                | 48        | 300   | 481        | 962         | 1203      | 35                              | 173       | 1000  | 1732       | 3464        | 4330      |
| 400  | 13                | 63        | 400   | 628        | 1257        | 1571      | 45                              | 226       | 1300  | 2262       | 4524        | 5655      |
| 500  | 20                | 98        | 600   | 982        | 1963        | 2454      | 71                              | 353       | 2000  | 3534       | 7069        | 8836      |
| 600  | 28                | 141       | 800   | 1414       | 2827        | 3534      | 102                             | 509       | 3000  | 5089       | 10179       | 12723     |
| 700  | 38                | 192       | 1000  | 1924       | 3848        | 4811      | 139                             | 693       | 4000  | 6927       | 13854       | 17318     |
| 800  | 50                | 251       | 1200  | 2513       | 5027        | 6283      | 181                             | 905       | 5000  | 9048       | 18096       | 22620     |
| 900  | 64                | 318       | 1500  | 3181       | 6362        | 7952      | 229                             | 1145      | 6000  | 11451      | 22902       | 28630     |
| 1000 | 79                | 393       | 2000  | 3927       | 7854        | 9817      | 283                             | 1414      | 8000  | 14137      | 28274       | 35340     |

$Q_{1\%}$  - minimum applicable flowrate (minimum flowrate with guaranteed accuracy)

$Q_{5\%}$  - recommended minimum flowrate (minimum flowrate with best accuracy)

$Q_N$  - recommended nominal flowrate (expected working flowrate)

$Q_{50\%}$  - recommended maximum flowrate (maximum flowrate for industrial use)

$Q_{100\%}$  - maximum applicable flowrate (maximum flowrate with guaranteed accuracy)

$Q_{MAX}$  - maximum applicable overload ( $Q_{125\%}$ ) (flowmeter is still measuring)

**Table 2: Mag910 (Mag910E) flowrates**

A sensor diameter should be chosen to keep real flowrate between  $Q_{5\%}$  and  $Q_{50\%}$ , because in this range the flowmeter has the best accuracy.

## 9 Type plate

### Compact version

The type plate is located on the sensor. The following information is on the plate:

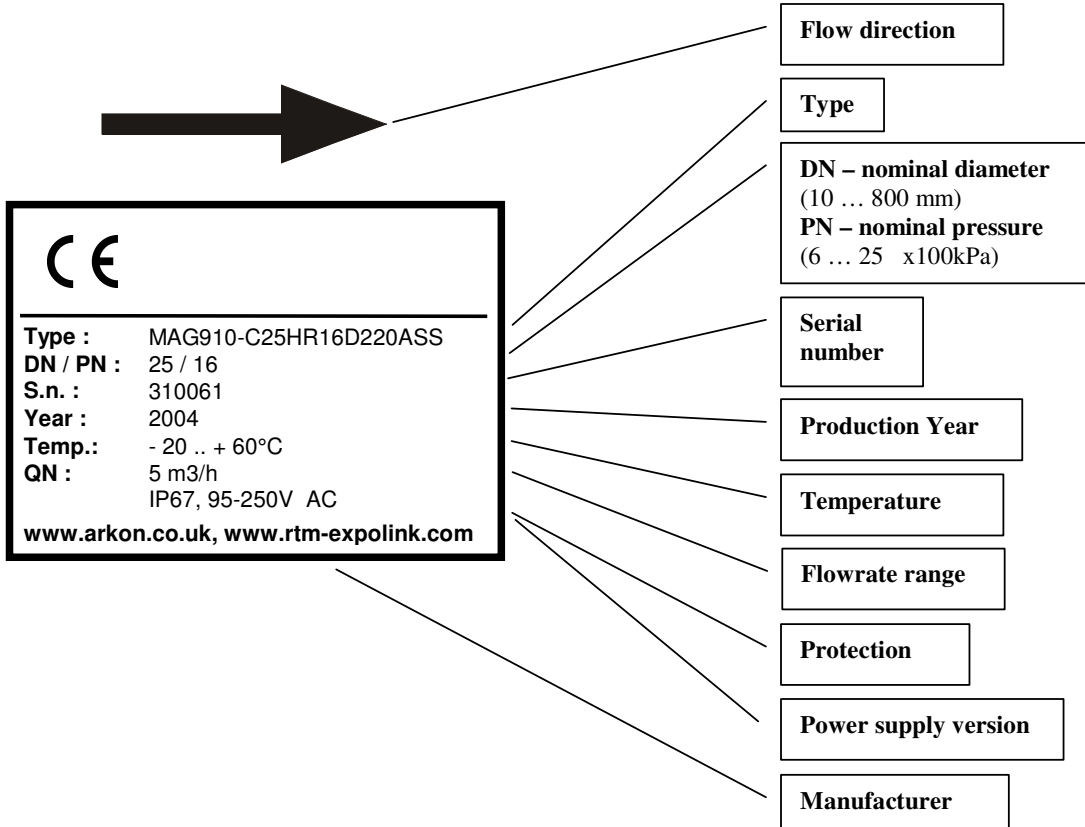

**Remote version**

Type plate on the **flanged sensor**:

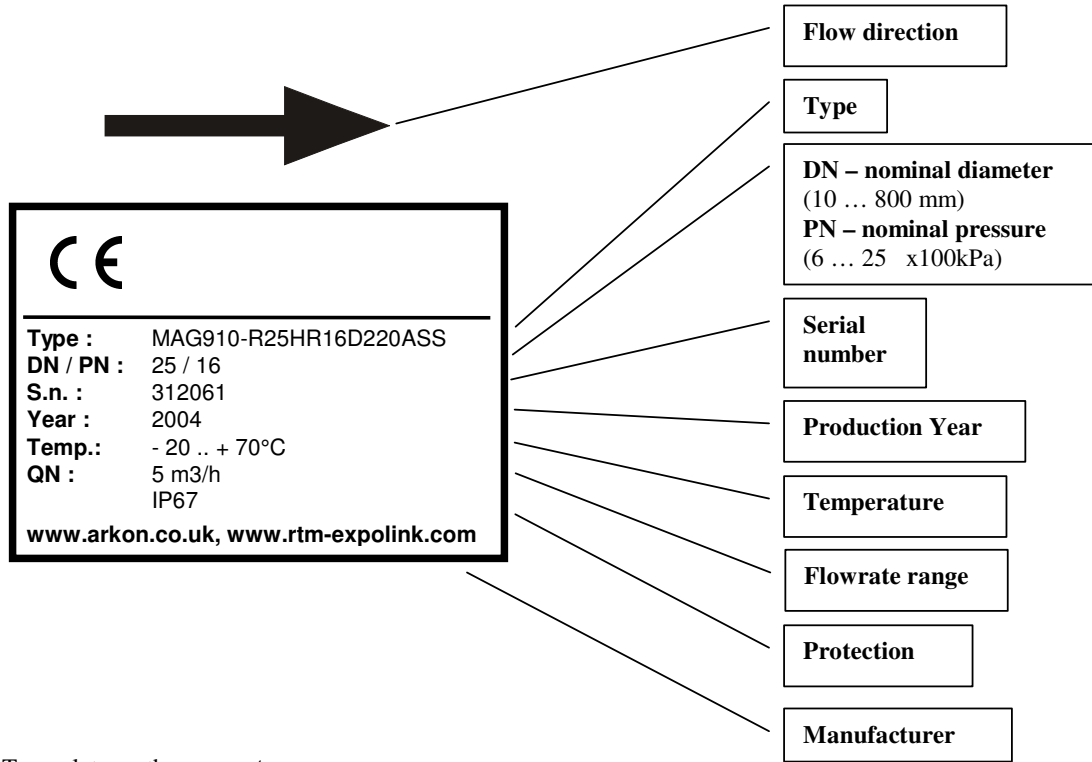

Type plate on the **converter**:

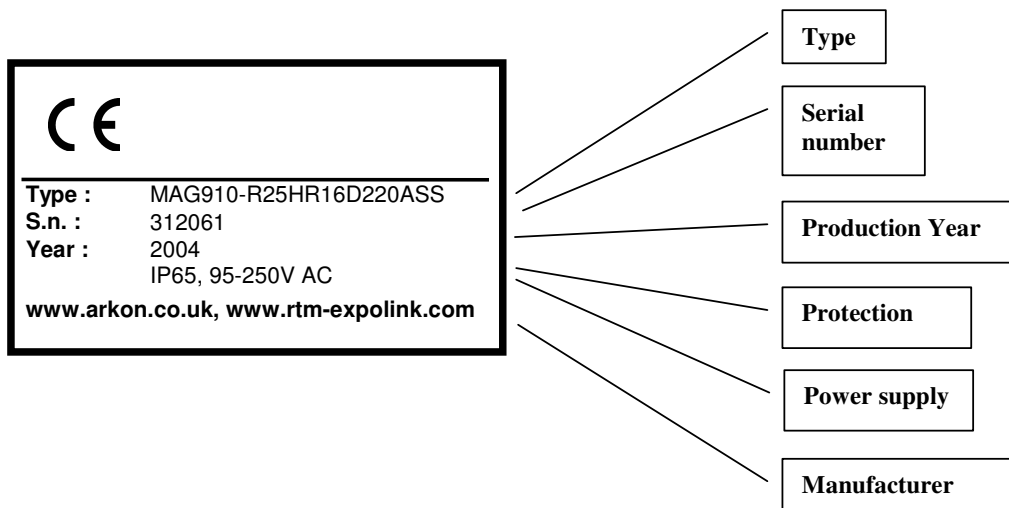



## 10 Technical data

|                                 |  |
|---------------------------------|--|
| Nominal size                    | DN10 to DN800  |
| Nominal pressure                | PN10 to PN40 (depending on nominal size)   |
| Flow range                      | 0.1 to 10 m/s (0.01 to 5000 l/s) / (0.03 to 18000 m <sup>3</sup> /h)   |
| Accuracy                        | <ul style="list-style-type: none"> <li>• 0.5 % (0.5 to 10 m/s) of reading value</li> <li>• 1 % (0.1 to 0.5 m/s) of reading value</li> </ul>  |
| Maximum media temperature       | 70°C (158°F) for rubber liner<br>130°C (266°F) for PTFE liner in remote version  |
| Minimum electrical conductivity | ≥ 5 μS / cm  |
| Ambient temperature             | -20 to 60 °C (-4 to 140°F)   |
| Power supply                    | <ul style="list-style-type: none"> <li>• 115/230V (+10%,-15%), 50/60Hz, auto selectable (Mag910-Vxx0x)</li> <li>• 115/230V (+10%,-15%), 50/60Hz, manual selectable (Mag910E-Vxx0x)</li> <li>• 12V DC (+20%, -10%), 12V 50/60Hz (+10%, -10%) (Mag910-Vxx1x), (Mag910E-Vxx1x)</li> <li>• 24V DC (+20%, -10%), 24V 50/60Hz (+10%, -10%) (Mag910-Vxx2x), (Mag910E-Vxx2x)</li> <li>• 48V DC (+20%, -10%), 48V 50/60Hz (+10%, -10%) (Mag910-Vxx3x), (Mag910E-Vxx3x)</li> </ul> |
| Power consumption               | 10 VA (Mag910), 9 VA (Mag910E)   |
| Liner                           | <ul style="list-style-type: none"> <li>• hard rubber</li> <li>• soft rubber</li> <li>• PTFE</li> </ul>   |
| Electrodes                      | <ul style="list-style-type: none"> <li>• CrNi (stainless) steel 1.4571</li> <li>• Hastelloy C276</li> <li>• Tantalum</li> </ul>  |
| Measuring tube                  | Stainless steel 1.4201, dimensions according to DIN 17457  |
| Flange                          | Steel 1.0402 or higher<br>Dimensions according to EN1092, DIN2501 (BS 4504), ANSI B16.5, Sanitary (DIN11851 or Tri Clamp), flangeless wafer style  |
| Protection category             | <ul style="list-style-type: none"> <li>• Compact version: IP67</li> <li>• Remote version: sensor IP68, converter IP65- optionally IP67</li> </ul>  |
| Outputs                         | <ul style="list-style-type: none"> <li>• Frequency 0 to 12 kHz with programmable flowrate and function</li> <li>• Pulse 0 to 50 Hz with programmable volume, function and pulse width</li> <li>• Relay contacts 100V/0.5A with programmable function (Mag910 only)</li> <li>• Current loop 4 to 20 mA with programmable flowrate and function</li> </ul>   |
| Input                           | PLC digital input with programmable function (Mag910 only)   |
| Communication                   | <ul style="list-style-type: none"> <li>• RS485 (Mag910 only)</li> <li>• RS232</li> </ul>   |
| Displayed values                | <ul style="list-style-type: none"> <li>• Flowrate (m<sup>3</sup>/h, l/s, US.Gal/min, user)</li> <li>• Volume (m<sup>3</sup>, l, US.Gal, user)</li> <li>• Positive, total, negative and auxiliary (clearable, daily) volume</li> </ul>  |
| Control                         | <ul style="list-style-type: none"> <li>• Keyboard (Mag910 only)</li> <li>• Magnetic pointer</li> <li>• RS232 and RS485</li> </ul>  |

## 11 Ordering information - options

### Mag 910 & sensor- C800HR16D220ASS

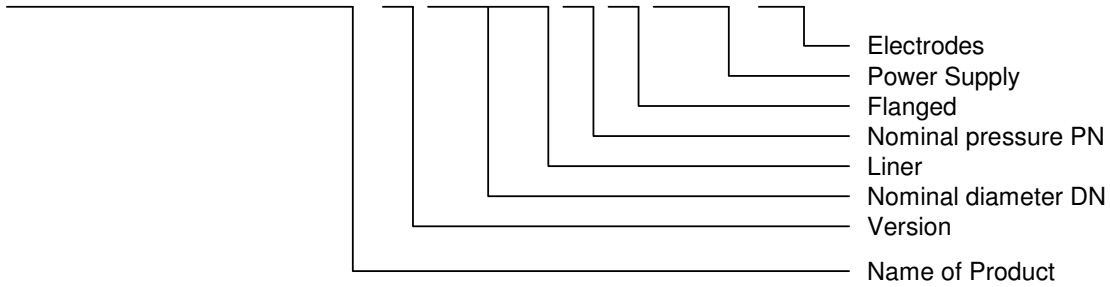

|                 |                            |                  |                             |
|-----------------|----------------------------|------------------|-----------------------------|
| <b>Version:</b> | <b>Nominal diameter DN</b> | <b>Liner:</b>    | <b>Nominal pressure PN:</b> |
| Compact - C     | 10 .. 800                  | Hard rubber – HR | 10, 16, 25, 40              |
| Remote - R      |                            | Soft rubber – SR |                             |
|                 |                            | PTFE - PT        |                             |

|                         |                      |                      |
|-------------------------|----------------------|----------------------|
| <b>Connection type:</b> | <b>Power Supply:</b> | <b>Electrodes:</b>   |
| Din - D                 | 12V DC - 12D         | Stainless Steel - SS |
| BS - B                  | 24V DC - 24D         | Titanium - TT        |
| ANSI - A                | 115-230V AC - 220A   | Platinum - PL        |
|                         |                      | Hastelloy - HA       |
|                         |                      | Tantalum - TA        |

### Mag 910 Transmitter Only - C220A

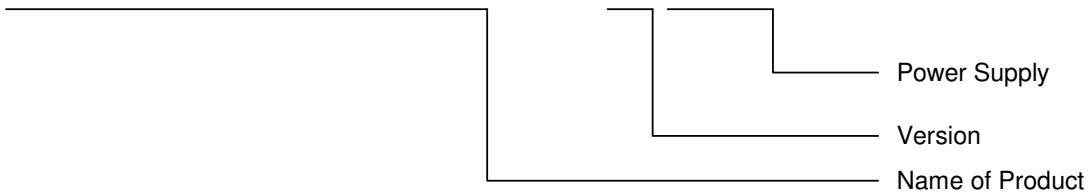

|                 |                      |
|-----------------|----------------------|
| <b>Version:</b> | <b>Power Supply:</b> |
| Compact - C     | 12V DC - 12D         |
| Remote - R      | 24V DC - 24D         |
|                 | 115-230V AC - 220A   |

#### 11.1 Example of order

1 pc. Mag 910 & sensor C800HR16D220ASS

## 12 Electronic unit exchange

Please contact your supplier.

## 13 Terminology

Special symbols and terms.

### Flowrates:

- Q<sub>1%</sub>** - minimum applicable flowrate (the least flowrate which has guaranteed measuring accuracy – depends on diameter – see table 2 Mag910 flowrates).
- Q<sub>5%</sub>** - recommended minimum flowrate (least flowrate which has the best measuring accuracy – depends on diameter – see table 2 Mag910 flowrates).
- Q<sub>N</sub>** - recommended nominal flowrate (nominal flowrate in which is flowmeter usually calibrated – depends on diameter – see table 2 Mag910 flowrates). You can predetermine this nominal flowrate in your order.
- Q<sub>50%</sub>** - recommended maximum flowrate (maximum flowrate which is usually used in industrial applications – depends on diameter – see table 2 Mag910 flowrates).
- Q<sub>100%</sub>** - maximum applicable flowrate (flowrate limit which has guaranteed measuring accuracy – depends on diameter – see table 2 Mag910 flowrates).
- Q<sub>MAX</sub>** - maximum applicable overload (**Q<sub>125%</sub>**) (maximum flowrate which can be still measured – depends on diameter – see table 2 Mag910 flowrates).

### Abbreviations:

- QI** - current output constant. It represents flowrate for current 20 mA.
- QF** - frequency output constant. It represents flowrate for frequency 1000 Hz.
- QP** - impulse output constant. It represents volume for 1 impulse.
- QD** - constant for dosing. It represents volume for 1 dose.
- PF1** - flowrate limit constant. It represents low limit flowrate. Crossing this limit activates the appropriate digital output.
- PF2** - flowrate limit constant. It represents high limit flowrate. Crossing this limit activates the appropriate digital output.
- H** - flowrate limit constant. It represents hysteresis by evaluating limits PF1 and PF2.

**Auxiliary volume counter** – second Total Volume counter. Can be cleared by pushing “RIGHT” key. It is usually used for measuring volume during day, month etc.

**RS232** – serial bus. It enables remote control of instruments by a computer. Only one instrument can be connected to one RS232 bus. Cable length between PC and instrument is limited to app. 10 metres.

**RS485** – serial bus. It enables remote control of instruments by a computer. To the RS485 can be connected more instruments (max. 16). Total cable length is limited to app. 800 metres.

## Appendix A Measuring principle

The flowmeter is designed for electrically conductive fluids. Measurement is based on Faraday's law of induction, according to which a voltage is induced in an electrically conductive body, which passes through a magnetic field. The following expression is applicable to the voltage:

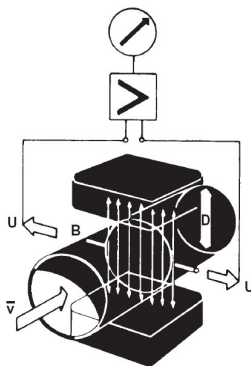

$$U = K \times B \times v \times D$$

where:

- U = induced voltage
- K = an instrument constant
- B = magnetic field strength
- v = mean velocity
- D = pipe diameter

Thus the induced voltage is proportional to the mean flow velocity, when the field strength is constant.

Inside the electromagnetic flowmeter, the fluid passes through a magnetic field applied perpendicular to the direction of flow. An electric voltage is induced by the movement of the fluid (which must have a minimum electrical conductivity). This is proportional to the mean flow velocity and thus to the volume of flow. The induced voltage signal is picked up by two electrodes, which are in conductive contact with the fluid and transmitted to a signal converter for a standardized output signal. This method of measurement offers the following advantages:

- No pressure loss through pipe constriction or protruding parts.
- Since the magnetic field passes through the entire flow area, the signal represents a mean value over the pipe cross-section; therefore, only relatively short straight inlet pipes x DN from the electrode axis are required upstream of the primary head.
- Only the tube liner and the electrodes are in contact with the fluid.
- Already the original signal produced is an electrical voltage, which is an exact linear function of the mean flow velocity.
- Measurement is independent of the flow profile and other properties of the fluid.

The magnetic field of the primary head is generated by a square wave current fed from the signal converter to the field coils. This field current alternates between positive and negative values. Alternate positive and negative flowrate-proportional signal voltages are generated at the same frequency by the effect of the magnetic field, which is proportional to the current. The positive and negative voltages at the primary head electrodes are subtracted from one another in the signal converter. Subtraction always takes place when the field current has reached its stationary value, so that constant interference voltages or external or fault voltages changing slowly in relation to the measuring cycle are suppressed. Power line interference voltages coupled in the primary head or in the connecting cables are similarly suppressed.

## Appendix B MAG910 Menu structure (Mag910 only)

There are three types of menu for parameters setting:

- **Setup menu**
- **Calibration menu**
- **Service menu**

Access to these menus is enabled after pushing the key “ENTER” from the *Main menu*. Each menu has its own password and you can enter this menu using an appropriate password only. Setup password you can change in setup menu, calibration password you can change in calibration menu. Service password is fixed and can be used for service purpose only (it is not described in this manual).

**Setup menu** has following submenus:

- 1 INPUT/OUTPUT
- 2 FLOWMETER
- 3 GENERAL

**Calibration menu** has following submenus:

- 1 INPUT/OUTPUT
- 2 FLOWMETER
- 3 GENERAL
- 4 CALIBRATION

**Service menu** has following submenus:

- 1 INPUT/OUTPUT
- 2 FLOWMETER
- 3 GENERAL
- 4 CALIBRATION
- 5 SERVICE (not described in this manual)

### Menu structure – password required

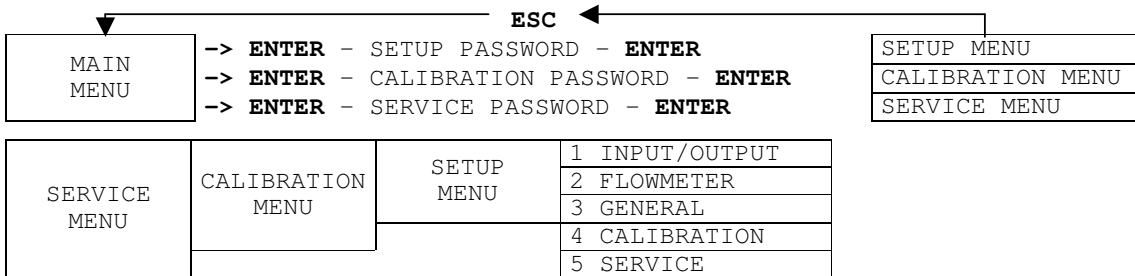



**FLOWMETER submenu structure**

|                           |                              |  |  |  |
|---------------------------|------------------------------|--|--|--|
| 2 FLOWMETER               | 2.A Datalogger               | Sampling rate in minutes, datalogger clear | (OFF, 5, 10, 15, 30, 45, 60, 120, 180, 240, CLR) |  |
|                           | 2.9 Date setting             | Real time clock date setting               |  |  |
|                           | 2.8 Time setting             | Real time clock time setting               |  |  |
|                           | 2.7 Time constant            | Time for flowrate moving average           | 1...20 sec                                       |  |
|                           | 2.6 Low-flow cutoff          | Flowrate for Low-flow cutoff               |  |  |
|                           | 2.5 Flowrate direction       | Positive                                   |  |  |
|                           |                              | Negative                                   |  |  |
|                           | 2.4 Volume resolution        | 0  |  |  |
|                           |                              | 0.0  |  |  |
|                           |                              | 0.00                                       |  |  |
|                           |                              | 0.000                                      |  |  |
|                           |                              | 0.0000                                     |  |  |
|                           | 2.3 Volume units             | m3 (cubic meter)                           |  |  |
|                           |                              | l (liter)                                  |  |  |
| US.G (US gallon)          |                              |  |  |  |
| user (user defined units) |                              |  |  |  |
| 2.2 Flowrate resolution   | 0                            |  |  |  |
|                           | 0.0                          |  |  |  |
|                           | 0.00                         |  |  |  |
|                           | 0.000                        |  |  |  |
|                           | 0.0000                       |  |  |  |
| 2.1 Flowrate units        | l/s (liters per second)      |  |  |  |
|                           | m3/h (cubic meters per hour) |  |  |  |
|                           | G/m (US gallons per minute)  |  |  |  |
|                           | User (user defined units)    |  |  |  |

Key ENTER →      ← Key ESC

**GENERAL submenu structure**

|              |                       |  |
|--------------|-----------------------|--|
| 3 GENERAL    | 3.7 Password menu     | Password changing                                      |
|              | 3.6 Current loop test | On   |
|              |                       | Off  |
|              | 3.5 Self test         | On   |
|              |                       | Off  |
|              | 3.4 Power supply      | Information only (Power supply voltage and frequency). |
|              | 3.3 Serial number     | Flowmeter serial number.                               |
|              | 3.2 Nominal range     | Flowrate for Q <sub>N</sub> .                          |
| 3.1 Diameter | Diameter in mm.       |  |

Key ENTER →      ← Key ESC

**CALIBRATION submenu structure**

|          |               |                              |  |   |
|----------|---------------|------------------------------|--|---|
| Key UP ↑ | 4 CALIBRATION | 4.6<br>Calibration Password  | Calibration password changing.                   |   |
|          |               | 4.5<br>Cal. Point 4          | Nominal value of calibration point 4 (flowrate). | Calibration constant for calibration point 4. |
|          |               | 4.4<br>Cal. Point 3          | Nominal value of calibration point 3 (flowrate). | Calibration constant for calibration point 3. |
|          |               | 4.3<br>Cal. Point 2          | Nominal value of calibration point 2 (flowrate). | Calibration constant for calibration point 2. |
|          |               | 4.2<br>Cal. Point 1          | Nominal value of calibration point 1 (flowrate). | Calibration constant for calibration point 1. |
|          |               | 4.1<br>Number of Cal. Points | Number of Calibration points.                    | 2 ... 4                                       |
|          |               | Key ENTER →                  |  |   |
|          |               | ← Key ESC                    |  |   |