

# WindObserver™ 70

## Ultrasonic Anemometer



### Key Features

- FAA & CAA accepted\* for airport applications
- Heating power 7A @24VAC or DC (1W/cm<sup>2</sup>)
- 0-70m/s wind speed range
- 0-359° wind direction range (no dead band)
- Calibration traceable to NAMAS standards
- IP66 rated stainless steel housing
- Connector or cable exit options
- Optional customer base mounts

The WindObserver 70 is a solid state, heated ultrasonic anemometer designed for use within the aviation industry and for more extreme weather conditions. The sensor has been accepted for service by both the FAA Federal Aviation Administration (USA) and the CAA Civil Aviation Authority (UK) for the observation and reporting of surface wind. This WindObserver meets the requirements of Annex 3 to the Convention on International Civil Aviation Organization (ICAO) when supplied as part of a suitable AWOS\*.

With 150 Watts of electrical heating in the anemometer head producing 1 Watt/cm<sup>2</sup> and tested in accordance with MILSTD810F, the unit is particularly suited to operate as part of Aviation Automatic Weather Observing Systems, which are often exposed to extreme weather conditions. Manufactured from stainless steel with no moving parts the sensor requires no on-site calibration and minimal maintenance.

\*Accepted by the FAA & CAA for the observation and reporting of surface wind as part of a suitable AWOS (Automatic Weather Observing System)



### Wind Speed

Range	0 - 70 m/s (0-156mph)
Starting threshold	0.01 m/s
Accuracy	±2% @12 m/s
Resolution	0.01 m/s
Offset	±0.01 m/s

### Direction

Range	0 - 359°
Dead band direction	None
Accuracy	±2° @12 m/s
Resolution	1°

### Measurement

Ultrasonic output rate	1 - 4Hz
Parameters	UV, Polar, NMEA
Units	m/s, knots, mph, kph, ft/min
Averaging	Flexible 1-3600 seconds

### Power Requirement

Anemometer only	9 - 30 VDC (60mA max, 50mA average)
Heating	Max 7A @24 VAC or DC

### Digital Output

Communication (Operat'n)	RS422/RS485 full duplex/half duplex
Baud Rates	1200, 2400, 4800, 9600, 19200, 38400
Formats	8 bit data; odd, even or no parity
Anemometer status	Supplied as part of standard message

### Mechanical

External construction	Stainless steel 316
Size	Refer to diagram overleaf
Weight	1.7kg (with 2m cable) 1.3kg (with connector)

### Environmental

Protection class	IP66 (NEMA4X)
Operating temperature	-55°C to +70°C (with base connector)
Precipitation	300mm/hr
EMC	EN 61326-1: 2006, EN 55011: 2007
Icing	MILSTD810F Method 521.2 Procedure I

### Approvals

Standards	Traceable to NAMAS standards
Site Calibration	None required. Integrity check unit (Zero wind) supplied as optional extra

# WindObserver™ 70

## Ultrasonic Anemometer

### Typical Applications

- Aviation Weather Observing Systems
- Aircraft Landing Systems
- Remote Meteorological Systems
- Helicopter Landing Pads
- Transport Safety

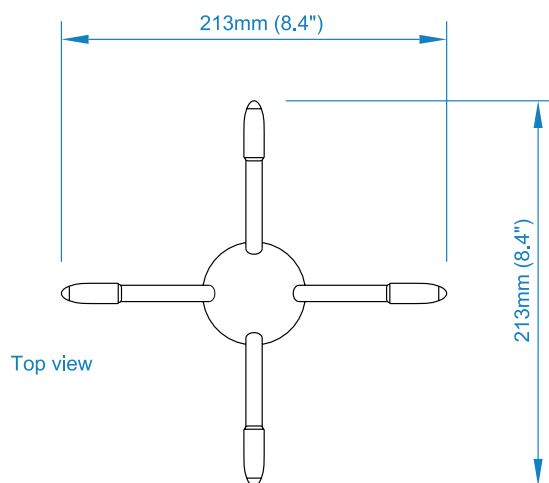
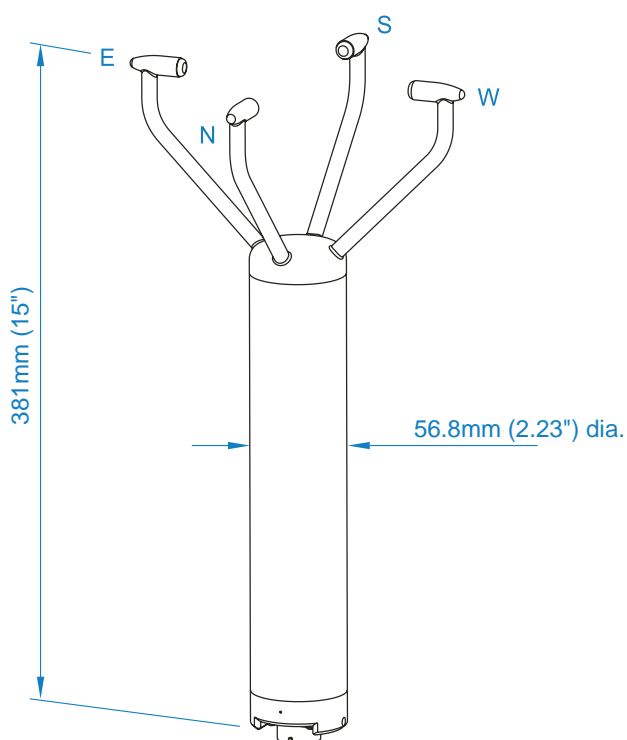

Note: Optional base mounts and cable exit options are available.

Specifications may be subject to change without prior notice.



For pricing or any further information, please contact Omni Instruments Ltd.

## WindObserver Product Numbers Explained

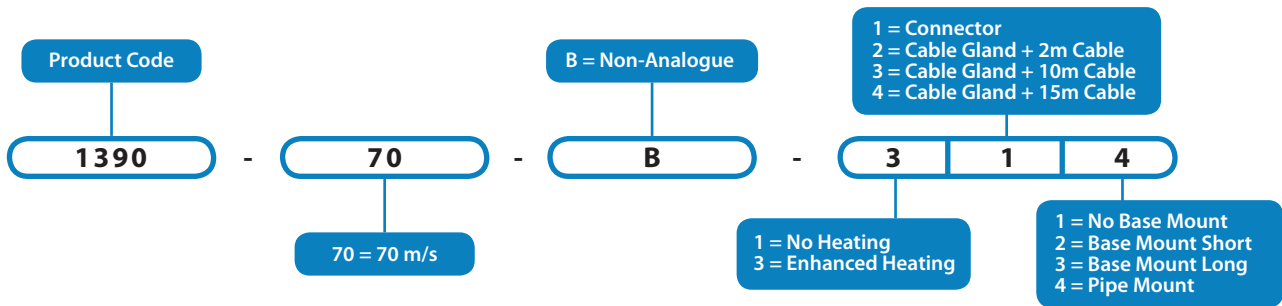

Product options may be model specific. Consult the Omni Instruments sales team for availability

## Connection Options

Drawings below shown without base mounts

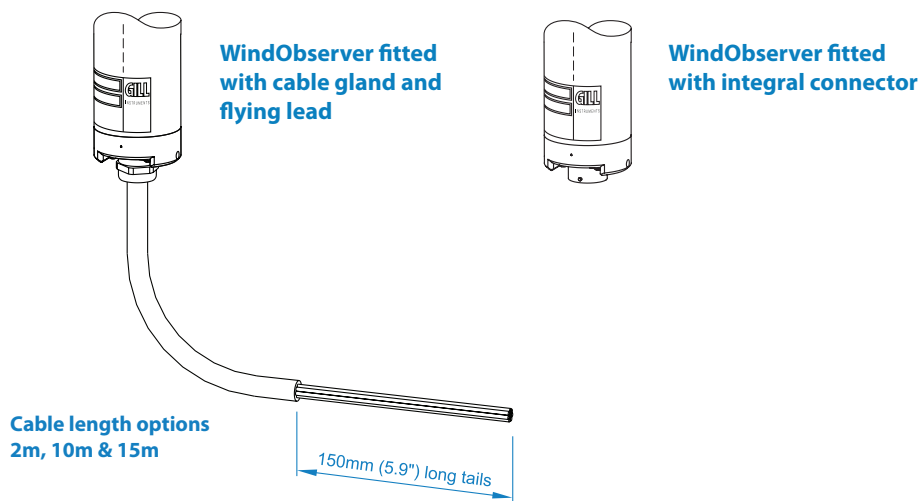

## Base & Pipe Mount Options

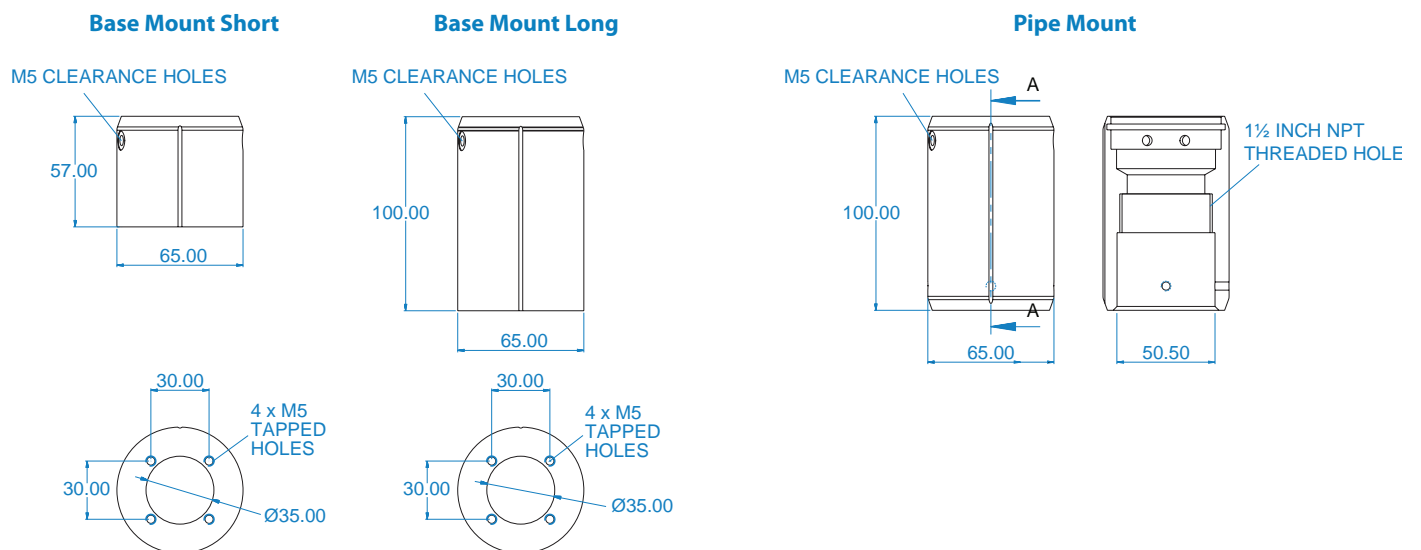

All options are supplied with appropriate fixing screws and washers.

For pricing or any further information, please contact Omni Instruments Ltd.