

## Key Features

- Precision 3-axis sonic anemometer
- 32Hz output rate
- 0-65m/s wind speed
- 0-359° wind direction
- U, V, W vector outputs
- Sonic temperature output
- Stainless steel construction
- Optional custom calibration

The 3D WindMaster Pro is a precision anemometer offering three-axis wind measurement data. This instrument will monitor wind speeds of 0-65m/s and provides sonic temperature, speed of sound and U, V & W vector outputs at 32Hz as standard. The unit also features improved vertical (W) resolution and speed of sound accuracy and less distortion due to wind loading. Each WindMaster Pro is calibrated with a Gill wind tunnel test to provide optimum performance. Optional analogue inputs and outputs plus a PRT are available with 14 bit resolution.

This anemometer is of stainless steel external construction and is particularly suitable for precision wind measurement applications requiring 3-axis data involving high wind speeds.



### Wind Speed

Range	0 - 65 m/s
Resolution	0.01 m/s
Accuracy*	<1.5% RMS @12 m/s
Accuracy*	<1% RMS @12 m/s (Custom)

### Direction

Range	0 - 359°
Resolution	0.1°
Accuracy	2° @12 m/s
Accuracy	0.5° @12 m/s (Custom)

### Sonic Temperature

Range	-40°C to +70°C
Resolution	0.01°C

### Speed of Sound

Range	300-370 m/s
Resolution	0.01 m/s
Accuracy	< ±0.5% @ 20°C

### Measurement

Internal sample rate	32 Hz
Output parameters	1, 2, 4, 8, 10, 16, 20 & 32 Hz
Units of measure	m/s, mph, kph, knots, ft/min
Formats	UVW, Polar or NMEA
Averaging	Flexible 0-3600 s

\*Accuracy spec applies for wind speed, and for wind incidence up to ±30° from the horizontal

### Digital Output

Communication	RS232, 422, 485
Baud rates	2400 - 115200
Format	ASCII

### Analogue Outputs - Optional

Resolution 14 bits	4 channels available
Selectable range	User selectable full scale wind speed
Output type	0-20mA, 4-20mA, 0-5 V, ±2.5 V, ±5 V

### Analogue Inputs - Optional

Resolution 14 bits	Up to 4 single ended or 2 differential plus PRT 100 input
Input type	±5 V

### Power Requirement

Anemometer	9-30 VDC (30mA @12 VDC)
------------	-------------------------

### Mechanical

Weight	1.7 kg
Size	750mm x 240mm

### Environmental

Protection class	IP65
Operating temp	-40°C to +70°C
Humidity	< 5% to 100% RH
Precipitation	300mm/hr
EMC	BS EN 61000 - 6 - 3 (Emissions) BS EN 61000 - 6 - 2 (Immunity)

## Typical Applications

- Meteorological Systems
- Flux Systems
- Structural Safety
- Wind Profiling
- Marine Research
- Wind Turbine Site Survey

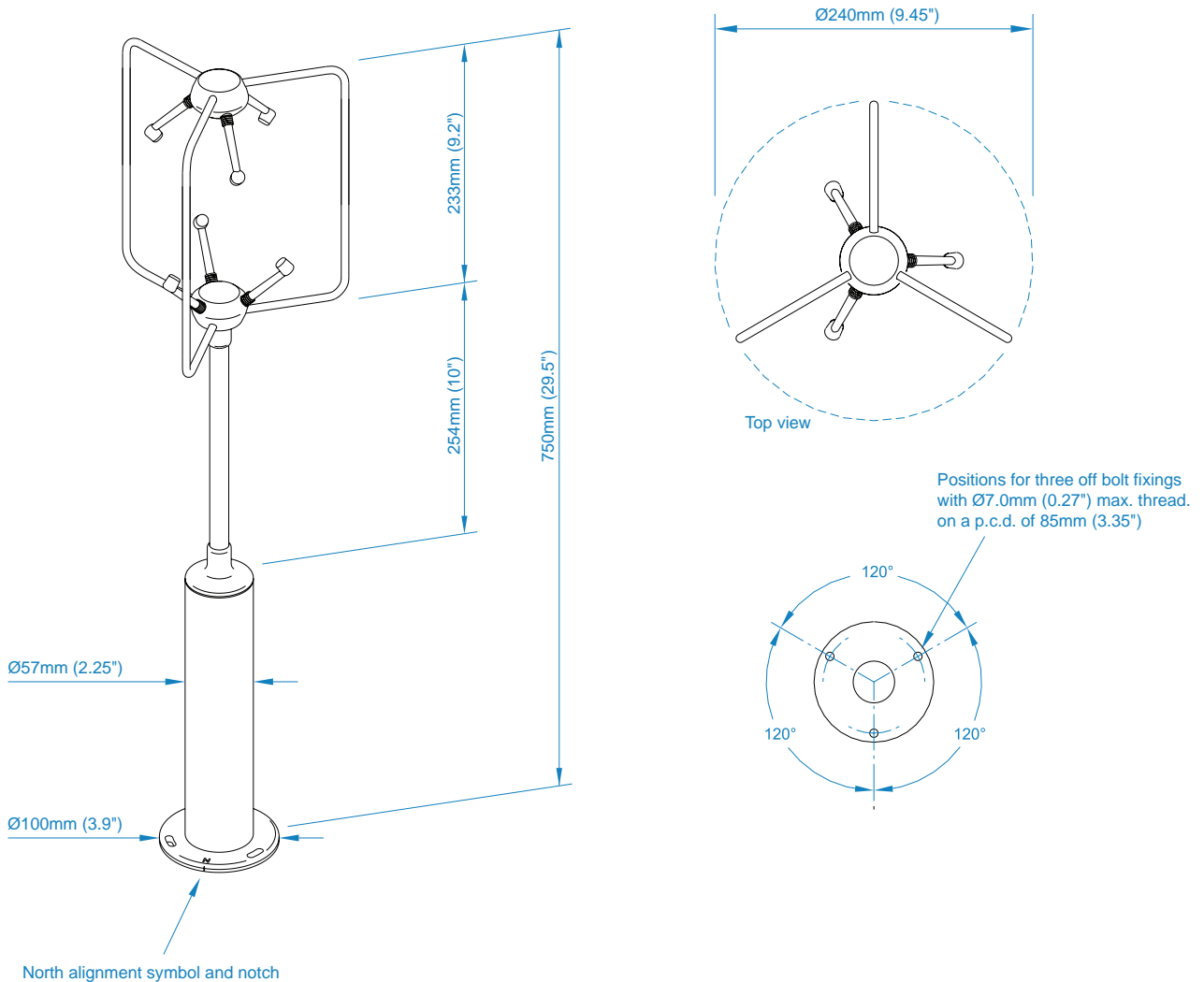

This product is in continuous development and therefore specifications may be subject to change without prior notice.



For pricing information contact Omni Instruments by phone on +44 845 9000 601 or via email at [info@omni.uk.com](mailto:info@omni.uk.com)