

Air Differential Pressure Transmitter



Features

- IP65 Housing
- Over pressure safety margin 10psi
- 2 accuracy levels to suit application

Specification

Accuracy:	Standard	High
Overall	± 1.00% fsd	± 0.40% fsd
Linearity	± 0.98% fsd	± 0.33% fsd
Hysteresis	± 0.20% fsd	± 0.20% fsd
Repeatability	± 0.10% fsd	± 0.10% fsd
Total	± 1.28% fsd	± 0.63% fsd
Thermal effect	± 0.06% per °C	
Overpressure	10 psi	
Rupture	10 psi	
Pressure connections	Push fit for 5mm ID tube	
Output:		
Current	4-20mA, load = 100 to 800W	
Voltage	0-10Vdc (o/p impedance < 100kΩ)	
Power supply:		
Current output	9 to 30Vdc	
Voltage output	12-30Vac or 13-42Vdc	
Speed of reaction:		
Without filter	20ms	
With filter	40ms	
Electrical Connections	Screw terminals for 1.5mm ² max.	
Diaphragm	Stainless steel 304	
Housing	Glass-filled Polycarbonate to UL94V-0	
Protection	IP65	
Operating Temp.	-18°C to +65°C	
Dimensions	158 x 80 x 60mm max.	
Country of origin	USA	

Product Codes

PA-267-25	0 to 25Pa Air differential pressure transmitter
PA-267-50	0 to 50Pa Air differential pressure transmitter
PA-267-100	0 to 100Pa Air differential pressure transmitter
PA-267-300	0 to 300Pa Air differential pressure transmitter
PA-267-500	0 to 500Pa Air differential pressure transmitter
PA-267-1000	0 to 1000Pa Air differential pressure transmitter
PA-267-1600	0 to 1600Pa Air differential pressure transmitter
PA-267-2500	0 to 2500Pa Air differential pressure transmitter
PA-267-3000	0 to 3000Pa Air differential pressure transmitter

For options add suffix to the partcode (at extra cost):

-AH	For 0.4% accuracy
-V	For voltage output
-B	For Bi-directional output
-LCD	For integral LCD option

A 'duct fixing kit' is supplied with the PA-267 consisting of 2m of 6mm ID plastic tubing, 2 x pitot tubes, 4 x fixing screws.

Technical Overview

The PA-267 is designed for overpressure, under pressure, and differential pressure measurements of air and other neutral gases. It is recommended that for applications where control is involved, the high accuracy version is used. The measurement cell uses an advanced design of capacitive element to ensure excellent linearity and zero stability. The differential pressure to be measured induces a movement of the stainless steel diaphragm which is converted to an electronic output signal by a capacitance measurement and a unique electronic circuit.

Velocity Measurement

The PA-267 can be used for accurate air velocity measurement in applications such as variable fan speed control in VAV applications.

NB The units are calibrated with the transducer in the vertical position. The zero adjustment may be used to correct any shift in output resulting in mounting the unit other than vertically.

Tubing

It is recommended for best results (shortest response times) 6mm I.D tubing lengths up to 30.5m
7mm I.D tubing lengths up to 91.5m
9.5mm I.D for tubing lengths up to 274m.

Bi-Directional

The PA-267 is also available with bi-directional pressure ranges, enabling measurement of both positive and negative pressures. The two output ranges are offered 0-10Vdc and 4-20mA.

Example, PA-267-50-B at -50Pa the output is 4mA, 0Pa the output is 12mA and at +50Pa the output is 20mA. Therefore the output is linear across the range.

Installation

1. Mount the unit on the duct or wall by drilling two holes at 142mm centres and fixing the unit with self-tapping pan head screws.
2. Push fit the pressure tubing onto the pressure ports on the unit. Ensure that the Hi and Lo ports have been correctly identified.

Installation (continued)

- 3 (a) 4-20mA output version:
Wire to the unit with 2 core screened cable. Do not connect the screen at the sensor end, but ensure it is earthed at the controller end. See **Fig. 1**
- 3 (b) 0-10Vdc output version:
Wire to the unit with 3 core screened cable. Do not connect the screen at the sensor end, but ensure it is earthed at the controller end. See **Fig. 2**

Connections

Fig.1

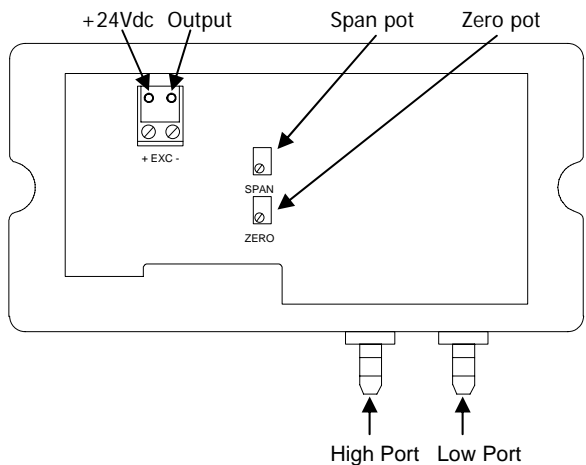
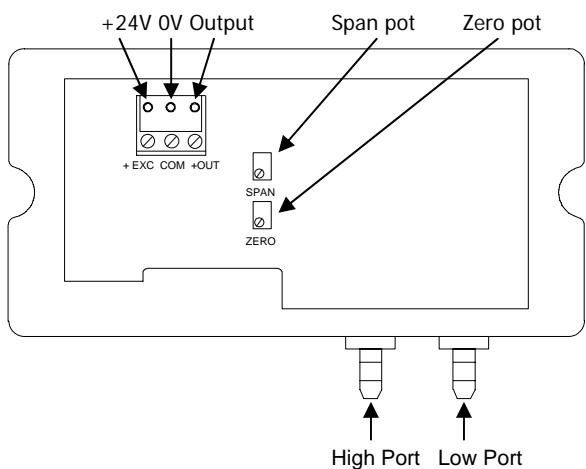

Fig.2



CAUTION

The PA-267 will be damaged if subjected to excessive pressure. Do not test the unit by blowing into the inlet ports.

Dimensions

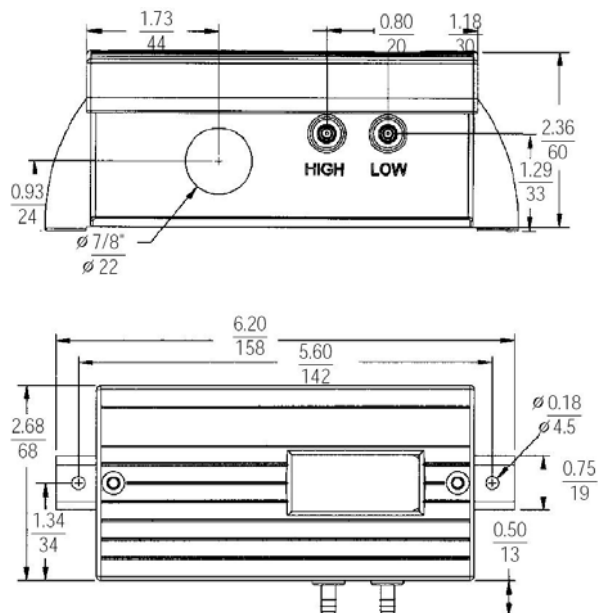

Trend Scaling

4-20mA:

Range	Exp	Trange	Brange	Upper	Lower
25Pa	3	25	-37.5	25	0
50Pa	3	50	-75	50	0
100Pa	3	100	-150	100	0
300Pa	3	300	-450	300	0
500Pa	4	500	-750	500	0
1000Pa	4	1000	-1500	1000	0
1600Pa	4	1600	-2400	1600	0
2500Pa	4	2500	-3750	2500	0
3000Pa	4	3000	-4500	3000	0

0-10Vdc:

Range	Exp	Trange	Brange	Upper	Lower
25Pa	3	25	-25	25	0
50Pa	3	50	-50	50	0
100Pa	3	100	-100	100	0
300Pa	3	300	-300	300	0
500Pa	4	500	-500	500	0
1000Pa	4	1000	-1000	1000	0
1600Pa	4	1600	-1600	1600	0
2500Pa	4	2500	-2500	2500	0
3000Pa	4	3000	-3000	3000	0