

Stainless Steel Miniature Compression **LOAD CELL**

CDFM3 Series



- Capacities 100N to 20kN
- Sealed to IP65
- Just 30mm in diameter and 12mm in height
- Integral Load Button
- Robust Construction
- **3 YEAR WARRANTY**

Options Available

Non-Standard sizes available on request

Other ranges available on request

Special mounting adaptors available on request

Shunt Calibration Facility

Different temperature compensation ranges available

DESCRIPTION

The CDFM3 range of low profile miniature load cells is designed for the measurement of compressive forces. The CDFM3 is equally suited for both Force Measurement and Weighing applications alike. It's compact size means that it can be fitted into small space envelopes and is often retro-fitted, while the M3 threads in it's base make fixing the load cell in position a simple task.

The small physical size has made it very attractive in many industrial process measurement applications for monitoring or control purposes. It is equally suited and performs well in a wide range different research and development applications.

The CDFM3, as with all other Omni Instruments Ltd sensors, can be supplied complete with monitoring/control electronics and calibrated as a system (please refer to the Instrumentation datasheets).

For pricing or any further information, please contact Omni Instruments Ltd.

SPECIFICATION

Wiring Schematic Diagram

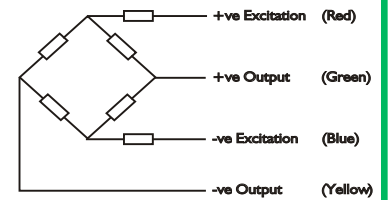

CHARACTERISTICS	CDFM3	UNITS
Rated Capacities:	100, 250, 500, 1000, 2000, 5000, 10k, 20k	N
Rated Output:	2 nominal (1.5 nominal on 100N)	mV/V
Non-Linearity:	<0.25	±% of Rated Output
Hysteresis:	<0.25	% of Rated Output
Zero Balance:	<1.0	±% of Rated Output
Temperature Range Operating:	-20 to +80	°C
Compensated:	0 to +70	°C
Temperature Effect On Output:	<0.005	±% of Applied Load/ °C
On Zero:	<0.030	±% of Rated Output/ °C
Safe Overload:	125	% of Rated Capacity
Ultimate Overload:	150	% of Rated Capacity
Excitation Recommended:	10	Volts AC or DC
Maximum:	15	Volts AC or DC
Input Impedance:	375	Ohms
Output Impedance:	350	Ohms
Insulation Impedance:	>500	Megaohms
Construction:	Stainless Steel	
Environmental Protection:	IP65	
Cable:	2 Metre 4 Core Screened	

All dimensions in mm

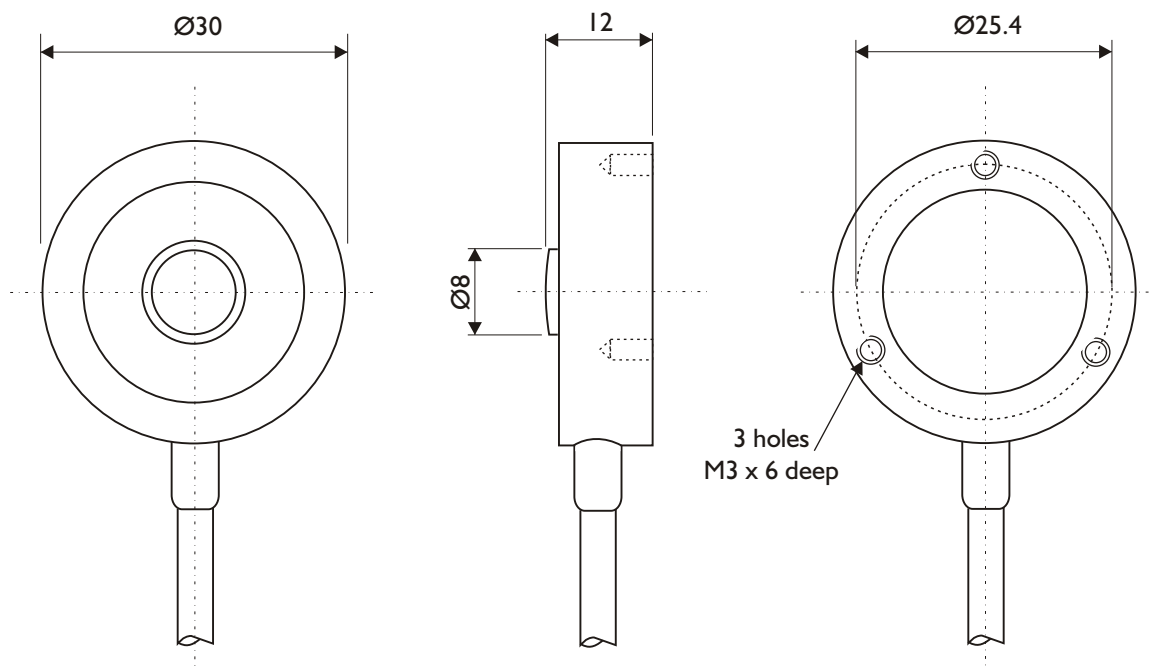

For a smaller version of the CDFM3 look at our CDF which is available in capacities from 0-500N up to 0-2kN

For pricing or any further information, please contact Omni Instruments Ltd.