

INSTALLATION

The transmitter is intended for DIN rail mounting. Its drawing is preseted in Figure 04.

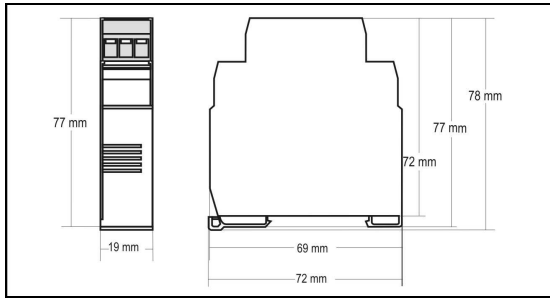

Figure 04 – Transmitter dimensions

ELECTRICAL CONNECTIONS

Figure 5 below shows the transmitter connections to the sensor and power supply. Terminals 1, 2 e 3 are used for sensor input. For 2-wire Pt100, terminals 2 and 3 shall be connected together.

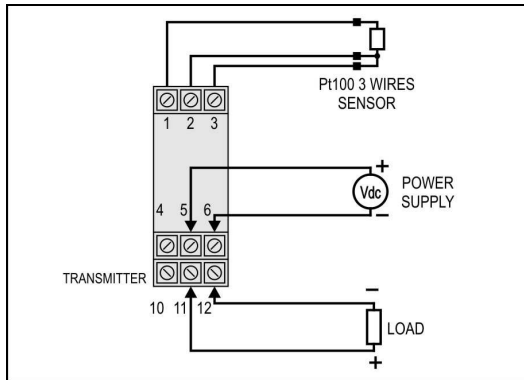

Figure 05 – Transmitter wiring – Pt100

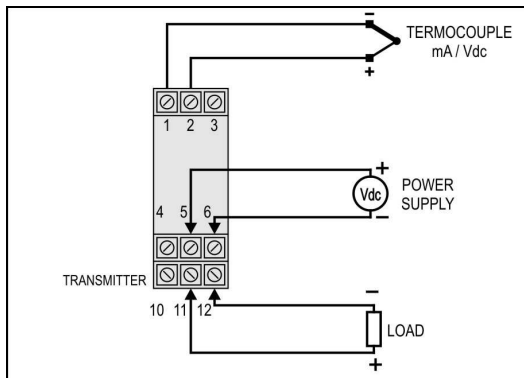

Figure 06 – Transmitter wiring (Thermocouple, mA, Vdc)

The **LOAD** represents voltage metering instrument (indicator, controller, register, etc.).

Electrical Connections – 0-10 Vdc input

For 0-10 Vdc input, the transmitter requires an internal hardware configuration change. Please open the instrument case and change the jumper shown in Figure 07.

- Position 1-2 : 0-10 Vdc input
- Position 2-3 : al other input types (factory setting).

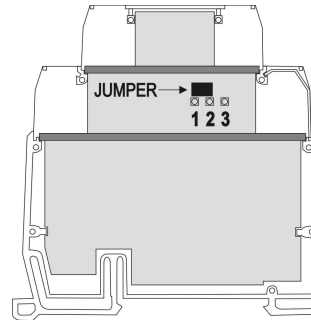

Figure 07 – Jumper position for 0-10 Vdc input

OPERATION

All input types and the 0-10Vdc output are factory calibrated.

However, a manual offset trim is implemented to provide fine adjustments to the signal in the field. This is accomplished by the front keys ZERO+ and ZERO-. Using a small tool, press and hold the desired key for at least 2 seconds to increase or decrease the output. The offset adjustment is capable of varying the output current by an amount equal to $\pm 5\%$ relative to the original calibration.

The offset correction can also be accomplished by the TxConfig software. See in Figure 3 the **Zero Correction** field for this purpose. The serial adaptor can be connected to the transmitter while it is operating in the process.

The input types are listed in Table 1, along with the maximum and minimum ranges accepted by each one. The TxConfig software will allow only configurations that are consistent with the data in this table.

Please note that the specified accuracy is referenced to the maximum span of each input type. For instance, for the Pt100 input, the 0.2% accuracy results in 1.7°C total accuracy $[(650 - (-200)) \times 0.2]$.

Note: when using a Pt100 simulator, make sure the transmitter Pt100 excitation current (0.18mA) is compatible with the simulator specification.

MICROPROCESSOR

BASED TEMPERATURE TRANSMITTER

TxIsoRail 0-10Vdc

INSTALLATION AND OPERATING MANUAL



Australia / Asia Pacific Office
Tel +61 (0)282 442 363
Fax +61 (0)294 751 278
info@omniinstruments.com.au
www.omniinstruments.com.au

UK / Europe Office
Tel: +44 (0)845 9000 601
Fax: +44 (0)845 9000 602
info@omniinstruments.co.uk
www.omniinstruments.co.uk

USA / Canada Office
Tel +1-866-849-3441
Fax +1-866-628-8055
info@omniinstruments.net
www.omniinstruments.net

SPECIFICATIONS

Sensor input: User defined. The supported sensors are listed in table 01, along with their maximum ranges.

Thermocouples: Types J, K, R, S, T, N, E and B, to IEC 60584 (ITS-90). Impedance >> 1 M Ω

Pt100: Excitation: 180 μ A, 2 or 3-wire connection (for 2-wire sensors, tie terminals 2 and 3 together).

α = 0.00385, according to IEC 60751(ITS-90).

Voltage: 0 to 50 mVdc, 0 to 10 Vdc; Impedance: > 1 M Ω

Current: 0 to 20 mA, 4 to 20 mA; Impedance: 15.0 Ω (+ 1,9 Vdc)

Sensor Type	Range	Minimum measurement span
Thermocouple K	-150 to 1370 °C	100 °C
Thermocouple J	-100 to 760 °C	100 °C
Thermocouple R	-50 to 1760 °C	400 °C
Thermocouple S	-50 to 1760 °C	400 °C
Thermocouple T	-160 to 400 °C	100 °C
Thermocouple N	-270 to 1300 °C	100 °C
Thermocouple E	-90 to 720 °C	100 °C
Thermocouple B	500 to 1820 °C	400 °C
Pt100	-200 to 600 °C	40 °C
Voltage	0 to 50 mV	5 mV
	0 to 10 V	1 V
Current	0 to 20 mA	2 mA
	4 to 20 mA	2 mA

Table 01 – Transmitter input sensors

Output: 0 to 10 Vdc, linear with respect to the measured temperature.

Resolution: 0,0006 V (14 bits)

Maximum Current (Load): 2 mA

Total Accuracy: 0,25 % of the maximum range for thermocouples, \pm 1°C; 0,15 % for Pt100, mA and voltage (for voltage output above 100mV).

Response Time: < 500 ms

Power Supply: 18 to 35 Vdc

Operating Temperature: -40 to 85 °C

Humidity: 0 to 90 % UR

Eletromagnetic Compatibility: EN 50081-2, EN 50082-2

Isolation between the sensor and the 4-20mA loop (1000V / 1min).

Internal protection against polarity inversion.

Cold junction compensation for thermocouples.

Housing: ABS plastic. **Dimensions:** Refer to Figure 04.

CONFIGURATION

If the transmitter is already configured as required by the application (sensor type, range, etc), it may be installed and used right away. However, if a distinct configuration is required, this can be done through the **TxConfig software** and the **TxConfig Interface**.

The TxConfig Interface and Software can be purchased separately one of its distributors. The latest release of this software can be downloaded from our web site. Do not save the TxConfig software into a file which contains accent marks. To install, run the **Tx_setup.exe** and follow the instructions. To install the configurator, run the **Tx_setup.exe** file.

Serial port configuration errors may occur when other devices are sharing the same port (ex.: Palm Hot Synch). Close all serial port applications prior to using the TxConfig software.

The TxConfig interface connects the transmitter to the PC, as shown in Figures 01 and 02. There are two types of interface: TxConfig-RS232 and TxConfig-USB.

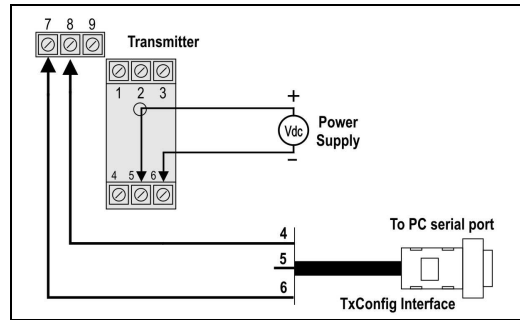

Figure 01 – TxConfig Interface connections model RS232

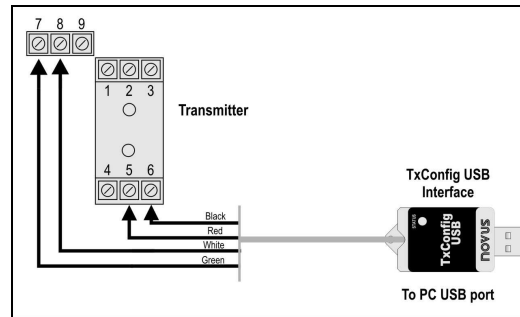

Figure 02 – TxConfig Interface USB connections

Once the connection is accomplished, the software shows the configuration options of the transmitter model attached. Access the *Help* for usage instructions.

The **TxConfig** screen is shown in Figure 3

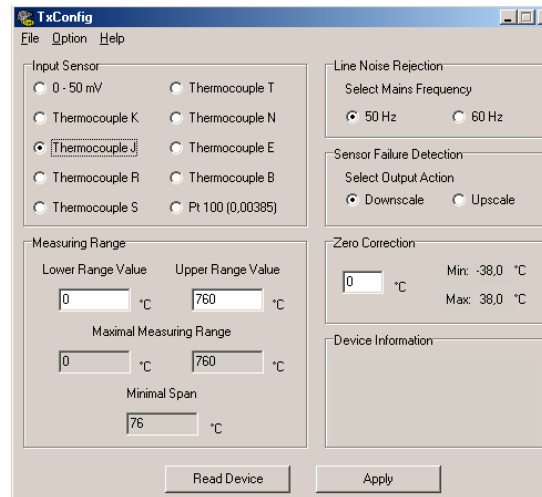

Figure 03 – TxConfig main screen

The fields in the screen mean:

- Sensor Input:** Choose the desired temperature sensor among the available options. See Table 01.
- Measuring Range:** Defines the output scale for the input sensor. Program here the measurement **Lower Range Value** and the **Upper Range Value**.
When the Lower Range Value is configured with a value higher than the Upper Range Value the voltage output swings from 10 to 0 V.
The values configured in these fields can not be beyond the sensor measuring range. The minimum span value has to be observed as well (see Table 01).
- Line Noise Rejection:** The transmitter incorporates a digital filter to cancel the induced noise from the 50 or 60 Hz systems. For better performance, select the line frequency used in your country.
- Sensor Failure Detection:** Establishes the transmitter output behavior (upscale or down-scale) in the presence of a sensor fail..
- Zero Correction:** Allows for small sensor corrections.
- Read Configuration:** Brings to the screen the Transmitter parameters configuration.
- Apply:** Sends a new configuration to the transmitter.
- Device Information:** The *Device Information* box contains relevant data concerning a particular transmitter. Please pass along this information when contacting the technical assistance department.

Note: The factory default configuration is (unless otherwise specified or ordered):

- Pt100 input, 0 to 100 °C
- 60 Hz filtering and upscale (20 mA) output for sensor fail.

During the configuration, the transmitter requires to be powered. Depending on the PC used, the power can be supplied by the serial port. To assure proper communication, it is recommended to apply external power to the transmitter.



The TxConfig interfaces contain dedicated circuitry for proper communication between transmitters and computer. Always make use of the TxConfig interfaces for configuration purposes, otherwise the transmitters may get damaged, voiding the warranty.

It is important to follow the recommendations below

- Signal wires should be installed in grounded conduits and away from power or contactor wires.
- The instrument should have its own power supply wires, which should not be shared with electrical motors, coils, contactors, etc.
- Installing RC filters is strongly recommended at contactor coils or any other inductors
- System failure should always be taken into account when designing a control panel to avoid irreversible damage to equipment or people.