

# 2-WIRE PROGRAMMABLE TRANSMITTER



- RTD, TC, Ohm, or mV input
- Extremely high measurement accuracy
- Galvanic isolation
- Programmable sensor error value
- 1- or 2-channel version



**Application:**

- Linearised temperature measurement with Pt100...Pt1000, Ni100...Ni1000, or TC sensor.
- Conversion of linear resistance variation to a standard analogue current signal, for instance from valves or Ohmic level sensors.
- Amplification of a bipolar mV signal to a standard 4...20 mA current signal.

**Technical characteristics:**

- Within a few seconds the user can program PR6331A to measure temperatures within all ranges defined by the norms.
- The RTD and resistance inputs have cable compensation for 2-, 3- and 4-wire connection.
- A limit can be programmed on the output signal.
- Continuous check of vital stored data for safety reasons.

**Mounting / installation:**

- Mounted vertically or horizontally on a DIN rail. Using the 2-channel version, up to 84 channels can be mounted per metre.

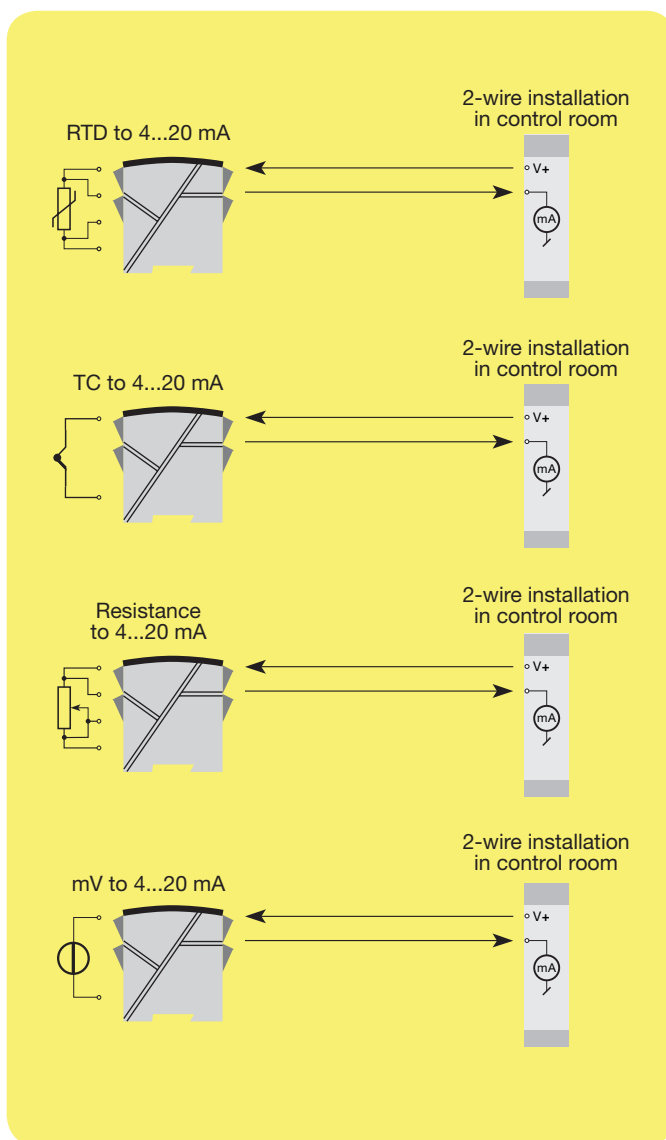

Order: 6331A

Type	Galvanic isolation	Channels
6331A	1500 VAC : 2	Single : A Double : B

**Connections:**

All connection options are shown in the user manual.

**\*NB!** Please remember to order CJC connectors type 5910 (channel 1) and 5913 (channel 2) for TC inputs with an internal CJC.

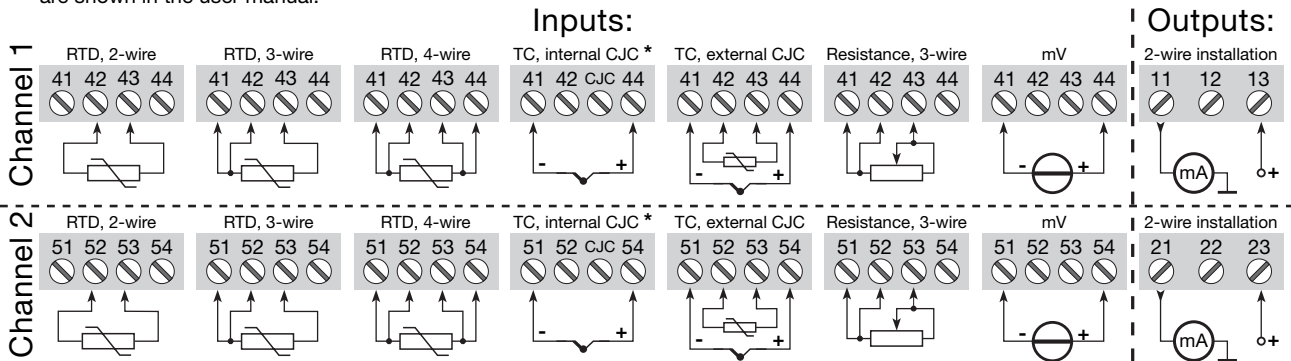

**Electrical specifications:**

**Specifications range:**  
-40°C to +60°C

**Common specifications:**

- Supply voltage, DC ..... 7.2...35 VDC
- Voltage drop ..... 7.2 VDC
- Isolation voltage, test / operation ..... 1.5 kVAC / 50 VAC
- Isolation voltage, ch. 1 / ch. 2 ..... 3.75 kVAC
- Communications interface ..... Loop Link
- Signal / noise ratio ..... Min. 60 dB
- Response time (programmable) ..... 1...60 s
- Signal dynamics, input ..... 20 bit
- Signal dynamics, output ..... 16 bit
- Calibration temperature ..... 20...28°C
- Accuracy, the greater of general and basic values:

General values		
Input type	Absolute accuracy	Temperature coefficient
All	≤ ±0.05% of span	≤ ±0.01% of span / °C

Basic values		
Input type	Basic accuracy	Temperature coefficient
RTD	≤ ±0.2°C	≤ ±0.01°C/°C
Lin. R	≤ ±0.1 Ω	≤ ±10 mΩ/°C
Volt	≤ ±10 μV	≤ ±1 μV/°C
TC type: E, J, K, L, N, T, U	≤ ±1°C	≤ ±0.05°C/°C
TC type: B, R, S, W3, W5, LR	≤ ±2°C	≤ ±0.2°C/°C

EMC immunity influence	< ±0.5% of span
Extended EMC immunity: NAMUR NE 21, A criterion, burst	< ±1% of span

- Humidity ..... < 95% RH (non-cond.)
- Dimensions (H x W x D) ..... 109 x 23.5 x 104 mm
- Protection degree ..... IP20

**Electrical specifications, input:**

Max. offset ..... 50% of selec. max. value

**RTD and linear resistance input:**

RTD type	Min. value	Max. value	Min. span	Standard
Pt100	-200°C	+850°C	25°C	IEC 60751
Ni100	-60°C	+250°C	25°C	DIN 43760
Lin. R	0 Ω	5000 Ω	30 Ω	-----

Cable resistance per wire (max.) ..... 5 Ω  
Sensor current ..... Nom. 0.2 mA

**TC input:**

Type	Min. temperature	Max. temperature	Min. span	Standard
B	+400°C	+1820°C	200°C	IEC584
E	-100°C	+1000°C	50°C	IEC584
J	-100°C	+1200°C	50°C	IEC584
K	-180°C	+1372°C	50°C	IEC584
L	-100°C	+900°C	50°C	DIN 43710
N	-180°C	+1300°C	100°C	IEC584
R	-50°C	+1760°C	200°C	IEC584
S	-50°C	+1760°C	200°C	IEC584
T	-200°C	+400°C	50°C	IEC584
U	-200°C	+600°C	75°C	DIN 43710
W3	0°C	+2300°C	200°C	ASTM E988-90
W5	0°C	+2300°C	200°C	ASTM E988-90
LR	-200°C	+800°C	50°C	GOST 3044-84

Cold junction compensation ..... < ±1.0°C

**Voltage input:**

Measurement range ..... -12...800 mV  
Min. span ..... 5 mV

**Current output:**

Signal range ..... 4...20 mA  
Min. signal range ..... 16 mA  
Updating time ..... 440 ms  
Load resistance ..... ≤ (V<sub>supply</sub> - 7.2) / 0.023 [Ω]

**Sensor error detection:**

Programmable ..... 3.5...23 mA  
NAMUR NE43 Upscale ..... 23 mA  
NAMUR NE43 Downscale ..... 3.5 mA

**GOST R approval:**

VNIIM, Cert. No. .... See homepage

**Observed authority requirements: Standard:**

EMC 2004/108/EC ..... EN 61326-1

**Of span** = Of the presently selected range