

# 2-WIRE PROGRAMMABLE TRANSMITTER



- RTD or Ohm input
- High measurement accuracy
- 3-wire connection
- Programmable sensor error value
- For DIN form B sensor head mounting



### Application:

- Linearised temperature measurement with Pt100...Pt1000 or Ni100...Ni1000 sensor.
- Conversion of linear resistance variation to a standard analogue current signal, for instance from valves or Ohmic level sensors.

### Technical characteristics:

- Within a few seconds the user can program PR5333D to measure temperatures within all RTD ranges defined by the norms.
- The RTD and resistance inputs have cable compensation for 3-wire connection.

### Mounting / installation:

- For DIN form B sensor head mounting.
- **NB:** As Ex barrier we recommend 5104B, 5114B, or 5116B.

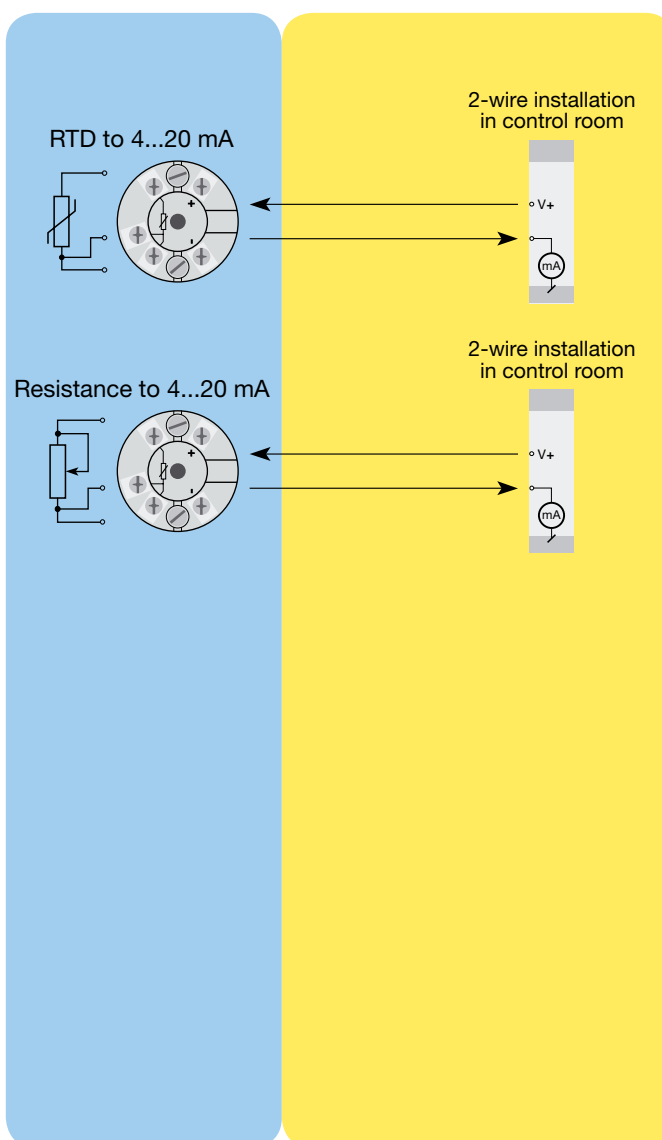

Type	Version
5333	CSA, FM & ATEX : D

**Connections:**

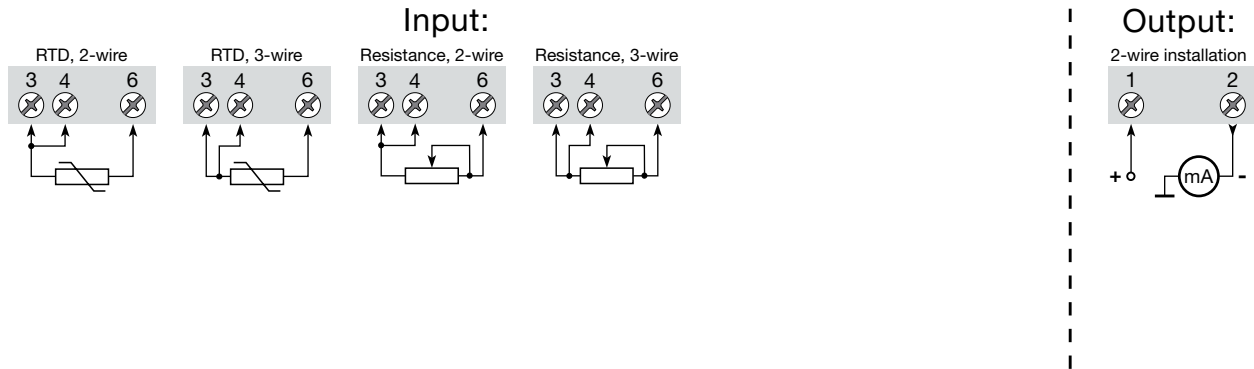

**Electrical specifications:**

**Specifications range:**

-40°C to +85°C

**Common specifications:**

- Supply voltage..... 8.0...30 VDC
- Internal consumption..... 25 mW...0.8 W
- Voltage drop ..... 8 VDC
- Warm-up time..... 5 min.
- Communications interface ..... Loop Link
- Signal / noise ratio..... Min. 60 dB
- Response time (programmable) ..... 0.33...60 s
- Signal dynamics, input ..... 19 bit
- Signal dynamics, output..... 16 bit
- Calibration temperature..... 20...28°C
- Accuracy, the greater of general and basic values:

General values		
Input type	Absolute accuracy	Temperature coefficient
All	≤ ±0.1% of span	≤ ±0.01% of span / °C

Basic values		
Input type	Basic accuracy	Temperature coefficient
RTD	≤ ±0.3°C	≤ ±0.01°C/°C
Lin. R	≤ ±0.2 Ω	≤ ±20 mΩ / °C

- EMC immunity influence ..... < ±0.5% of span
- Effect of supply voltage variation ..... ≤ 0.005% of span / VDC
- Vibration ..... IEC 60068-2-6 Test FC
- Lloyd's specification no. 1 ..... 4 g / 2...100 Hz
- Max. wire size..... 1 x 1.5 mm<sup>2</sup> stranded wire
- Humidity ..... < 95% RH (non-cond.)
- Dimensions..... Ø 44 x 20.2 mm
- Protection degree (encl. / terminal) ... IP68 / IP00
- Weight ..... 50 g

**Electrical specifications, input:**

**RTD and linear resistance input:**

RTD type	Min. value	Max. value	Min. span	Standard
Pt100	-200°C	+850°C	25°C	IEC 60751
Ni100	-60°C	+250°C	25°C	DIN 43760
Lin. R	0 Ω	10000 Ω	30 Ω	-----

- Max. offset..... 50% of selec. max. value
- Cable resistance per wire (max.) ..... 10 Ω
- Sensor current..... > 0.2 mA, < 0.4 mA
- Effect of sensor cable resistance (3-wire)..... < 0.002 Ω / Ω
- Sensor error detection..... Yes

**Output:**

**Current output:**

- Signal range ..... 4...20 mA
- Min. signal range ..... 16 mA
- Updating time ..... 135 ms
- Load resistance ..... ≤ (V<sub>supply</sub> - 8) / 0.023 [Ω]
- Load stability ..... < ±0.01% of span/100 Ω

**Sensor error detection:**

- Programmable..... 3.5...23 mA
- Namur NE43 Upscale..... 23 mA
- Namur NE43 Downscale ..... 3.5 mA

**Ex / I.S. approval:**

- KEMA 03ATEX1535 ..... II 1 G Ex ia IIC T4 or T6 II 1 D Ex iaD

- Max. amb. temperature for T1...T4.... 85°C
- Max. amb. temperature for T5 and T6... 60°C
- ATEX, applicable in zone..... 0, 1, 2, 20, 21 or 22
- ATEX Installation Drawing No. .... 5333QA01

- FM, applicable in..... IS, Class I, Div. 1, Group A, B, C, D IS, Class I, Zone 0, AEx ia IIC
- FM Installation Drawing No..... 5300Q502

- CSA, applicable in..... IS, Class I, Div. 1, Group A, B, C, D, Ex ia IIC IS, Class I, Zone 0, AEx ia IIC
- CSA Installation Drawing No..... 5333QC03

**Marine approval:**

- Det Norske Veritas, Ships & Offshore .. Stand. for Certific. No. 2.4

**GOST R approval:**

- VNIIFTRI, Cert No..... www.preelectronics.com

**Observed authority requirements:**

- EMC 2004/108/EC ..... **Standard:** EN 61326-1
- ATEX 94/9/EC ..... EN 60079-0, -11, -26 EN 61241-0, -11
- FM ..... 3600, 3611, 3610
- CSA, CAN / CSA ..... C22.2 No. 157, E60079-11, UL 913

**Of span** = Of the presently selected range