

LAN-AD16fx

LAN Data Acquisition System



Data Acquisition via Network. Remote.

The LAN technology of the LAN-AD16fx allows for measurement applications across great distances. The number of measuring points, where the devices are installed, is basically not limited. Data transmission to a server PC is fast and reliable.

PoE. Self-Supplier.

The device can be supplied with power via network (Power over Ethernet). This reduces cabling efforts to a minimum and makes mobile measurements a lot easier.

TCP/IP. Guaranteed Reliable.

LAN-AD16fx uses the TCP/IP protocol providing for safe and complete data transmission. Besides that, transmission via internet is possible - data acquisition with absolutely new possibilities.

Cascadable. Synchronizable.

The number of DAQ systems and with it the number of available channels is only limited by the bandwidth of the network. Several devices can be synchronized with each other. If so, all measured data in distributed operation always keep time even with long-term measurements.

16 Analog IN. 2 Analog OUT.

16 analog inputs can be sampled with 16 bit resolution and 250kHz total sampling rate. The measuring range ($\pm 10V$, $\pm 5V$, $\pm 2V$, $\pm 1V$) is selected via software for each channel separately.

The two $\pm 10V$ outputs can be used for analog controls with 16 bit accuracy.

32 Digital I/O.

Digital states are recorded or set at 32 digital inputs or outputs. The direction of the two 16-bit ports is set via software.

Count and Measure: Pulses. Frequency. Position. Period.

If for the acquisition of large quantities, speed measurement, or determination of position: These are only a few applications the three 32-bit counters of the LAN-AD16fx can be used for. With the pulse time feature, precise measuring e.g. at slowly rotating shafts is possible.

Open for Everyone.

Widely supported: The data acquisition system can be used under Windows[®] XP/7/8 as well as under Mac OS X, Free BSD, and Linux. The complete software for installation and programming of the LAN-AD16fx is included for free.

NextView[®]4. Try for Free.

The DAQ system is supported by NextView[®]4, the software for data acquisition and analysis. A fully functional 30-day trial is included with delivery to directly test the functionality of the LAN-AD16fx.

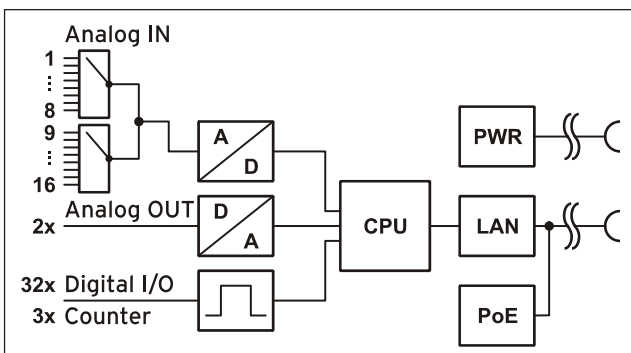

Functional diagram

► www.bmcm.de

bavarian measurement company munich

Contact Details:

Tel: +44 845 9000 601
 Fax: +44 845 9000 602
 Local Tel: 01382 443000
 Email: info@omni.uk.com

Mailing Address:

Suite E, East Kingsway Business Centre,
 Mid Craigie Trading Estate, Mid Craigie Road,
 Dundee, DD4 7RH, UK

1 Start-up Procedure



Before starting the device check the safe connection between the housing and earth (see chapter 2.2).

Connect the device to a PC or server via network (see chapter 2.1). The device is also supplied via network (PoE). Alternatively, LAN-AD16fx can be powered by an external supply unit (see chapter 2.2).

The LAN-AD16fx self-assigns a suitable link-local address when being connected.

If necessary, further software components to be used with the device can be installed now, as described in chapter 4.

2 Connections and Pin Assignment



Figure 1

2.1 Network

The PC/data acquisition server and the LAN-AD16fx communicate via LAN realized with a Twisted Pair connection (RJ45, 100Mbit). Due to automatic MDI/MDIX, using a crossover cable is not necessary. A Twisted Pair cable is available as accessory (*ZUKA-TP*).



If the two LEDs in the LAN connector are flashing, data are transmitted.



Firewall software installed on the PC might interfere with the operation of the LAN-AD16fx. In this case, please contact your network administrator.

2.2 Power Supply

The DAQ system is supplied with power via Ethernet cable (Power over Ethernet).

If the switch does not feature PoE, the device can be powered with 12-40V DC via the 3-pin DIN plug on the back of the device (see Figure 1). In this case, an external power supply unit *ZU-PW40W* (24V, 1.67A DC) is optionally available.

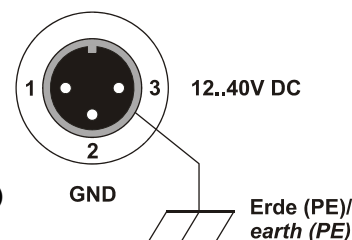

Connect the shield of the power supply with earth (PE).

2.3 Analog Channels

The 37-pin D-Sub female connector "Analog In/Out" at the back of the device is designed for the connection of the analog inputs and outputs. The input range ($\pm 10V$, $\pm 5V$, $\pm 2V$, $\pm 1V$) is set via software (e.g. in **NextView®4**), the output range is $\pm 10V$.

2.3.1 Analog Pin Assignment

The pin assignment of the 37-pin D-Sub female is as follows:

D-Sub 37	Assignment	D-Sub 37	Assignment
1	AIn 1	11	AIn 11
2	AIn 2	12	AIn 12
3	AIn 3	13	AIn 13
4	AIn 4	14	AIn 14
5	AIn 5	15	AIn 15
6	AIn 6	16	AIn 16
7	AIn 7	17	n. c.
8	AIn 8	18	AOut 1
9	AIn 9	19	AOut 2
10	AIn 10	20..37	AGND

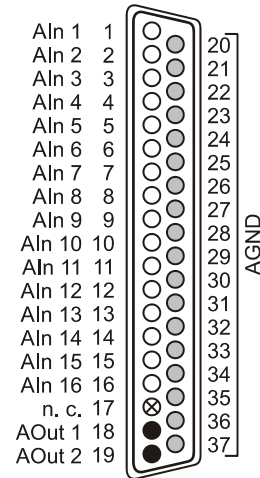

- AIn = Analogeingang / analog input
- AOut = Analogausgang / analog output
- AGND = analoge Masse / analog ground
- ⊗ n. c. = nicht verbunden / not connected



The max. potentials to ground must not exceed $\pm 12V$. Any channel overload may influence measurements of other channels and may lead to wrong values.

2.3.2 Current Measurement

The internal connection of the 16 analog inputs is provided via a 40-way pin connector (see figure on the right, here: current measurement at channel 2) on the LAN-AD16fx board, which, for example, can be used to connect current shunts (*ZU-CS250R* available as accessory).

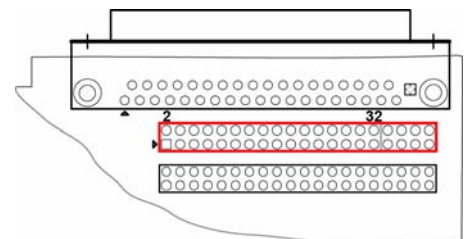

Remove all cables from the device (especially network and power supply cable) before opening the housing.

The following table shows the pin assignment of the 40-way pin connector:

Pin	Assignment	Pin	Assignment
1	AIn 1	17	AIn 9
3	AIn 2	19	AIn 10
5	AIn 3	21	AIn 11
7	AIn 4	23	AIn 12
9	AIn 5	25	AIn 13
11	AIn 6	27	AIn 14
13	AIn 7	29	AIn 15
15	AIn 8	31	AIn 16
2, 4, ..., 30, 32	AGND	33, 34, ..., 39, 40	n. c.

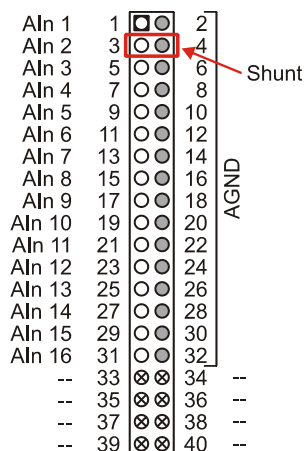

- AIn = Analogeingang / analog input
- AGND = analoge Masse / analog ground
- ⊗ -- = interne Verwendung / internal use

2.4 Digital Channels and Counters

The LAN-AD16fx features two digital ports with 16 inputs or outputs each. The lines are bidirectional and set in groups of eight. Additionally integrated are three counters (quadrature decoders) for pulse, frequency, position, or pulse time measurement.

2.4.1 Digital Assignment

All lines are led to the 37-pin D-Sub female connector at the device front. The pin assignment is as follows:

D-Sub 37 (Digital In/Out)	Assignment (Port/Bit)	D-Sub 37 (Digital In/Out)	Assignment (Port/Bit)
11	A/1	1	B/1
30	A/2	20	B/2
12	A/3	2	B/3
31	A/4	21	B/4
13	A/5	3	B/5
32	A/6	22	B/6
14	A/7	4	B/7
33	A/8	23	B/8
15	A/9	5	B/9
34	A/10	24	B/10
16	A/11	6	B/11
35	A/12	25	B/12
17	A/13	7	B/13
36	A/14	26	B/14
18	A/15	8	B/15
37	A/16	27	B/16
10, 19, 29	DGND	9, 28	5V, max. 10mA

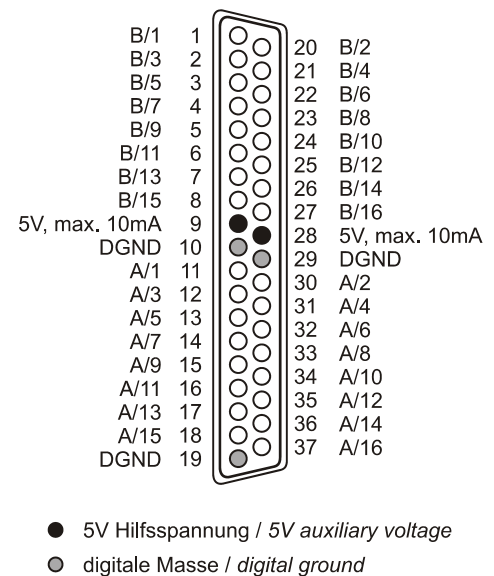

- The digital inputs and outputs are protected by serial resistors. Input voltages beyond the permitted voltage range of 0V..5V can damage the device.
- By default, port A is set to input, port B to output.
- Digital inputs are always read synchronously in time together with the analog inputs.
- Make sure the digital outputs of the device do not drive against the outputs of your signals.

2.4.2 5V Auxiliary Voltage

LAN-AD16fx provides an auxiliary voltage (e.g. for sensor supply) at pin 9, 28 of the D-Sub37 female. The 5V DC output (max. 10mA) is protected by a fuse (multifuse). In case of overload, it is sufficient to interrupt the power supply (turn off PC or disconnect the consumer load). After app. 1 min., the multifuse will be re-generated.

2.4.3 Counters with Pulse Time Measurement

The LAN-AD16fx features three 32-bit counters allowing the connection of incremental encoders. The counter inputs (A, B, and Reset) can be assigned to any digital lines of the two digital ports (configure by software).

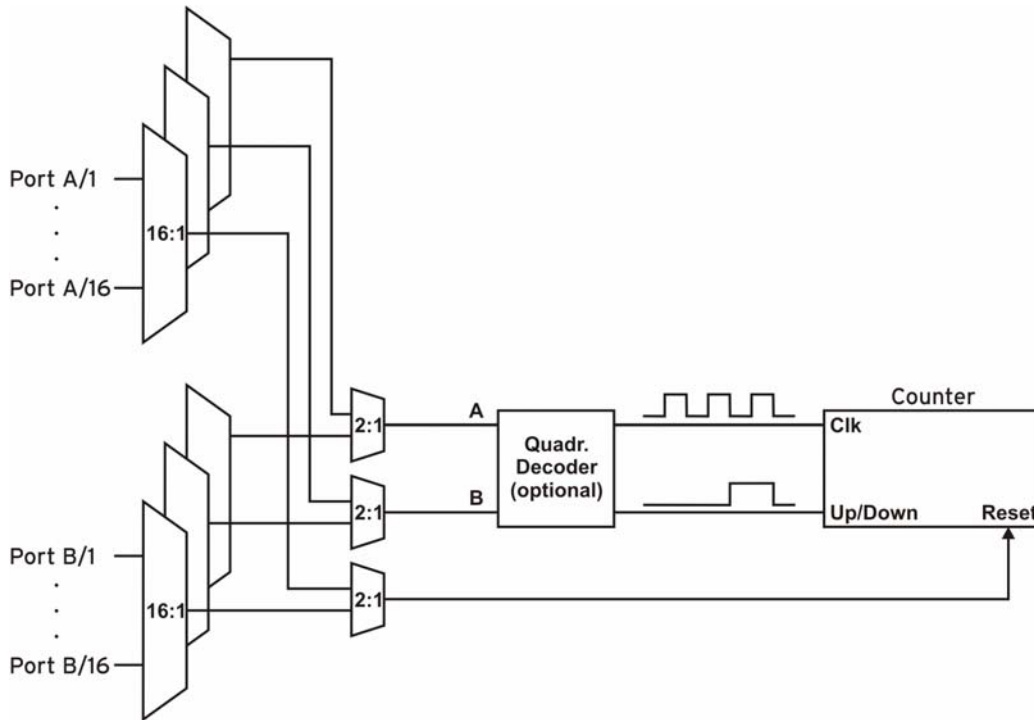

The LAN-AD16fx counts the number of incoming pulses (max. 16MHz) sampled at the connection of signal A. If the maximum counting range is reached, the counter will be reset to the minimum value of the counting range. If the external counter reset is connected, the counter can be reset at any time.

In comparison to a counter, the quadrature decoder used to connect an incremental encoder considers the counting direction by decoding a second phase-shifted signal.

To activate the counting function, the respective digital lines of the LAN-AD16fx must be assigned to the counter via software.

Function	Description	Max. Pulse Frequ.	Connection	Dig. Pins Used	Counting Range
Counter	count ↑	16MHz	Signal A	1	0..2 ³² -1
Up/Down counter	count ↑↓	16MHz	Signal A, Signal B	2	-2 ³¹ .. 2 ³¹ -1
Incremental encoder	count ↑↓	16MHz	Signal A, Signal B	2	-2 ³¹ .. 2 ³¹ -1
Pulse time measurement	measure time betw. 2 edges	16MHz	Signal A	1	-



Please refer to the relevant documentation of your product for further information about connecting your incremental encoder.

3 Interfacing Examples for Digital Channels

The following basic connection examples demonstrate the use of the digital inputs and outputs and the connection of a counter to the LAN-AD16fx. Before, however, the relating digital port must have been switched to input or output (see chapter 2.4).

3.1 Interfacing Examples for Digital Inputs

The 3.9kΩ pull-down resistor sets the input to low if no voltage is applied there.

3.1.1 Connecting an Optocoupler

Optocouplers provide optimum protection at each input line. With them, it is possible to connect higher voltages and to protect the hardware from being destroyed.

In this regard, please also see application examples of the optocoupler you use.



Optocoupler cards featuring 8 inputs are available at bmc.

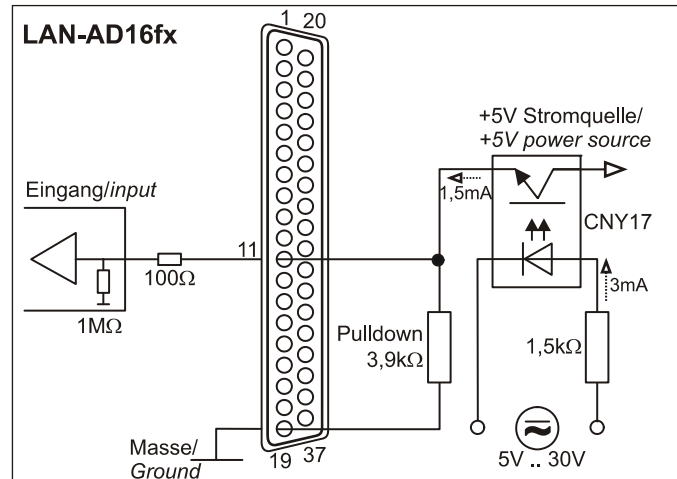

3.1.2 Connecting a Push-Button / Switch

Please make sure to use a push-button with debounce protection, because otherwise several pulses might be recorded.

The 3.9kΩ pull-down resistor is absolutely necessary to create a defined low signal!

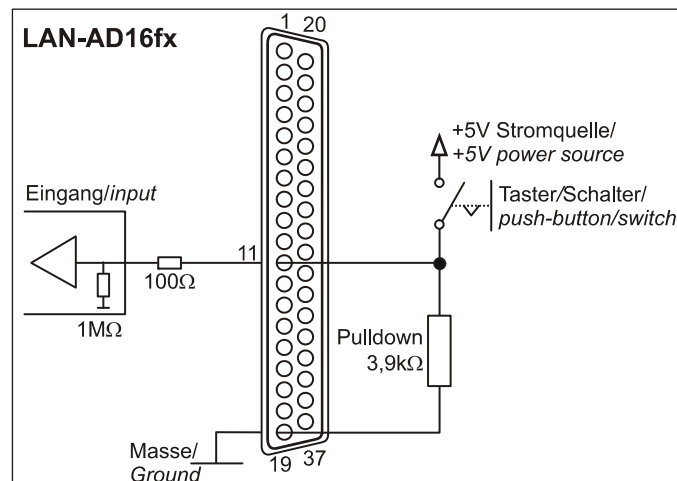

3.1.3 Connecting a Voltage Divider

If connecting a DC voltage higher than 5V, a voltage divider must be used so that 5V at the maximum are applied at the device input. Exceeding the 5V input voltage might cause damages to the device.

The relation between the two resistors to be used is calculated with the following formula:

$$U/U_1 = (R_1 + R_2)/R_1$$

Input voltages less than 5V are also sufficient (*high* ≥ 3V).

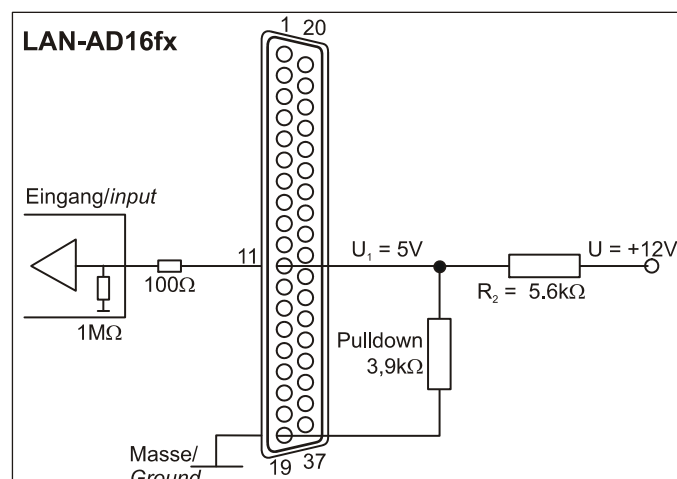

3.2 Interfacing Examples for Counters or Incremental Encoders

The connection of "Signal A", "Signal B" and "Reset" is possible at any digital line.



Make sure to configure the relating digital lines as input and to assign them to the counter.

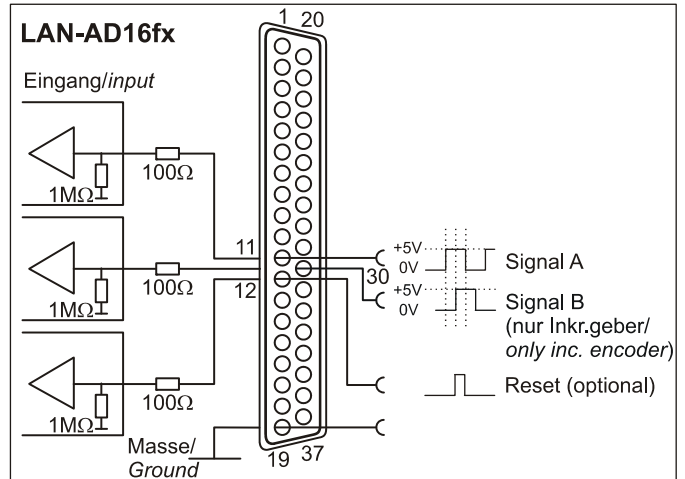

3.3 Interfacing Examples for Digital Outputs

Serial resistors in the digital lines limit the current and protect the hardware from being destroyed.

3.3.1 Connecting an LED

Only so-called low-current LEDs can be used, because they already work with 1mA current.



Please also observe the total current listed in the technical data (see chapter 8).

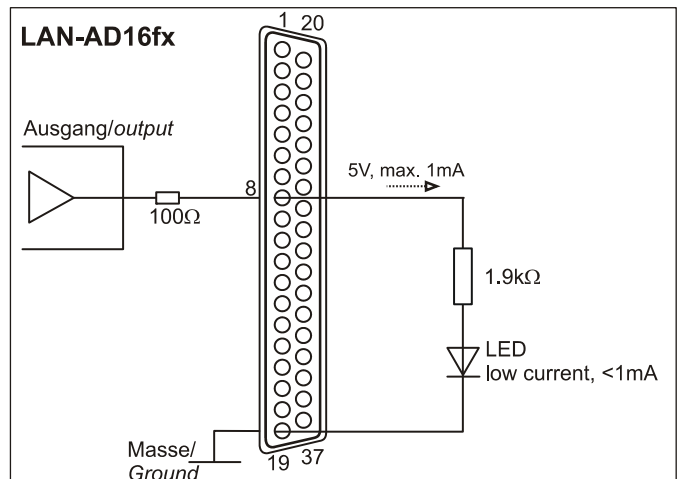

3.3.2 Connecting a Relay

A connected relay is ideal to switch higher currents. Since the field coil of the relay requires a higher current than provided by the measurement system at one line, a transistor is connected ahead.



Relay cards featuring 8 outputs are available at bmc.

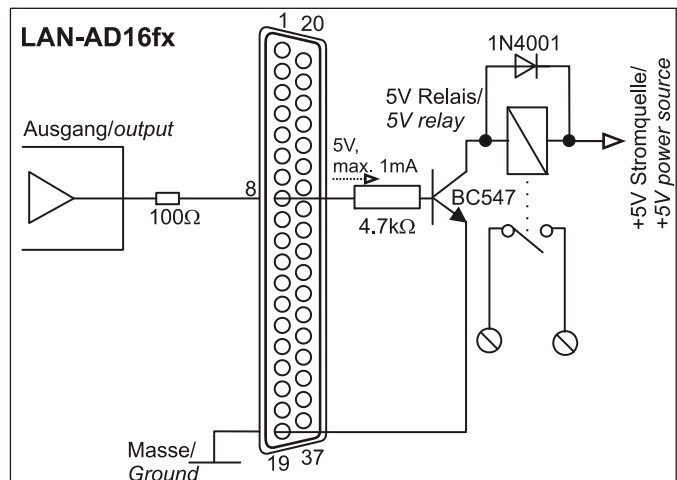

4 Software Installation and Configuration



All software and documentation available for the LAN-AD16fx are integrated on the "Software Collection" CD included with delivery. When inserting the CD, a CD starter opens automatically (otherwise: start **openhtml.exe**).



[LAN-AD16fx](#)

Change to the product page of the LAN-AD16fx by selecting the entry "Products" in the CD starter and then the hardware ("LAN-AD16fx") listed under the interface "LAN".



For detailed information about installing or operating the software, please see the corresponding manuals. The Adobe Acrobat Reader is required to open the documentation in PDF format.



You can run the installation directly from CD. If your browser prevents this, first save the setup program to hard disc before running it separately.

Software	Software Product	Notes	Documentation
Configuration	LAN-ADMIN	free software for the configuration of bmc LAN data acquisition systems	UM-LAN-ADMIN (user manual)
Programming	STR-LIBADX	ActiveX control for hardware independent programming	IG-LIBADX (installation / programming manual)
	STR-LIBADX-EX	example programs for LIBADX ActiveX control	-
	SDK-LIBAD	SDK with example programs for C/C++ on Windows [®] , Mac OS X, FreeBSD, Linux	UM-LIBAD4 (installation / programming manual)
Operating program	NV4.6	<p>measuring software NextView[®]4 available in the Standalone versions:</p> <ul style="list-style-type: none"> Lite: "slim" version with basic functions Pro: full version with complete functional range Analysis: version for the analysis of stored measuring data <p>NextView[®]4 can be used for free as a fully functional 30-day trial version. After purchasing the software, all projects, measurement files, and settings can still be used.</p>	DS-NV4 (data sheet) UM-NV4 (user manual) "First steps" in the NextView [®] 4 demo project (displayed when first starting the software)

4.1 Configuration with LAN-AD16fx Administration Utility



Network settings, firmware version and connection quality of the LAN-AD16fx can be tested or changed with the configuration software "LAN-AD16fx Administration Utility".



The LAN-AD16fx is displayed by software as "LAN-Base". The user manual [UM-LAN-ADMIN](#) describes in detail how to use the configuration software.

4.1.1 Installation

The installation program for the configuration software LAN-AD16fx Administration Utility is included on the LAN-AD16fx product page of the "Software Collection" CD. During installation, you will be prompted to choose the desired program group, to open the LAN-AD16fx Administration Utility via the Windows[®] Start menu, and the directory path, in which the software is to be installed.

If using default settings, the entry "LAN-AD16fx Administration Utility" will be available under "Programs" in the Windows[®] Start menu after installation.

4.1.2 Operation

In the left window of the program screen, all DAQ systems with a working network connection to the PC are listed displaying their serial number. The LAN-AD16fx is displayed as "LAN-Base".

In the condition as supplied to the customer, the device automatically self-assigns an IP address.

Select a network DAQ system to show the parameters of this device in the TABs on the right.

Settings can be modified by clicking the "Options" button.

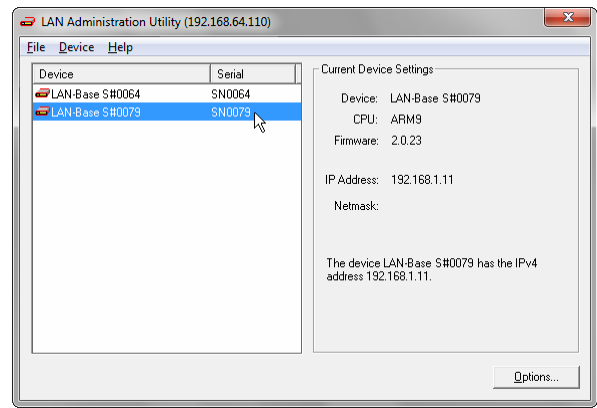

We strongly recommend using the automatically assigned configuration. Manual changes should only be done by a network administrator.

4.1.3 Notes about TCP/IP

Each participant of the network has his own IP address consisting of four groups of numbers. To guarantee that a data package arrives at the correct address, this IP address must have been given out only once.

Each IP address contains the network number identifying the net your PC belongs to. Please make sure the PC and the LAN-AD16fx are in the same net, i.e. they have the same network number, to be able to communicate with each other.

4.1.4 Example Configuration for the Manual Input of the Network Settings

If there is only the PC and the DAQ system in your network (network number **192.168.32.0**), you can use the following configuration. The IP address currently set in the PC is shown in the title bar of the LAN-AD16fx Administration Utility:

Configuration	Value
IP address PC (see chapter 4.1.5)	192.168.32.1
IP address LAN-AD16fx	192.168.32.2
network mask	255.255.255.0

4.1.5 Assign IP Address to the PC



The IP address of the PC and the netmask is entered via the Control Panel of the PC in the dialog "Internet Protocol (TCP/IP) Properties". Step by step click the following entries:

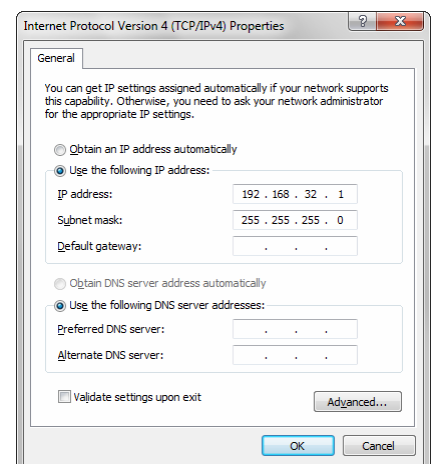

Windows® 7	Windows® 8	Windows® XP
<ul style="list-style-type: none"> ✓ Start ✓ Control Panel ✓ Network and Internet ✓ Network and Sharing Center ✓ Connections: Local Area Connection ✓ button "Properties" ✓ item "Internet Protocol Version 4 (TCP/IPv4)" ✓ button "Properties" ✓ TAB "General" 	<ul style="list-style-type: none"> ✓ right-click screen corner bottom left ✓ Control Panel ✓ Network and Internet ✓ Network and Sharing Center ✓ Connections: Ethernet ✓ button "Properties" ✓ item "Internet Protocol Version 4 (TCP/IPv4)" ✓ button "Properties" ✓ TAB "General" 	<ul style="list-style-type: none"> ✓ Start ✓ Control Panel ✓ dialog "Network Connections" ✓ Local Area Connection ✓ button "Properties" (in TAB "General") ✓ item "Internet Protocol (TCP/IP)" (in TAB "General") ✓ button "Properties" ✓ TAB "General"

4.2 Programming

Programming the LAN-AD16fx with Visual Basic®, Delphi®, Visual C++™ under Windows® XP/7/8 is possible with the hardware independent [STR-LIBADX](#). It is available on the LAN-AD16fx product page of the "Software Collection" CD. After installation, the ActiveX control must be loaded into the respective programming environment.



- **Visual Basic®**: menu "Project / Components", entry "LIBADX Object Library 4.0"

- **Delphi®**: menu "Components / Import ActiveX", entry "LIBADX Object Library 4.0"

If you select the entry [STR-LIBADX-EX](#) listed directly under the installation program of the corresponding ActiveX control, you can install example programs (with source code) demonstrating how to apply the ActiveX control.



Programming the LAN-AD16fx under Mac OS X and Unix (FreeBSD, Linux) with C/C++ is done by means of the LIBAD4 programming interface.



The [SDK-LIBAD](#) for the respective operating system (also Windows®) is included on the product page of the LAN-AD16fx. For further information about how to integrate the SDK in the programming environment, please see the corresponding programming manual [UM-LIBAD4](#).

4.3 Using LAN-AD16fx with NextView®4

Install the fully functional trial of the professional software NextView®4 for measurement data acquisition and processing to directly test the features and functions of the LAN-AD16fx.



The setup program [NV4.6](#) is available on the product page of the card. When first starting the software, request a license number with the option "Request 30 days free trial version" being checked and select your DAQ system (LAN-Base) in the following dialog "Device Setup".

The data sheet and the start project of NextView®4 contain first instructions about how to install and operate the program. For detailed information, an online help is provided.



The trial is valid for 30 days after requesting the license number. If a license is not purchased within this period, the functional range of NextView®4 will be considerably cut down!

5 Synchronization

In NextView®4 (see chapter 6), LAN-AD16fx devices can do measurement time-synchronously in relation to real-time. The frequency of the sample clock is adjusted by means of a configured NTP server.

Settings for time-synchronous measurements are done in the LAN-AD16fx Administration Utility (see chapter 4.1) as well as in NextView®4 and are described in the user manual [UM-LAN-ADMIN](#).

6 LAN-AD16fx and NextView®4

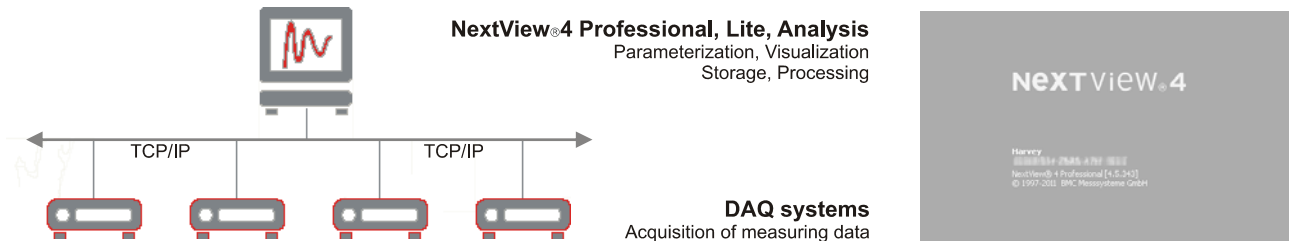

The device perfectly goes together with the modern data acquisition and analysis program NextView®4 (see chapter 4.3):

- different versions (Trial, Lite, Professional, Analysis) available (German or English)
- unlimited number of devices (even of different type) can be installed (not: NextView®4 Lite/Analysis)
- configure, scan, visualize, record, analyze, document in one software
- no programming skills required
- for further information visit : www.nextview.de/en

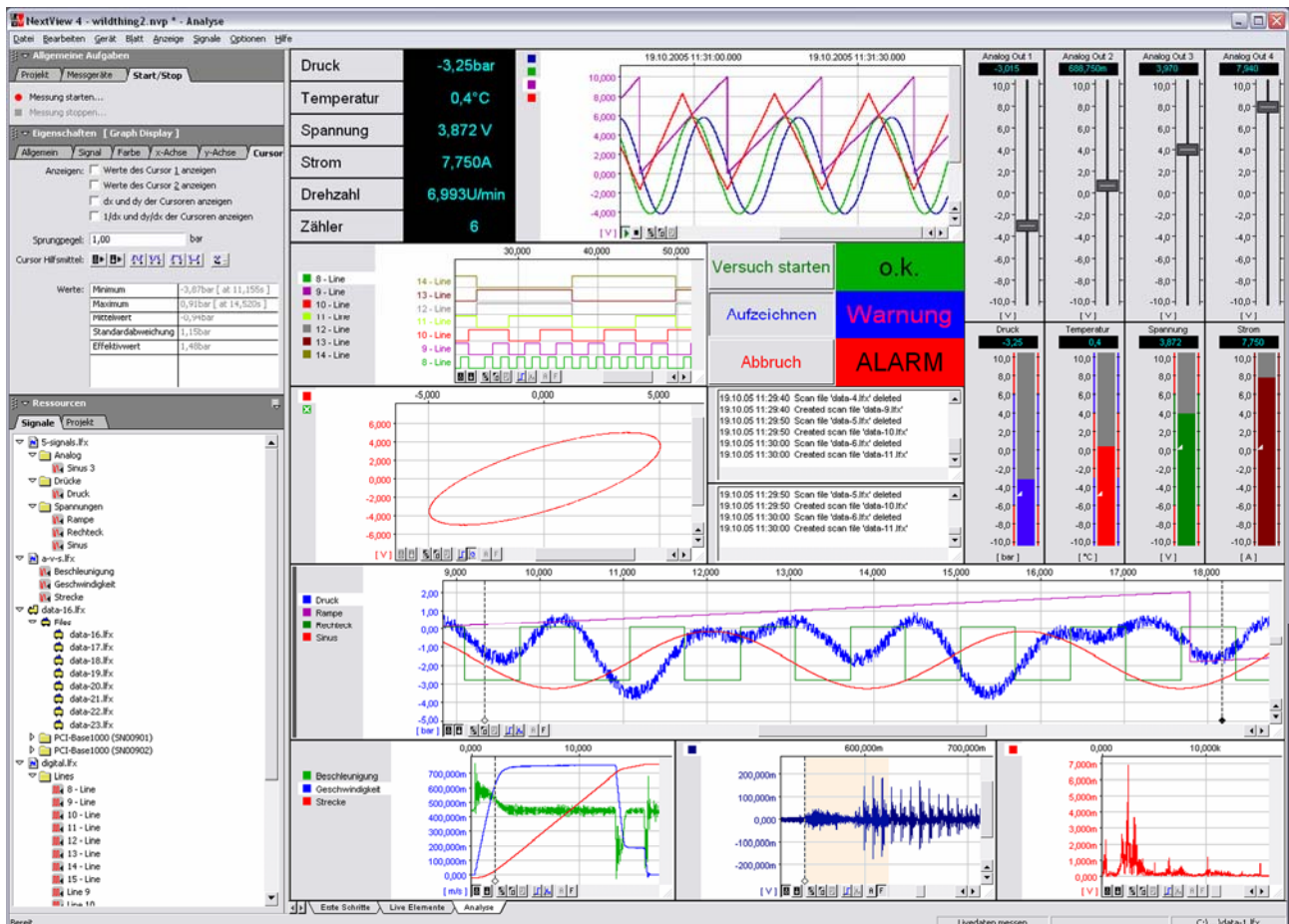

7 Important Notes for Using the LAN-AD16fx

- The device is only suitable for extra-low voltages - please observe the relevant regulations! Only use the device with housing closed. ESD voltages at open lines may cause malfunction. Only use an electrical isolated power supply unit (with CE).
- Only use non-solvent detergents for cleaning. The product is designed to be maintenance-free.
- Signal cables are connected at the two 37-pin D-Sub female connectors – preferably use shielded cables. For best possible interference suppression, connect shield at one end only. Close open inputs if necessary.
- The gain is adjusted to even values. Therefore, only 64000 values (for 16 bit) of the full range of the converter are used. As a result, the measuring ranges are slightly larger (e.g. $\pm 10.24V$) than the indicated measuring ranges so that overranges can be recognized.
- The device must not be used for safety-relevant tasks. With the use of the product, the customer becomes manufacturer by law and is therefore fully responsible for the proper installation and use of the product. In the case of improper use and/or unauthorized interference, our warranty ceases and any warranty claim is excluded.



Do not dispose of the product in the domestic waste or at any waste collection places. It has to be either duly disposed according to the WEEE directive or can be returned to bmcm at your own expense.

8 Technical Data

(typical at 20°C, after 5min., +12V supply)

• Analog Inputs

Channels // Resolution // Sampling rate:
Measuring ranges // Noise:
Surge protection:
Memory depth:
Input resistance // Input capacity:
Zero shift // Gain drop:
Frequency accuracy // Frequency drift:

16 analog inputs (single-ended) // 16 Bit // max. 250kHz total sampling rate*			
$\pm 10V // \pm 5$ LSB	$\pm 5V // \pm 7$ LSB	$\pm 2V // \pm 8$ LSB	$\pm 1V // \pm 8$ LSB
$\pm 35V$ (when turned on), $\pm 20V$ (when turned off), max. $\pm 20mA$ in total of all input channels!			
only depending on the size of the hard disk of the server PC			
1M Ω (with device turned off: 1k Ω) // 5pF			
$\pm 50ppm/^\circ C // \pm 50ppm/^\circ C$			
max. $\pm 100ppm // \max. \pm 50ppm/^\circ C$			

* The total sampling rate is the sum of the sampling rates of the individual used channels (e.g. if 5 channels are scanned with 50kHz, the total sampling rate adds up to 250kHz).

The values for accuracy always relate to the respective measuring range. Errors might add at worst.

• Analog Outputs

Output range // Output current:
Resolution // Accuracy:
Zero shift // Gain drop:

2 voltage outputs with $\pm 10V // 1mA$ max.
16 bit // typ. 1mV
$\pm 50ppm/^\circ C // \pm 50ppm/^\circ C$

• Digital Channels

Channels:
Counters:
Level:
Resistance R_i // Output current:

2x 16 lines (bidirectional, set in groups of 8)
3x 32-bit counters with opt. counter reset, operating mode: counter, up/down counter, quadrature decoder for incremental encoder, pulsetime measurement (set by software), connect at any digital inputs
CMOS/TTL compatible (low: 0V..0.7V; high: 3V..5V)
100 $\Omega // 0.5mA$

• General Data

Power supply:
Connections analog // digital:
LAN connection:
CE standards:
ElektroG // ear registration:
Max. permissible potentials:
Temperature ranges // Relative humidity:
Dimensions // Protection type:
Delivery:
Available accessories (optional):
Warranty:

via network (Power over Ethernet) with switch featuring PoE; otherwise externally: +12..40V DC, typ. 3W, max. 5W (electr. isolated by DC/DC converter in the device) at 3-pin DIN plug
all channels at a 37-pin D-Sub female at the device back // front
Twisted Pair RJ45 socket, 100Mbit, , automatic MDI/MDI-x detection
EN61000-6-1, EN61000-6-3, EN61010-1; for decl. of conformity (PDF)
RoHS and WEEE compliant // WEEE Reg.-No. DE75472248
60V DC acc. to VDE , max. 1kV ESD on open lines
operating temp. -25..50°C, storage temp. -25..70°C // 0-90% (not condensing)
167 x 113 x 30 mm ³ // IP30
device in aluminum housing, 3-pin DIN connector, "Software Collection" CD, description
power supply unit ZU-PW40W, current shunt ZU-CS250R, gender changer ZU37SS, connecting cables ZUKA37SB, ZUKA37SS, ZUKA-TP (Twisted Pair), D-Sub plug ZUST37, 3-pin DIN socket ZU3DIN, connector boards ZU37BB/-CB/-CO, DIN rail set ZU-SCHI, waterproof housing ZU-PBOX-LAN
2 years from date of purchase at bmcm, claims for damages resulting from improper use excluded

• Software

Software on CD (included):
NextView®4 (optional):

ActiveX Controls LIBADX (hardware independent) for programming on Windows® XP/7/8; LIBAD4 SDK for C/C++ programming on Windows® XP/7/8, Mac OS X, Unix (FreeBSD, Linux); trial version of the measuring software NextView®4 to test and operate the hardware; configuration software LAN-Admin
professional software (versions: Professional, Lite) for the acquisition and analysis of measurement data on Windows® XP/7/8